

# Catálogo de Perfis

edição 2024



**raltex**

PERFIS DE ALUMÍNIO



CÓDIGO	PESO KG/M	PÁGINA
29022	0,264	97
29160	1,254	68
39077	0,177	97
39137	0,138	98
39143	0,143	99
39498	0,636	75
39811	3,433	68
50018	0,263	69
78719	1,555	71
78-1153C	0,377	8
78-1730C	1,490	13
78-1740D	1,800	77
A-055	0,483	5
A-056	0,373	5
A-058	0,203	8
A-072	1,280	85
A-096	1,822	86
A-103	1,545	14
A-104	0,870	13
A-144	0,730	9
A-207	0,582	6
AF-018	0,103	35
BG-023	0,216	14
BG-057	0,172	57
BX-104	0,100	98
CG-074	0,242	73
CG-075	0,519	73
CG-077	0,488	73
CG-083	1,321	73
CL-006	1,047	4
CL-011	0,335	4
CM-012	0,260	1
CM-060	0,220	3
CM-063	0,175	3
CM-098	0,381	3
CM-151	0,322	3
CM-169	0,361	2
CM-173	0,509	3
CM-174	0,409	3
CX-003	0,198	8
CX-185	0,841	76
CX-188	0,629	76
CX-189	1,600	76
CX-190	1,085	9
CX-191	1,930	13
D-053	1,300	75
D-055	0,510	70
D-069	1,053	72
D-078	0,720	71
D-079	0,576	71
D-080	0,524	70
D-081	0,610	70
D-082	0,342	70

CÓDIGO	PESO KG/M	PÁGINA
D-094	0,686	75
D-102	0,627	71
D-103	0,779	70
DS-238	0,500	62
E-277	0,509	6
E-364	0,393	69
FC-087	1,025	80
FC-088	0,906	80
FC-202	1,900	81
FC-222	0,759	82
FC-225	0,640	81
FC-226	0,749	82
FC-227	0,740	82
FC-228	0,600	83
FC-229	0,467	80
FC-231	1,062	81
FC-242	0,791	84
FC-243	1,033	81
FC-244	1,786	84
FC-249	0,604	82
FC-261	0,556	83
FC-293	0,651	83
L-516	0,295	2
L-519	0,300	10
L-521	0,331	14
L-715	0,275	6
LG-002	0,632	36
LG-003	0,754	36
LG-004	2,019	38
LG-005	2,104	38
LG-007	1,200	48
LG-007	0,664	48
LG-007/B	1,280	48
LG-015	0,142	57
LG-016	0,330	54
LG-017	0,995	49
LG-018	1,580	51
LG-019	1,079	47
LG-020	1,119	49
LG-021	1,782	51
LG-022	1,074	50
LG-023	0,551	52
LG-024	1,143	37
LG-026	0,150	57
LG-027	0,144	57
LG-028	0,464	46
LG-042	0,959	54
LG-043	0,933	54
LG-044	1,230	36
LG-045	0,651	45
LG-046	0,204	46
LG-047	1,165	36

CÓDIGO	PESO KG/M	PÁGINA
LG-048	0,959	47
LG-049	0,959	47
LG-050	0,787	49
LG-051	0,900	49
LG-052	1,675	52
LG-053	1,650	52
LG-054	1,575	52
LG-055	0,757	50
LG-056	0,652	54
LG-058	1,650	54
LG-059	0,174	57
LG-061	0,318	46
LG-062	1,780	39
LG-063	0,549	48
LG-064	1,282	45
LG-068	0,392	56
LG-070	2,075	41
LG-071	1,962	42
LG-072	1,098	42
LG-074	0,551	55
LG-076	0,765	55
LG-077	0,324	56
LG-079	0,753	55
LG-082	0,331	56
LG-083	0,422	56
LG-085	0,558	55
LG-091	0,135	56
LG-092	0,170	56
LG-111	0,127	46
LG-124	0,773	45
LG-157	0,251	46
LG-158	0,876	40
LG-162	1,074	47
LG-164	0,141	57
LG-176	1,542	46
LG-201	1,200	50
ME-013	0,217	2
ME-092	0,160	1
MN-001	1,314	58
MN-002	0,669	59
MN-003	1,037	61
MN-005	0,783	63
MN-006	0,878	63
MN-007	0,707	62
MN-010	1,420	61
MN-014	0,220	1
MN-015	0,790	62
MN-027	0,189	62
MN-030	1,639	58
MN-031	1,009	65
MN-032	1,286	64
MN-039	1,356	64

CÓDIGO	PESO KG/M	PÁGINA
MN-050	0,734	61
MN-055	0,382	62
MP-347	0,200	1
P-078	0,805	10
P-140	0,434	5
P-155	0,531	7
P-227A	0,295	8
P-250	1,166	14
P-258	1,187	11
P-264	1,122	9
P-268	1,362	12
P-270	0,800	9
P-273	0,552	10
P-274	0,985	7
P-279	1,079	12
P-280	0,825	12
P-318	0,653	6
P-319	0,582	7
P-412	0,570	5
P-414	0,699	6
P-574	0,634	7
PC-010	1,190	72
PU-041	0,144	97
PU-042	0,157	97
RA-200	1,968	88
RA-204	1,046	87
RA-211	0,998	88
RA-223	1,978	96
RA-228	0,588	95
RA-230	0,770	95
RA-232	0,603	95
RA-235	1,544	91
RA-236	2,364	91
RA-238A	0,572	96
RA-239A	0,582	96
RA-245	0,742	95
RA-255	0,765	94
RA-256	0,800	94
RA-258	0,590	94
RA-259	0,594	94
RA-278	1,451	92
RA-294	0,785	93
RA-347	1,330	92
RA-375	2,454	89
RA-390	3,630	90
RA-400	1,870	87
RA-515	1,470	93
RA-516	0,894	93
RAL-004	0,392	67
RAL-006/SB	0,656	53
RAL-007/SB	1,241	53
RAL-013	0,168	2



CÓDIGO	PESO KG/M	PÁGINA
RAL-021	0,176	2
RAL-021C	0,155	2
RAL-022	0,145	2
RAL-034	2,140	60
RAL-035	1,105	60
RAL-041	1,370	60
RAL-044/SB	1,750	59
RAL-045	5,195	74
RAL-046	4,624	74
RAL-049/SB	0,872	53
RAL-050/SB	0,774	53
RAL-051/SB	0,891	53
RAL-066	1,455	40
RAL-083	1,138	37
RAL-084	1,524	39
RAL-085	1,805	41
RAL-086	0,114	46
RAL-1494	2,767	44
RAL-1495	2,769	44
RAL-1496	1,583	44
RAL-286	0,265	70
RAL-306	0,404	99
RAL-306L	0,320	98
RAL-491	0,105	99
RAL-491L	0,090	98
RAL-501	1,176	71
RAL-689	0,990	78
RAL-699	0,653	79
RAL-713	0,910	99
RAL-713L	0,600	98
RAL-714	0,390	99
RAL-714L	0,260	98
RAL-780	0,296	1
RAL-782	0,951	78
RAL-858	0,746	59
RAL-977	1,035	79
RM-050	0,296	1
RM-110	0,125	2
SU-001	0,733	15
SU-002	0,691	15
SU-003	0,500	15
SU-004	0,506	16
SU-005	0,980	15
SU-006	1,086	15
SU-007	0,396	15
SU-008	0,244	16
SU-009	0,980	16
SU-010	1,021	17
SU-011	0,990	17
SU-012	0,536	17
SU-013	0,710	18
SU-014	0,587	18

CÓDIGO	PESO KG/M	PÁGINA
SU-018	0,659	19
SU-019	1,631	18
SU-039	0,575	21
SU-040	0,470	21
SU-041	0,478	21
SU-042	0,545	21
SU-047	0,998	22
SU-049	0,913	22
SU-053	0,489	24
SU-055	0,517	25
SU-056	0,560	25
SU-057	0,650	25
SU-058	0,463	21
SU-060	0,978	23
SU-061	1,060	23
SU-068	0,552	27
SU-069	0,538	27
SU-070	0,485	27
SU-071	0,285	32
SU-072	0,439	32
SU-073	0,447	32
SU-074	0,439	32
SU-079	0,352	30
SU-080	0,357	29
SU-081	0,409	29
SU-082	0,386	29
SU-083	0,733	31
SU-084	0,126	29
SU-085	0,460	30
SU-086	0,628	30
SU-088	0,312	30
SU-090	0,453	31
SU-091	0,401	31
SU-093	0,282	31
SU-094	0,371	31
SU-096	0,280	33
SU-097	0,401	33
SU-098	0,401	33
SU-099	0,230	33
SU-100	0,157	33
SU-102	0,104	35
SU-103	0,137	35
SU-107	0,271	35
SU-108	0,145	35
SU-110	0,534	34
SU-111	0,619	34
SU-120	0,401	34
SU-121	1,461	20
SU-122	1,471	20
SU-123	0,996	20
SU-186	0,467	26
SU-187	0,485	27

CÓDIGO	PESO KG/M	PÁGINA
SU-188	0,575	26
SU-190	0,502	25
SU-191	0,455	27
SU-192	0,492	21
SU-200	0,398	29
SU-202	0,733	35
SU-203	0,137	35
SU-225	1,005	24
SU-225B	0,999	24
SU-226	1,014	26
SU-227	0,348	24
SU-228	0,667	19
SU-230	0,899	19
SU-238	0,624	25
SU-239	0,734	25
SU-241	0,567	34
SU-242	0,660	28
SU-243	0,618	28
SU-245	0,597	28
SU-246	0,642	24
SU-260	0,733	19
SU-276	0,168	31
SU-279	0,522	34
SU-280	0,875	22
SU-289	1,217	23
SU-290	1,066	23
SU-291	0,263	16
SU-292	0,206	29
SU-302	0,225	16
T-214	0,200	69
U-1049	1,500	72
U-1076	0,190	14
U-1098	0,560	72
U-1108	0,360	97
U-1108D	0,500	97
U-482	0,116	10
U-495	0,171	69
U-496	0,380	69
U-497	0,570	69
U-498	0,285	69
U-522	0,100	5
U-555	0,200	97
U-555L	0,158	97
U-555G	0,333	97
U-615	0,434	85
U-621	0,265	85
U-681	0,113	8
U-877	0,350	86
U-878	0,434	86
U-990	0,650	72
US-285	0,560	67
US-294	0,260	66
VZ-006	0,560	67

CÓDIGO	PESO KG/M	PÁGINA
VZ-051	0,270	66
VZ-060	0,394	67
Y-126	0,390	5
Y-181	0,570	12
Y-335	0,792	77
Y-343	0,284	99
Z-063	0,324	69
Z-181	0,532	11
Z-201	0,275	66
Z-201V	0,260	66
Z-248	0,298	67

## Barra chata

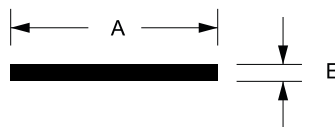

CÓDIGO	KG/METRO	MILIMETRO		POLEGADA	
		A	E	A	E
BAR-013	0,136	15,87	3,18	5/8"	1/8"
BAR-049	0,209	15,87	4,76	5/8"	3/16"
BAR-014	0,163	19,05	3,18	3/4"	1/8"
BAR-016	0,220	25,40	3,18	1"	1/8"
BAR-019	0,272	31,75	3,18	1.1/4"	1/8"
BAR-093	0,544	31,75	6,35	1.1/4"	1/4"
BC-040	0,818	31,75	9,52	1.1/4"	3/8"
BAR-022	0,324	38,10	3,18	1.1/2"	1/8"
BAR-027	0,437	50,80	3,18	2"	1/8"

## Cantoneira de abas iguais

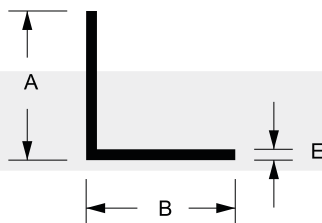

CÓDIGO	KG/METRO	MILIMETRO			POLEGADA		
		A	B	E	A	B	E
L-002	0,100	12,70	12,70	1,59	1/2"	1/2"	1/16"
L-405	0,132	15,87	15,87	1,59	5/8"	5/8"	1/16"
L-009	0,167	19,05	19,05	1,59	3/4"	3/4"	1/16"
L-013	0,210	25,40	25,40	1,59	1"	1"	1/16"
L-014	0,410	25,40	25,40	3,18	1"	1"	1/8"
L-018	0,516	31,75	31,75	3,18	1.1/4"	1.1/4"	1/8"
L-744	0,334	38,10	38,10	1,59	1.1/2"	1.1/2"	1/16"
L-022	0,673	38,10	38,10	3,18	1.1/2"	1.1/2"	1/8"
CT-217	0,516	50,80	25,40	3,00	2"	1"	-
L-612	0,567	50,80	50,80	2,00	2"	2"	-
L-025	0,840	50,80	50,80	3,18	2"	2"	1/8"
L-026	1,272	50,80	50,80	4,76	2"	2"	3/16"



**raltex**  
PERFIS DE ALUMÍNIO

# Perfis Tabelados

## Perfil U

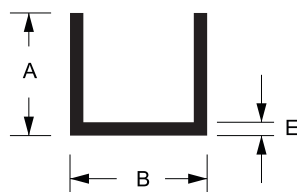

CÓDIGO	KG/METRO	MILIMETRO			POLEGADA		
		A	B	E	A	B	E
U-036	0,108	9,53	9,53	1,59	3/8"	3/8"	1/16"
PU-041	0,144	22,00	11,00	1,00	-	-	-
U-044	0,133	12,70	12,70	1,59	1/2"	1/2"	1/16"
U-306	0,266	12,70	12,70	3,18	1/2"	1/2"	1/8"
PU-042	0,157	22,00	13,80	1,00	-	-	-
U-509	0,187	15,87	15,87	1,59	5/8"	5/8"	1/16"
U-555	0,200	25,00	15,00	1,20	-	-	-
U-555G	0,333	50,00	16,00	1,40	-	-	1/16"

## Tubos Redondo

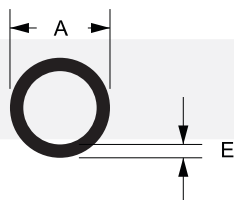

CÓDIGO	KG/METRO	MILIMETRO		POLEGADA	
		A	E	A	E
TR-002	0,100	9,53	1,58	3/8"	1/16"
TR1/2*1,00	0,100	12,70	1,00	1/2"	-
TR1/2*1,58	0,150	12,70	1,58	1/2"	1/16"
TR-014	0,182	15,88	1,58	5/8"	1/16"
TR-020	0,190	19,05	1,58	3/4"	1/16"
TR-035	0,279	22,23	1,58	7/8"	1/16"
TR-040	0,338	25,40	1,58	1"	1/16"
TR-055	0,405	31,75	1,58	1.1/4"	1/16"
TR-070	0,315	38,20	1,10	1.1/2"	-
TR-098	0,506	50,80	1,20	2"	-

## Tubo Retângular

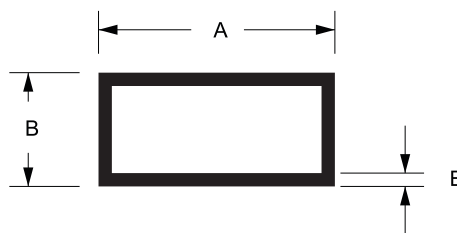

CÓDIGO	KG/METRO	MILIMETRO			POLEGADA		
		A	B	E	A	B	E
TUB-4501L	0,196	25,40	12,70	1,00	1"	1/2"	-
TUB-4509L	0,260	30,00	20,00	1,58	-	-	1/16"
TUB-4509	0,276	30,00	20,00	2,00	-	-	-
TUB-4545L	0,395	38,10	25,40	1,58	1.1/2"	1"	1/16"
TUB-4545	0,395	38,10	25,40	2,00	1.1/2"	1"	-
TUB-4536L	0,365	50,80	12,70	1,00	2"	1/2"	-
TUB-4536	0,375	50,80	12,70	1,58	2"	1/2"	1/16"
TUB-4576	0,467	50,80	25,40	1,00	2"	1"	-
TUB-4569	0,615	50,80	25,40	1,50	2"	1"	-
TUB-4513	0,700	50,80	38,10	1,58	2"	1.1/2"	1/16"
TUB-4591	0,603	76,20	25,40	1,58	3"	1"	1/16"
TUB-4517	0,846	76,20	38,10	1,40	3"	1.1/2"	-
TUB-4537	1,407	101,60	38,10	2,50	4"	1.1/2"	-
TUB-4599L	1,055	101,60	50,80	1,30	4"	2"	-
TUB-4599	1,372	101,60	50,80	1,80	4"	2"	-
TUB-4599P	2,600	101,60	50,80	2,40	4"	2"	-
TUB-4530	2,230	101,60	50,80	3,05	4"	2"	-
TUB-4520	3,152	152,40	38,10	3,20	6"	1.1/2"	-
TUB-4559L	1,622	152,40	50,80	2,00	6"	2"	-
TUB-4559	3,206	152,40	50,80	3,00	6"	2"	-

## Tubo Quadrado



CÓDIGO	KG/METRO	MILIMETRO		POLEGADA	
		A	E	A	E
TUB-4001	0,200	12,70	1,58	1/2"	1/16"
TUB-4002	0,232	15,88	1,58	5/8"	1/16"
TUB-4003	0,284	19,05	1,58	3/4"	1/16"
TUB-4003L	0,199	19,05	1,00	3/4"	-
TUB-4008L	0,273	25,40	1,00	1"	-
TUB-4008	0,400	25,40	1,58	1"	1/16"
TUB-4011	0,519	31,75	1,58	1.1/4"	1/16"
TUB-4014	0,593	38,10	1,58	1.1/2"	1/16"
TUB-4021	0,793	50,80	1,40	2"	-
TUB-4024	1,350	76,20	1,58	3"	1/16"
TUB-4054	2,251	101,60	2,50	4"	-

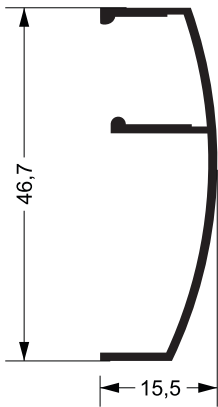

**CM-012**  
0,260 Kg/m

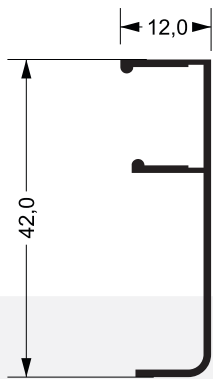

**MN-014**  
0,220 kg/m

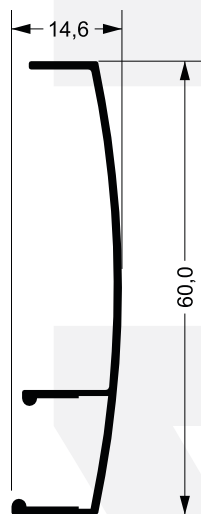

**RM-050**  
0,296 kg/m

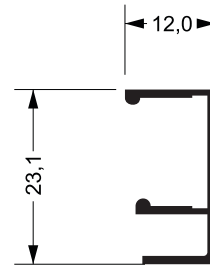

**ME-092**  
0,160 kg/m

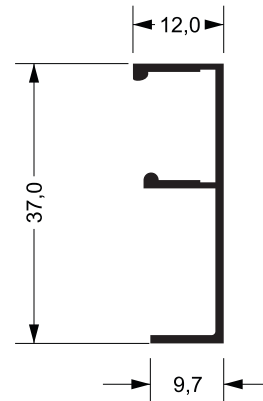

**MP-347**  
0,200 kg/m

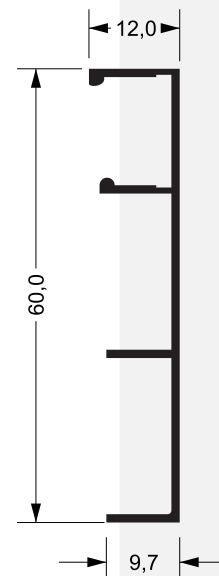

**RAL-780**  
0,296 kg/m

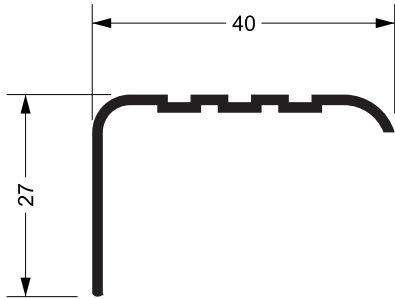

**ME-013**  
0,217 kg/m

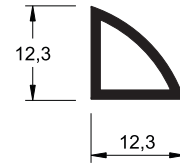

**RM-110**  
0,125 kg/m

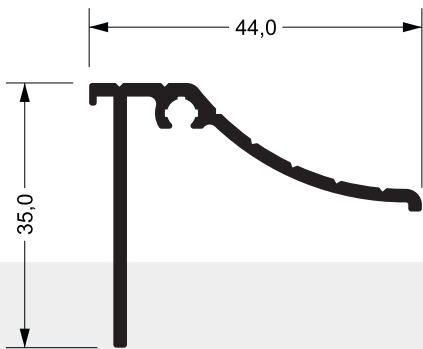

**CM-169**  
0,361 kg/m

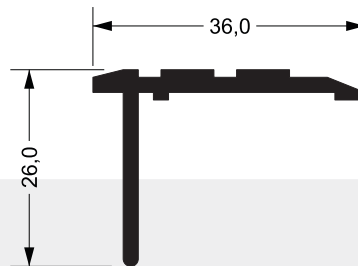

**L-516**  
0,295 kg/m

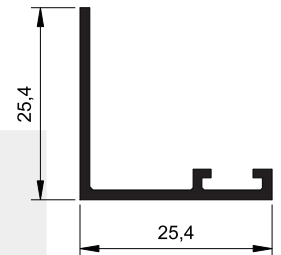

**RAL-013**  
0,168 kg/m

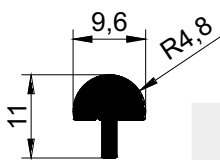

**RAL-021C**  
0,155 kg/m

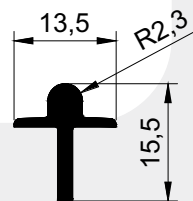

**RAL-022**  
0,145 kg/m

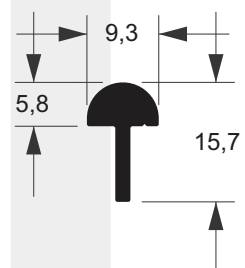

**RAL-021**  
0,176 kg/m



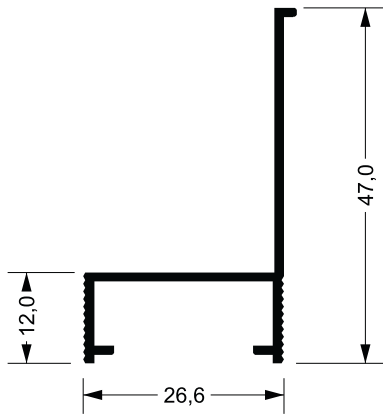

**CM-151**  
0,322 kg/m

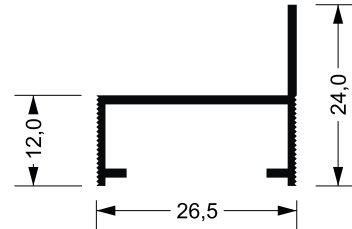

**CM-063**  
0,175 kg/m

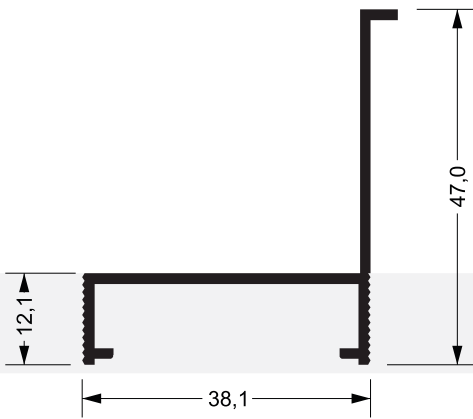

**CM-098**  
0,381 kg/m

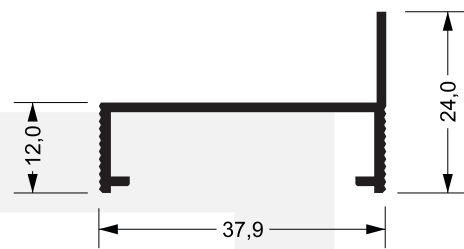

**CM-060**  
0,220 kg/m

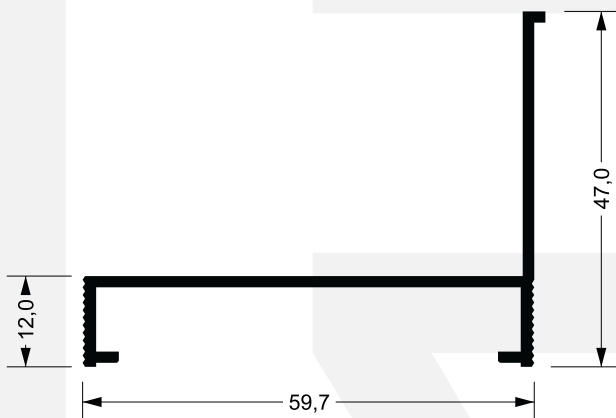

**CM-173**  
0,509 kg/m

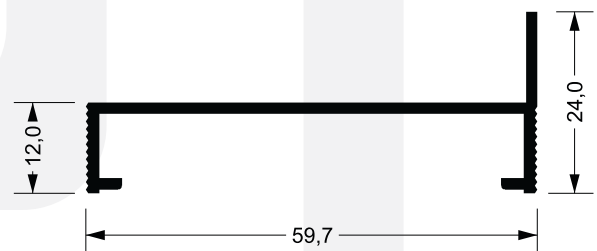

**CM-174**  
0,409 kg/m

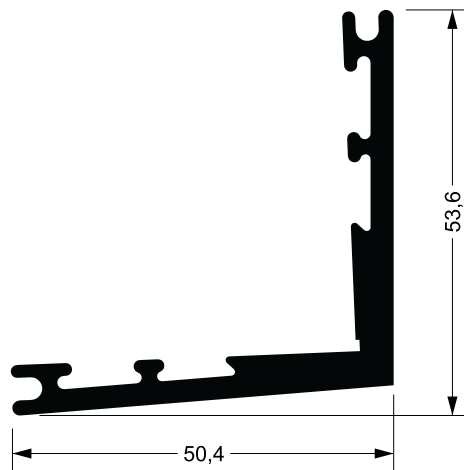

CL-006  
1,047 kg/m

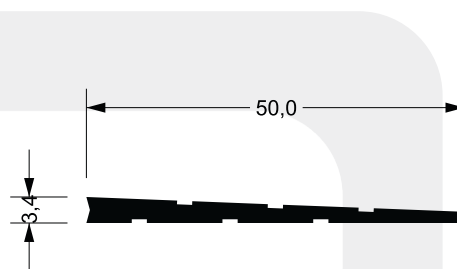

CL-011  
0,335 kg/m



**raltex**  
PERFIS DE ALUMÍNIO

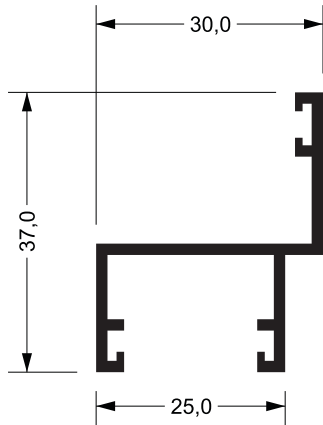

**Y-126**  
0,390 kg/m

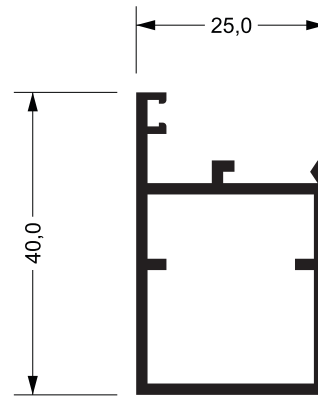

**P-140**  
0,434 kg/m

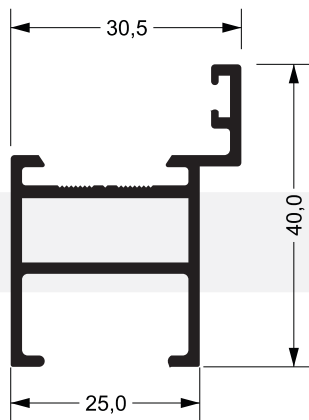

**P-412**  
0,570 kg/m

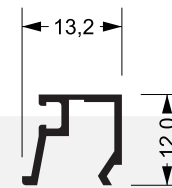

**U-522**  
0,100 kg/m

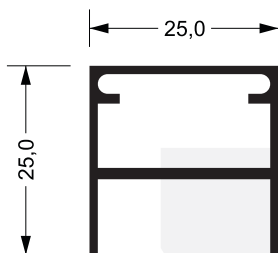

**A-056**  
0,373 kg/m

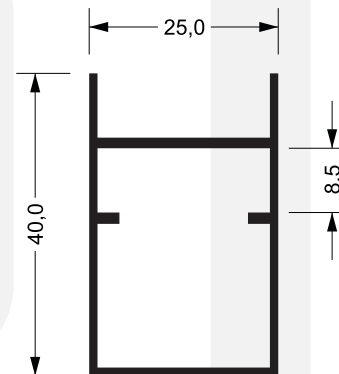

**A-055**  
0,483 kg/m

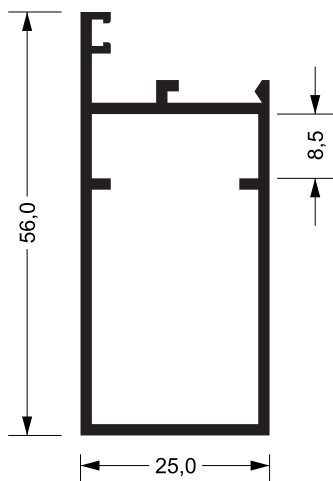

**P-318**  
0,653 kg/m

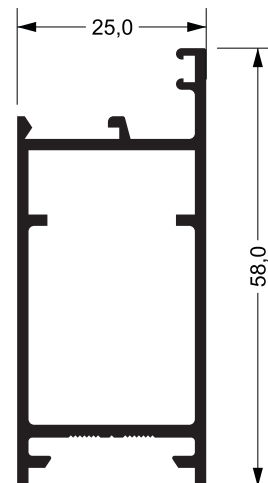

**P-414**  
0,699 kg/m

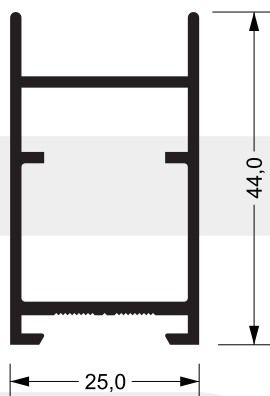

**A-207**  
0,582 kg/m

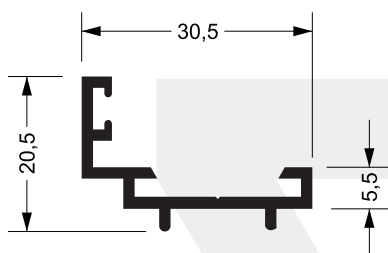

**L-715**  
0,275 kg/m



**E-277**  
0,509 kg/m

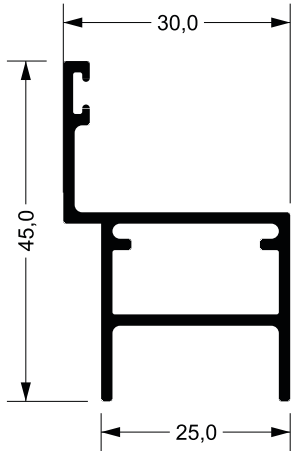

**P-155**  
0,531 kg/m

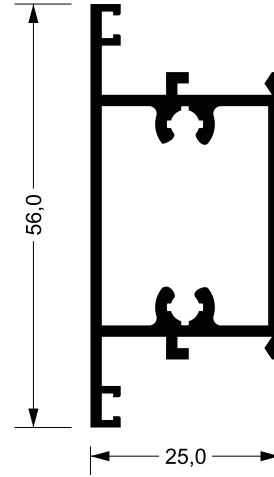

**P-319**  
0,582 kg/m

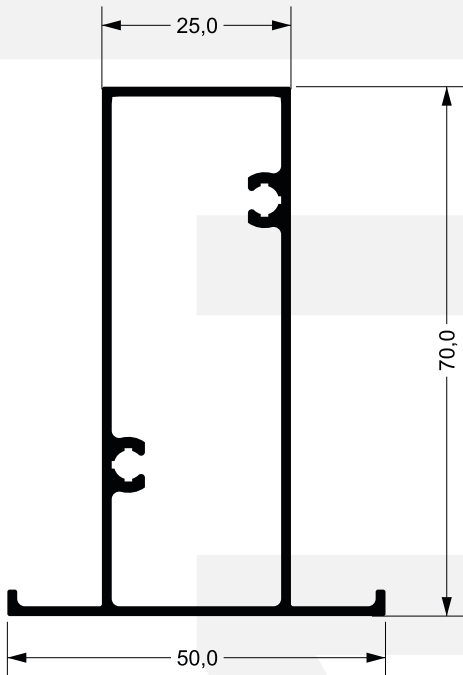

**P-274**  
0,985 kg/m

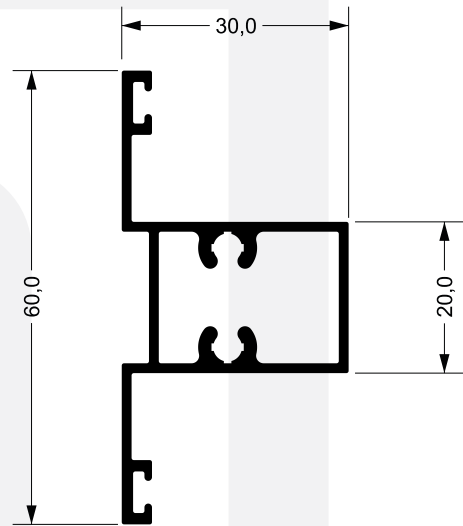

**P-574**  
0,634 kg/m

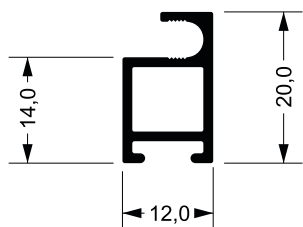

**A-058**  
0,203 kg/m

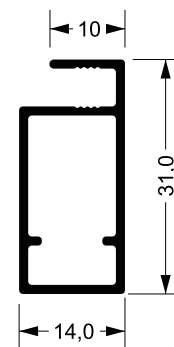

**P-227A**  
0,295 kg/m

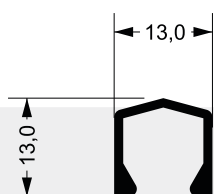

**U-681**  
0,113 kg/m

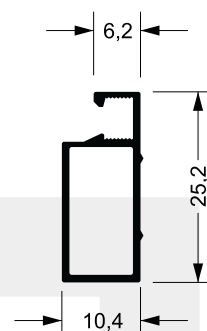

**CX-003**  
0,198 kg/m

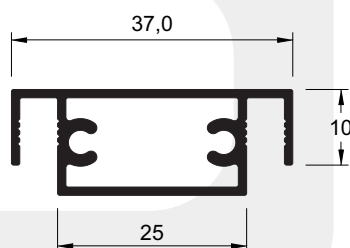

**78-1153C**  
0,377 kg/m



**raltex**  
PERFIS DE ALUMÍNIO

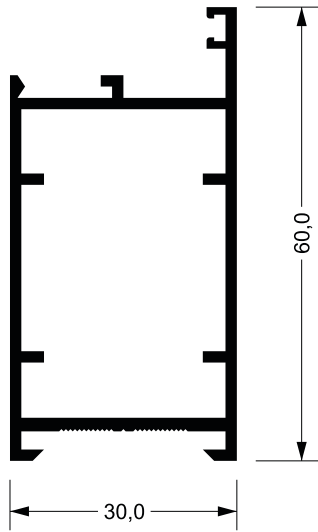

**P-270**  
0,800 kg/m

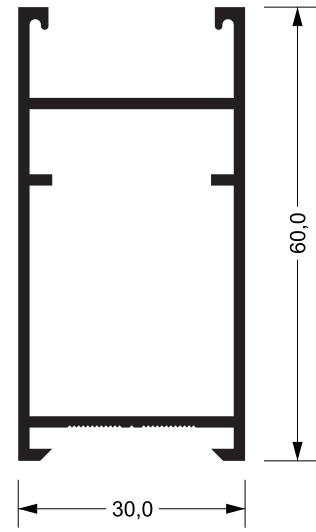

**A-144**  
0,730 kg/m

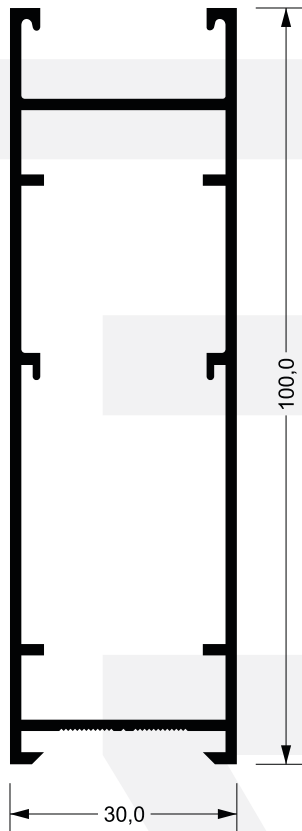

**CX-190**  
1,085 kg/m

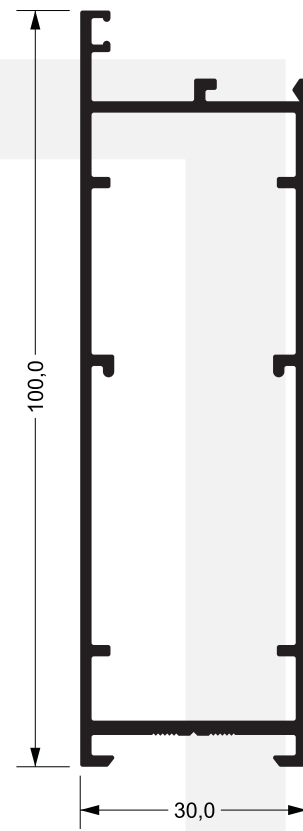

**P-264**  
1,122 kg/m

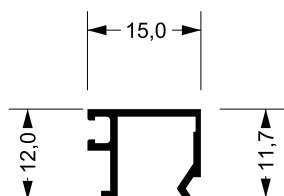

**U-482**  
0,116 kg/m

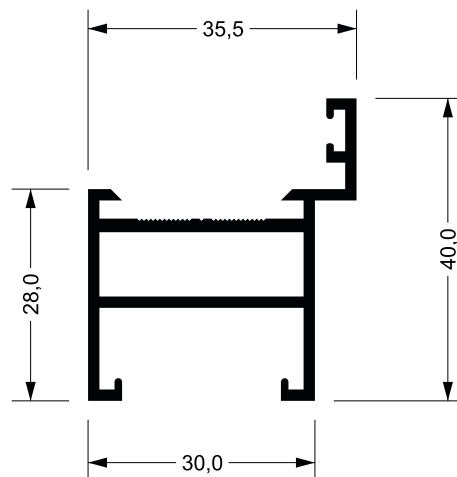

**P-273**  
0,552 kg/m

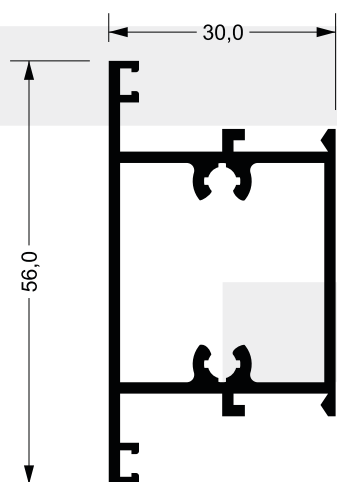

**P-078**  
0,805 kg/m

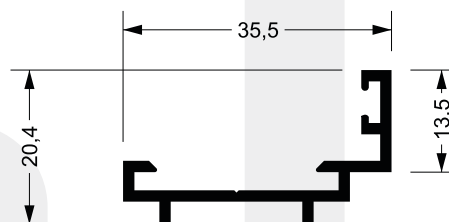

**L-519**  
0,300 kg/m



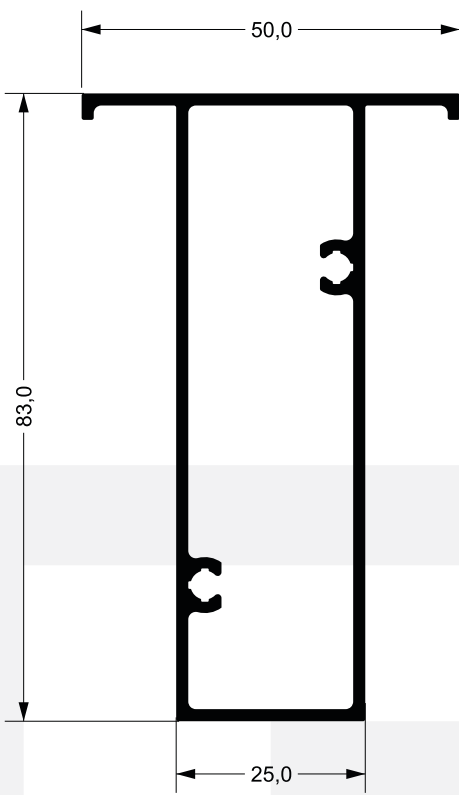

**P-258**  
1,187 kg/m

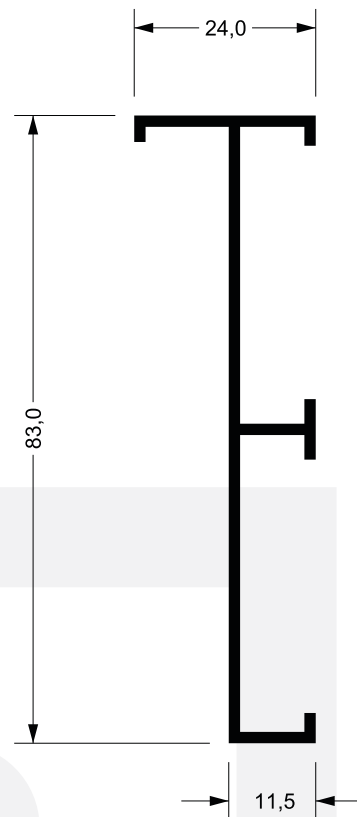

**Z-181**  
0,532 kg/m

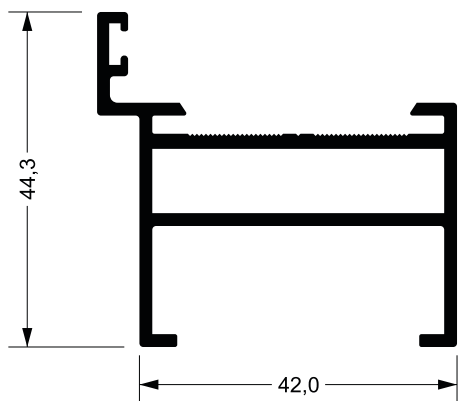

**P-280**  
0,825 kg/m

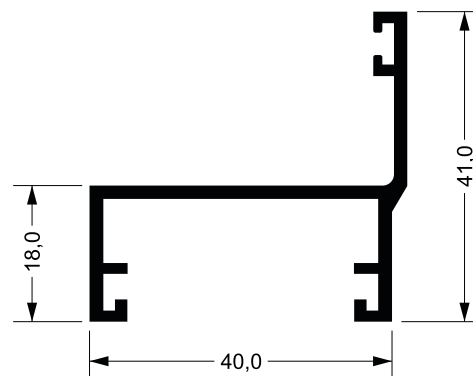

**Y-181**  
0,570 kg/m

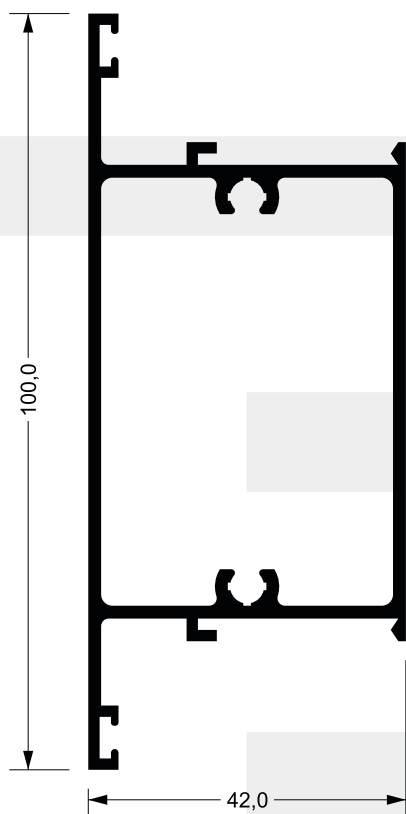

**P-279**  
1,079 kg/m

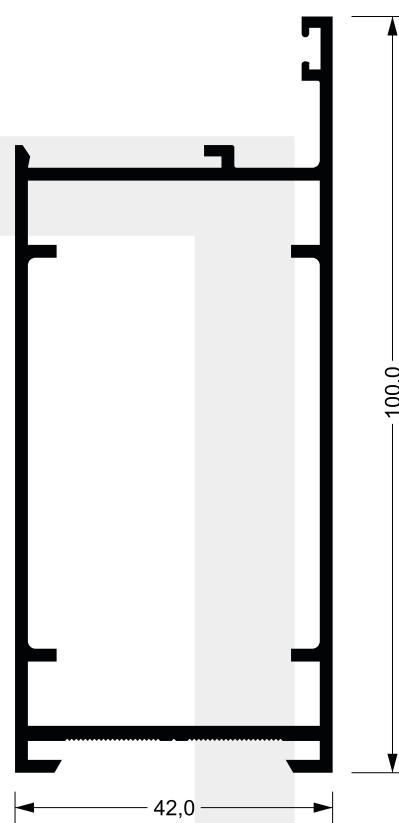

**P-268**  
1,362 kg/m



**raltext**  
PERFIS DE ALUMÍNIO

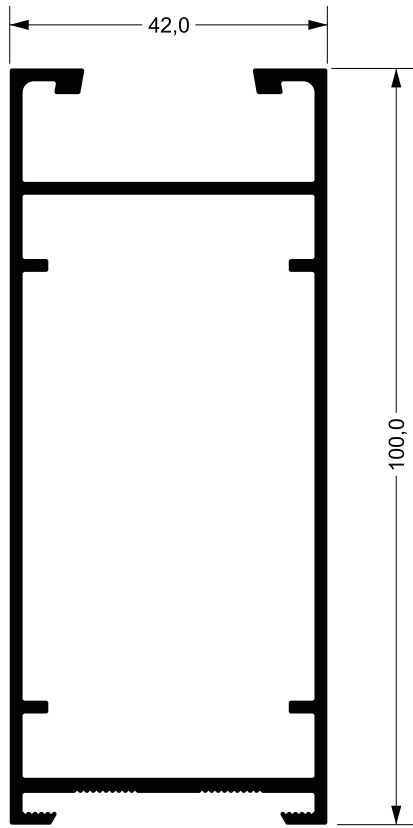

781730C  
1,490 kg/m

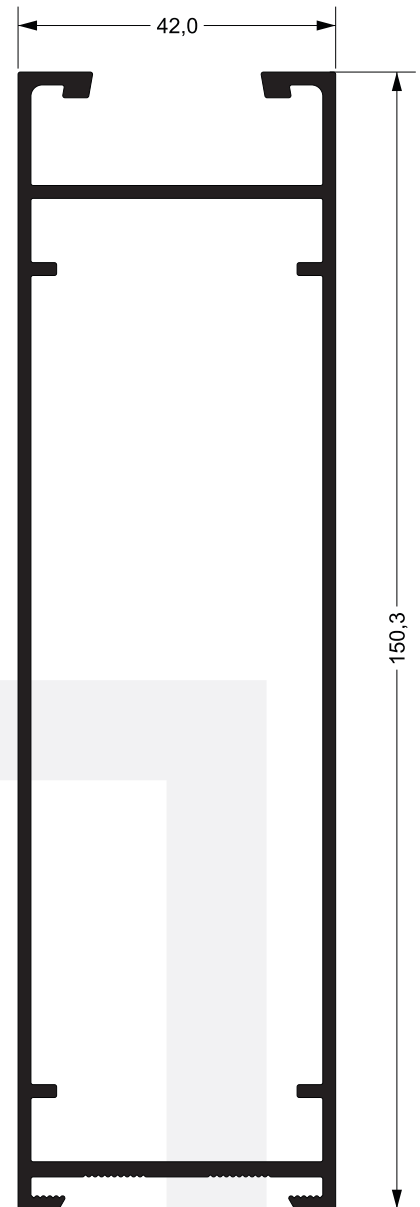

CX-191  
1,930 kg/m

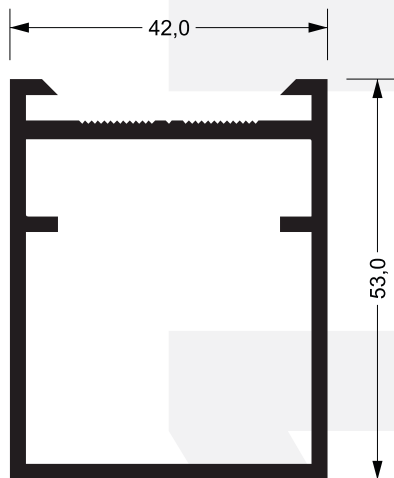

A-104  
0,870 kg/m

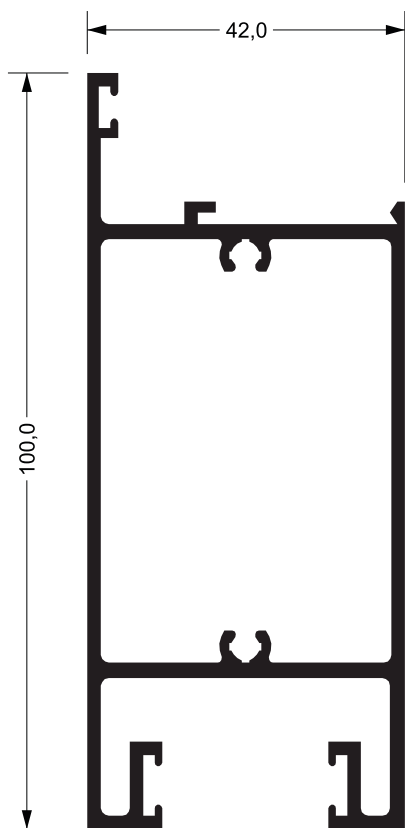

**A-103**  
1,545 kg/m

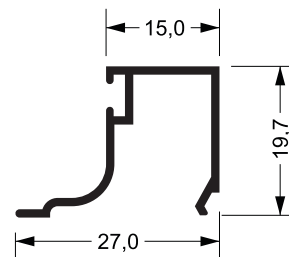

**BG-023**  
0,216 kg/m

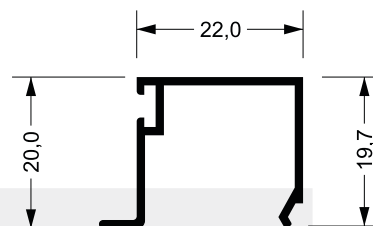

**U-1076**  
0,190 kg/m

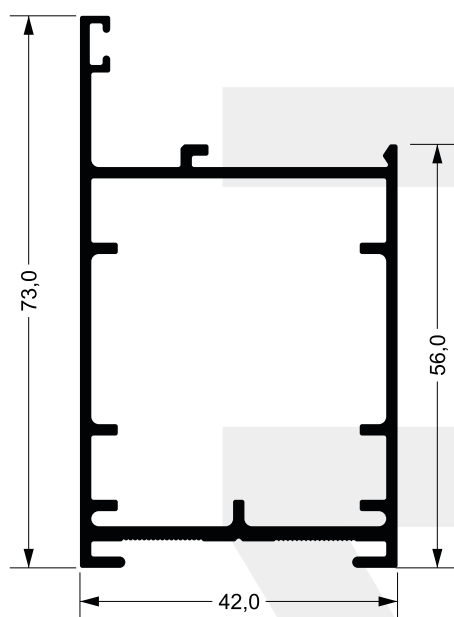

**P-250**  
1,166 kg/m

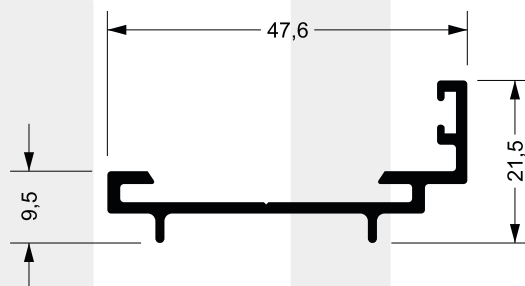

**L-521**  
0,331 kg/m



**raltext**  
PERFIS DE ALUMÍNIO

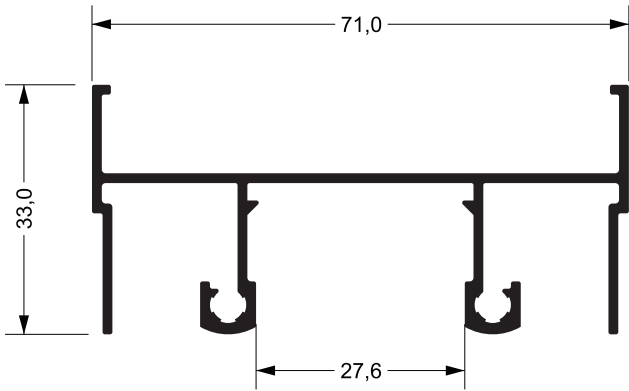

**SU-001**  
0,733 kg/m

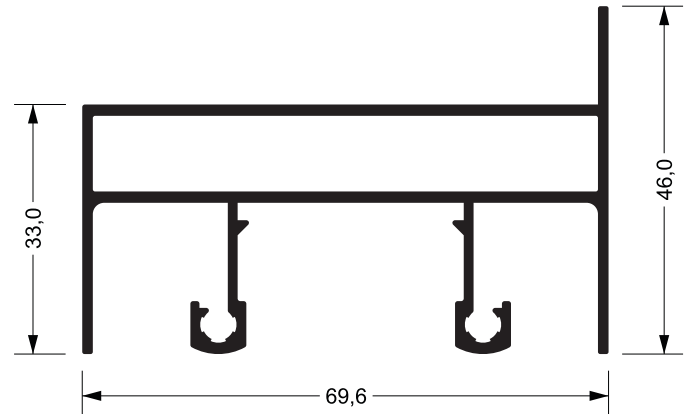

**SU-006**  
1,086 kg/m

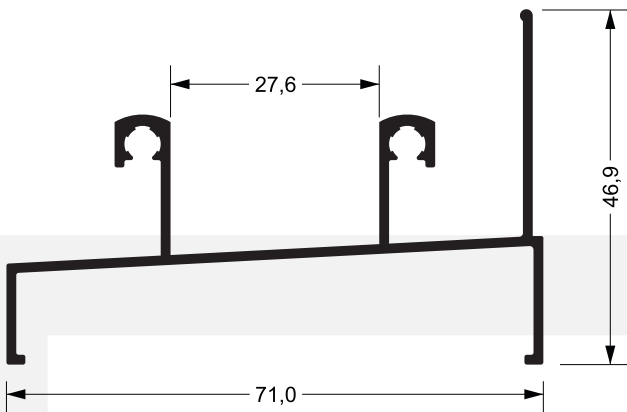

**SU-002**  
0,691 kg/m

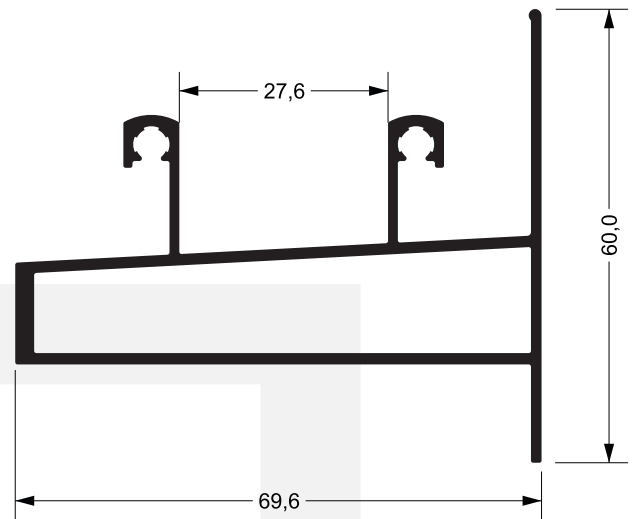

**SU-005**  
0,980 kg/m

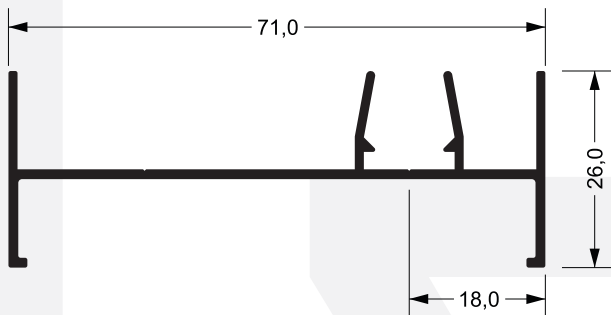

**SU-003**  
0,500 kg/m

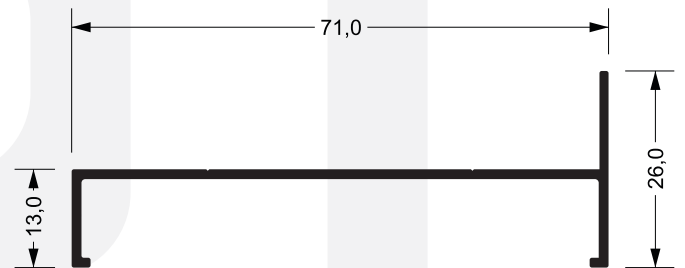

**SU-007**  
0,396 kg/m

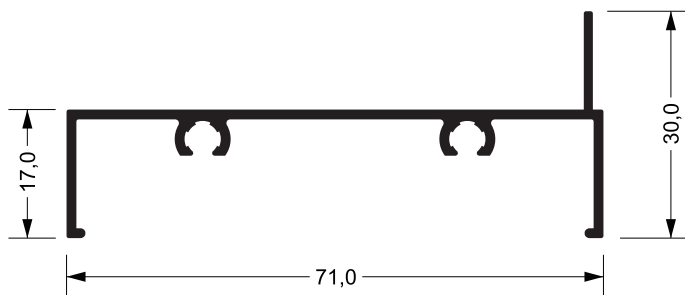

**SU-004**  
0,506 kg/m

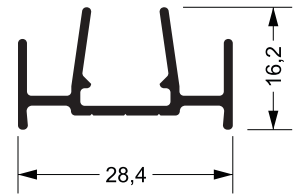

**SU-291**  
0,263 kg/m

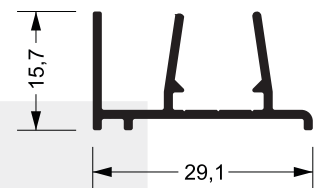

**SU-008**  
0,244 kg/m

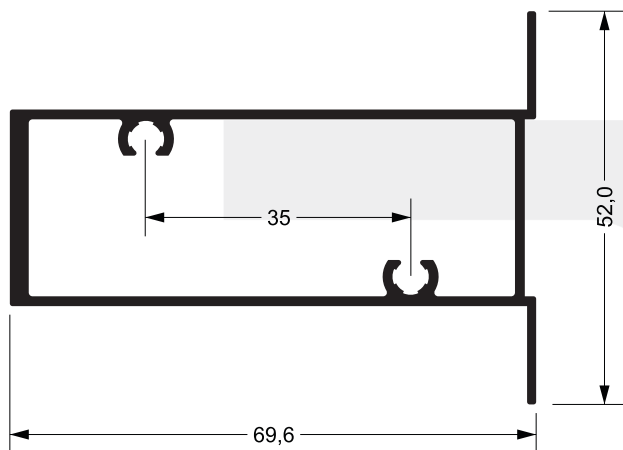

**SU-009**  
0,980 kg/m

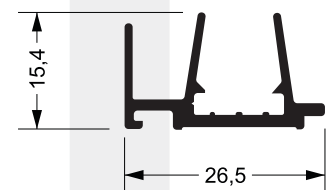

**SU-302**  
0,225 kg/m

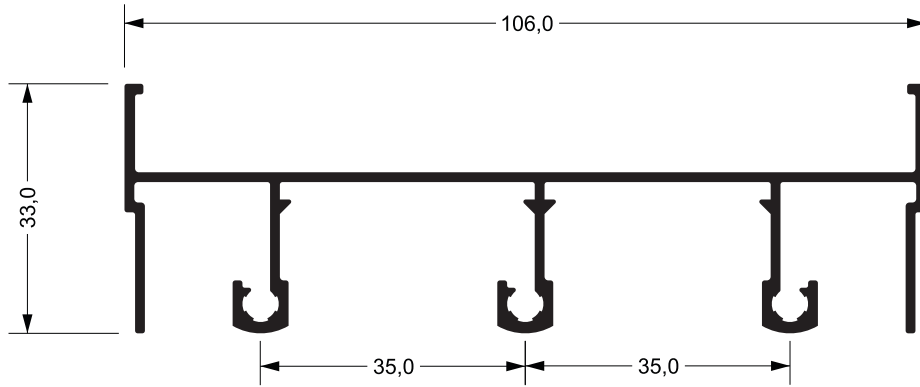

**SU-010**  
1,021 kg/m

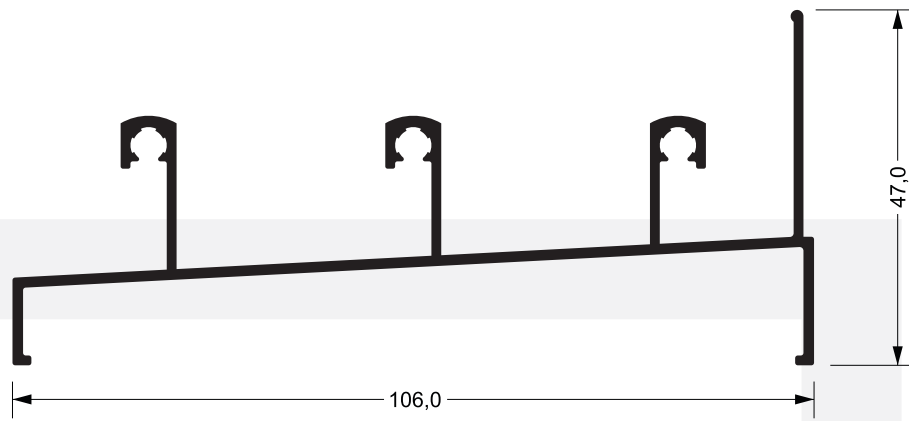

**SU-011**  
0,990 kg/m

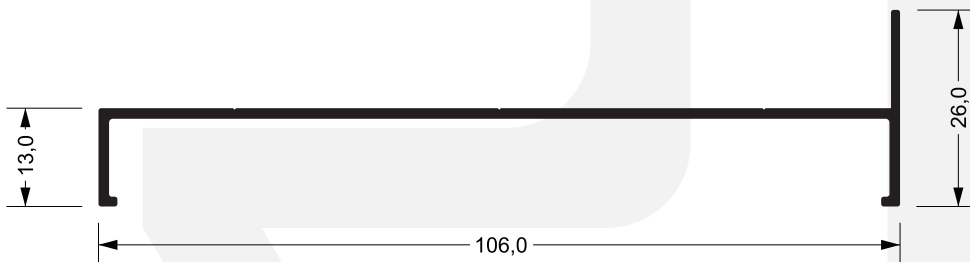

**SU-012**  
0,536 kg/m

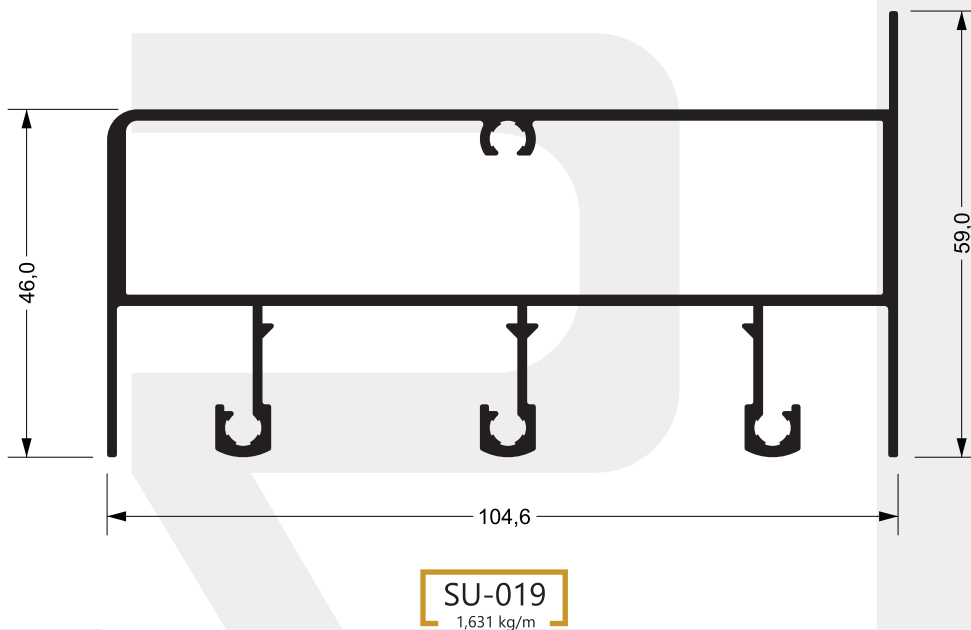
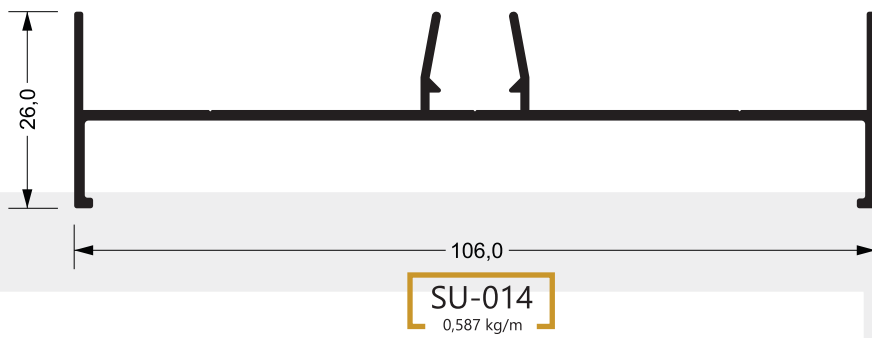
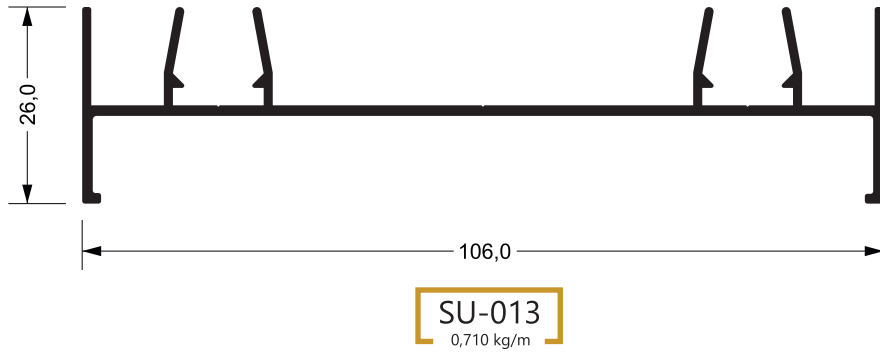



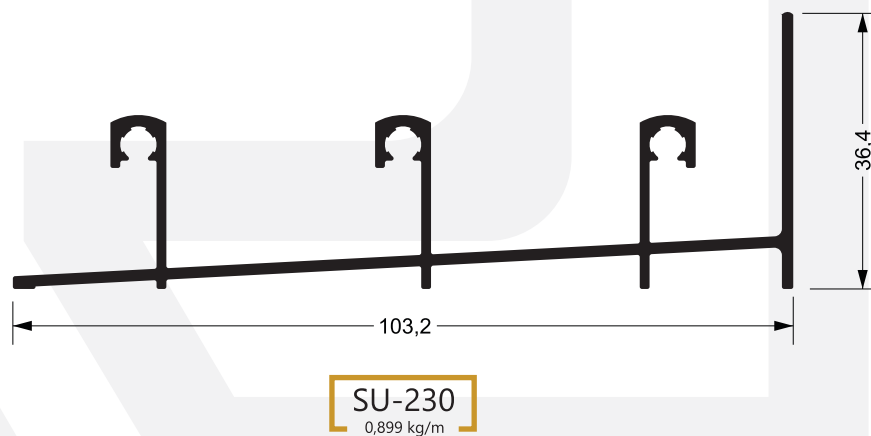
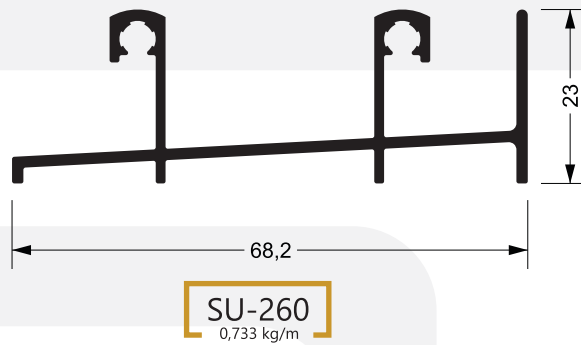
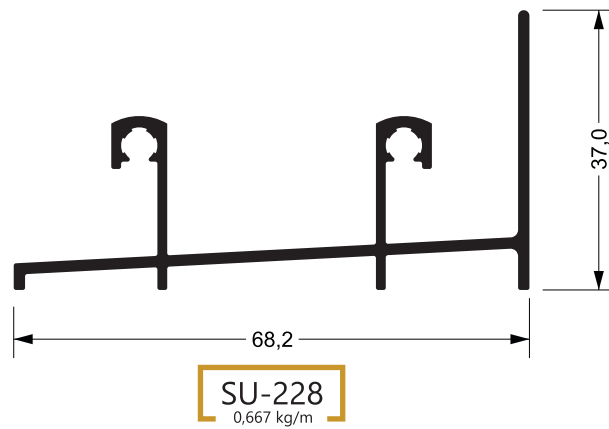
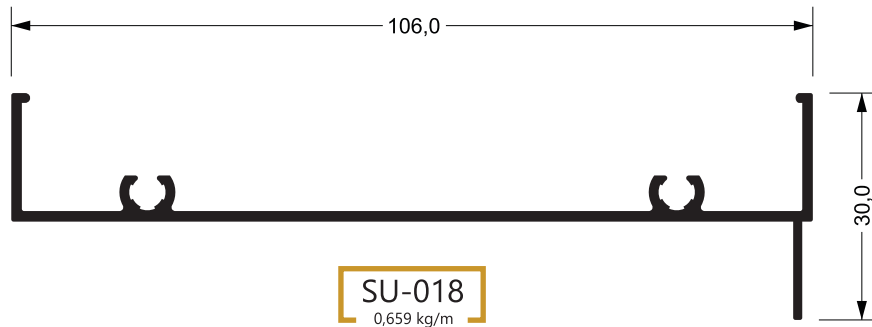

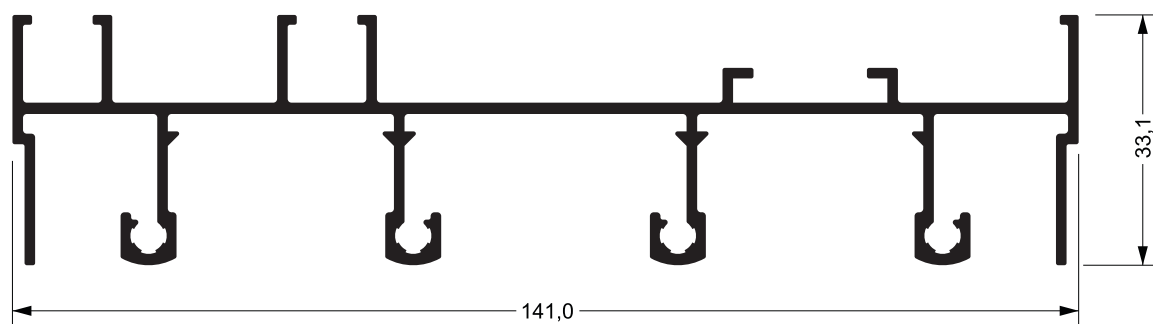

**SU-121**  
1,461 kg/m

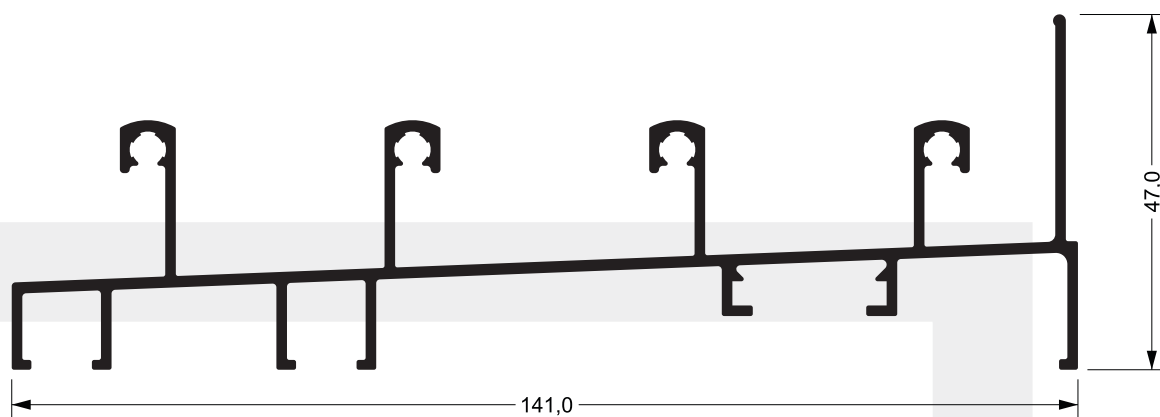

**SU-122**  
1,471 kg/m

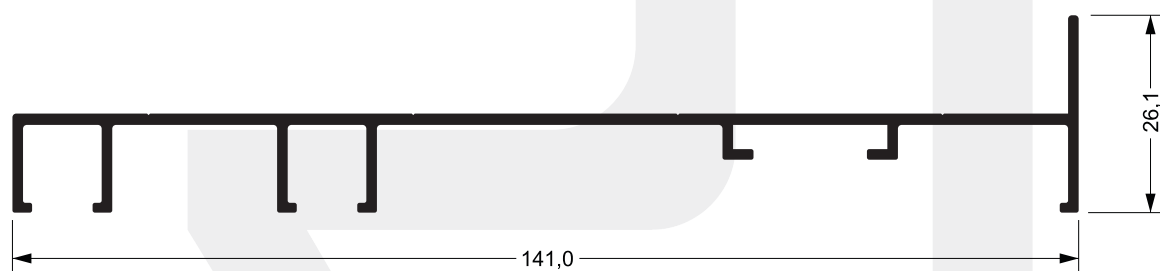

**SU-123**  
0,996 kg/m

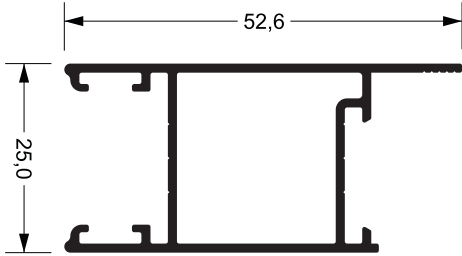

**SU-039**  
0,575 kg/m

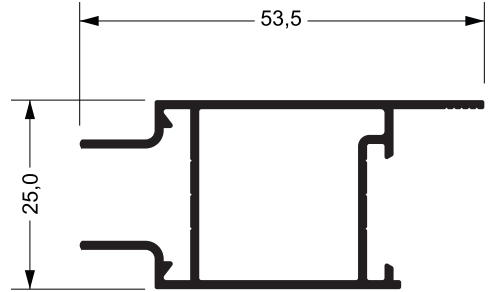

**SU-192**  
0,492 kg/m

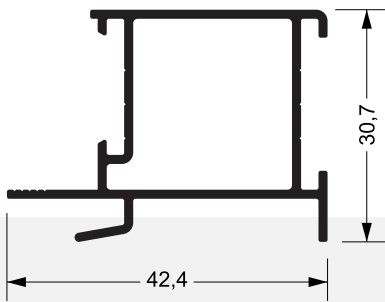

**SU-040**  
0,470 kg/m

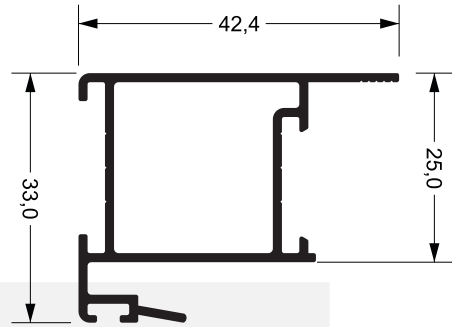

**SU-041**  
0,478 kg/m

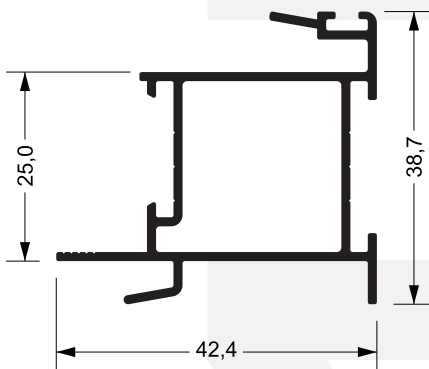

**SU-042**  
0,545 kg/m

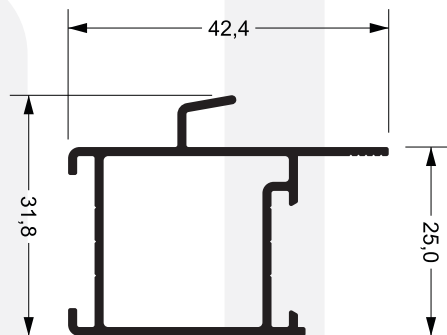

**SU-058**  
0,463 kg/m

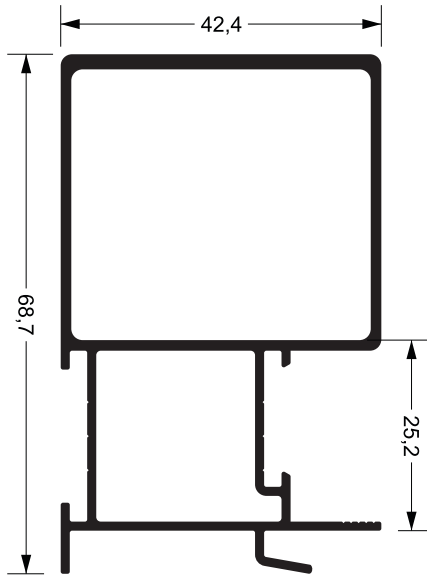

**SU-047**  
0,998 kg/m

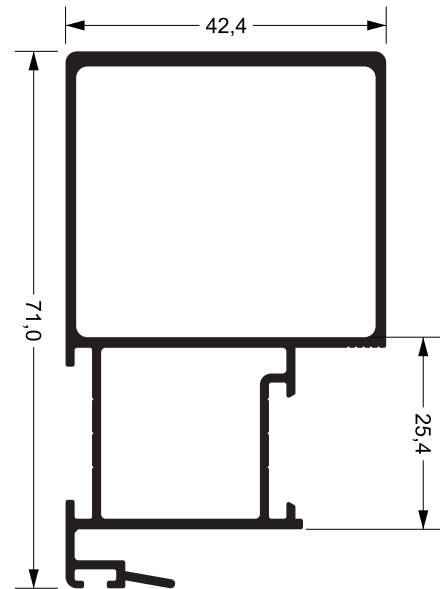

**SU-049**  
0,913 kg/m

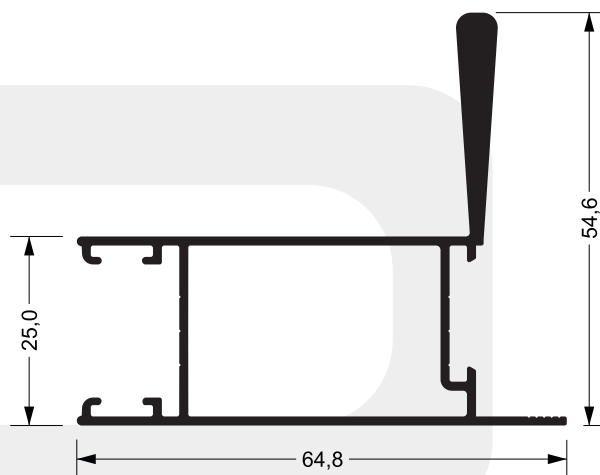

**SU-280**  
0,875 kg/m

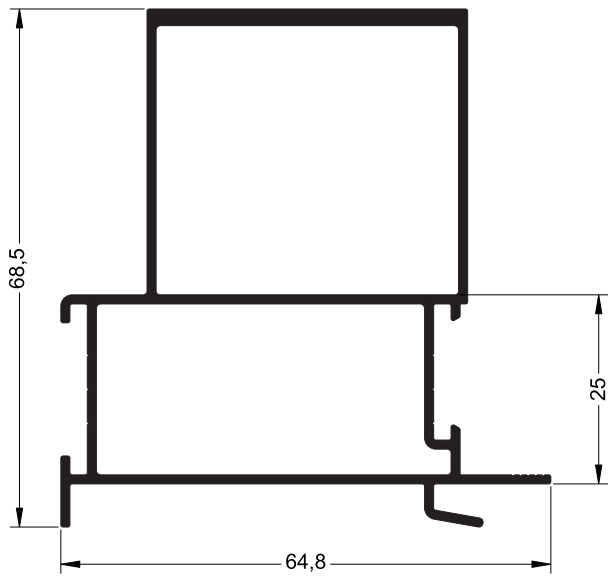

**SU-289**  
1,217 kg/m

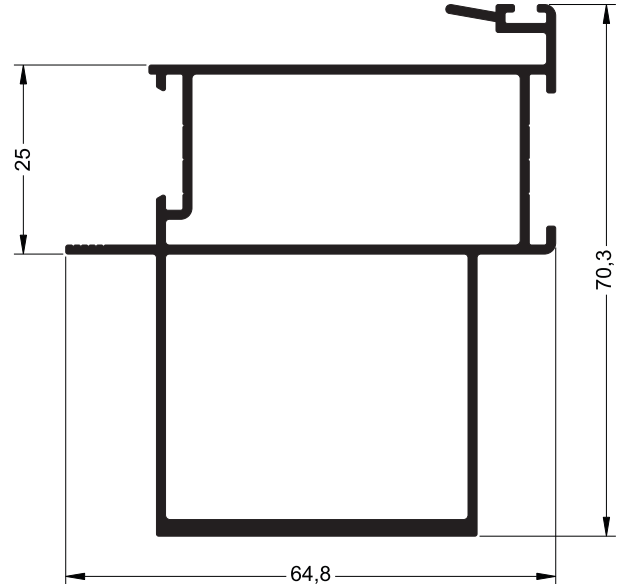

**SU-290**  
1,066 kg/m

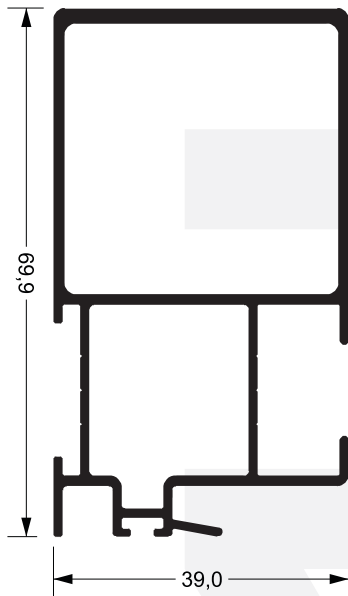

**SU-061**  
1,060 kg/m

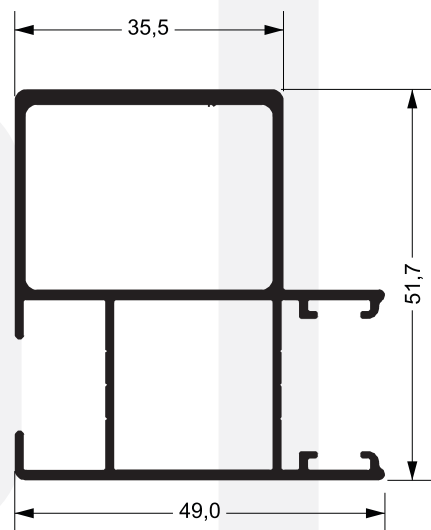

**SU-060**  
0,978 kg/m

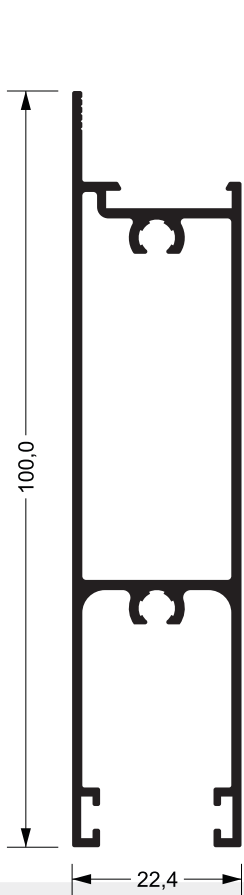

**SU-225**  
1,005 kg/m

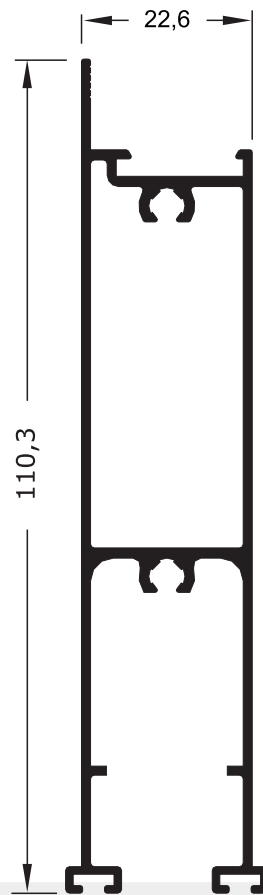

**SU-225B**  
0,999 kg/m

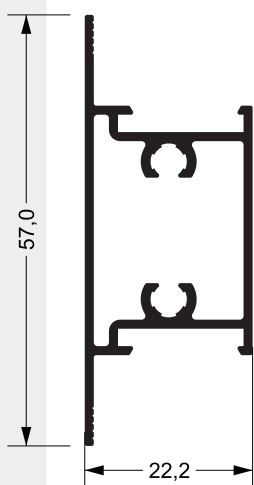

**SU-227**  
0,548 kg/m

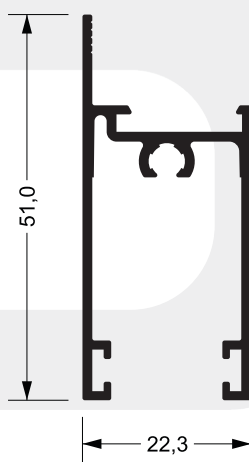

**SU-053**  
0,489 kg/m

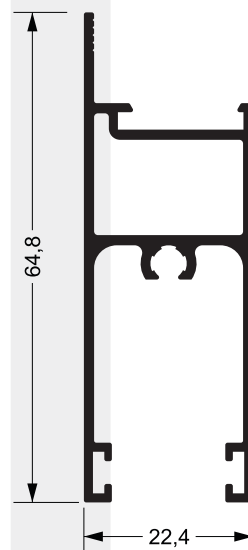

**SU-246**  
0,642 kg/m

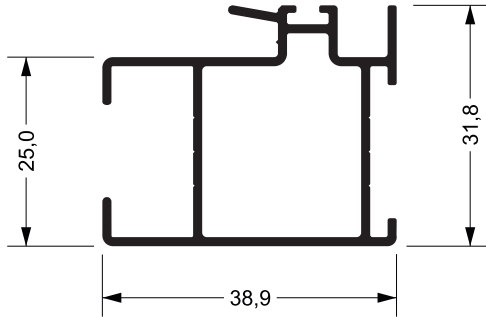

**SU-056**  
0,560 kg/m

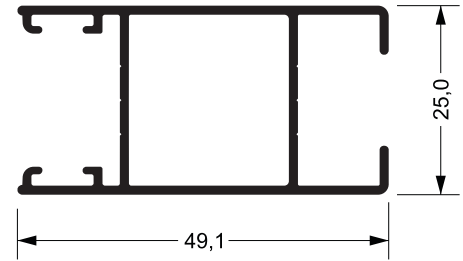

**SU-055**  
0,517 kg/m

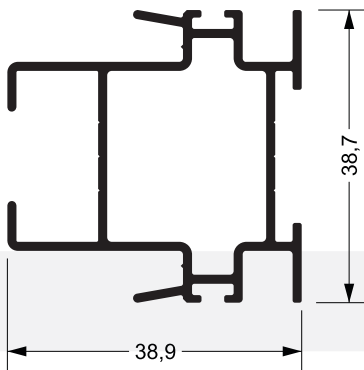

**SU-057**  
0,650 kg/m

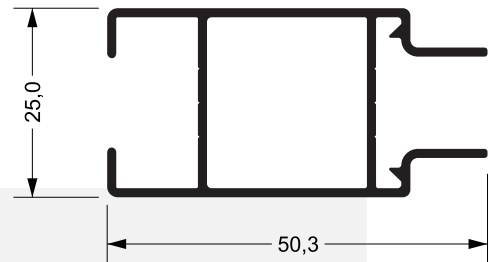

**SU-190**  
0,502 kg/m

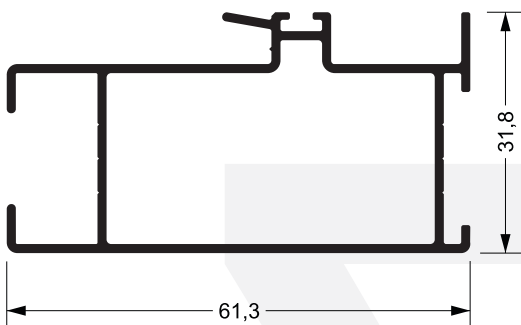

**SU-239**  
0,734 kg/m

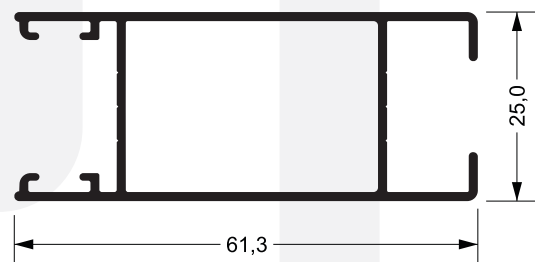

**SU-238**  
0,624 kg/m

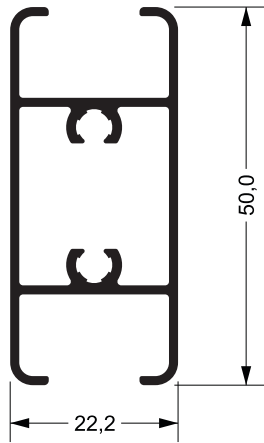

**SU-188**  
0,575 kg/m

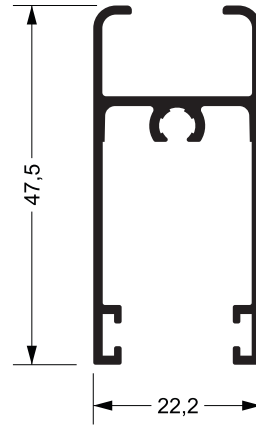

**SU-186**  
0,467 kg/m

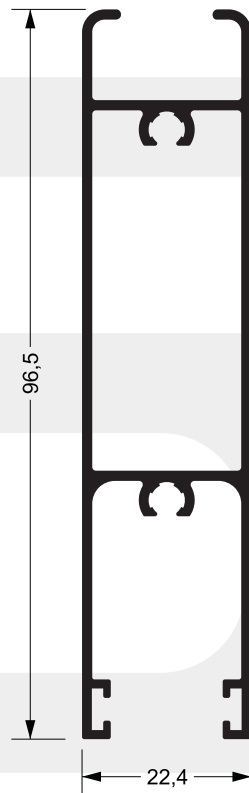

**SU-226**  
1,014 kg/m



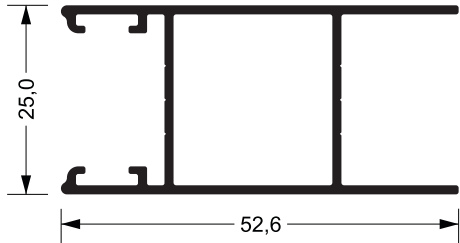

**SU-068**  
0,552 kg/m

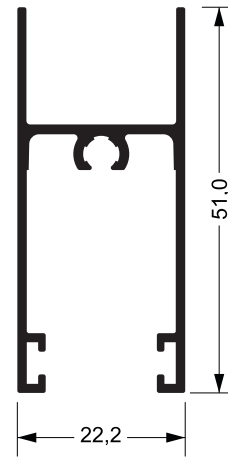

**SU-187**  
0,485 kg/m

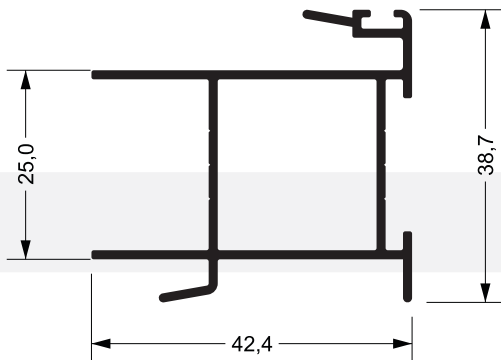

**SU-069**  
0,538 kg/m

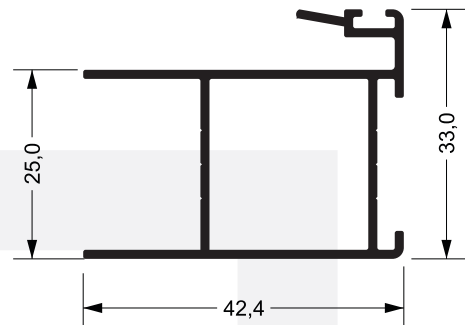

**SU-070**  
0,485 kg/m

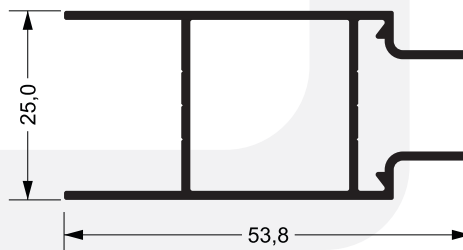

**SU-191**  
0,455 kg/m

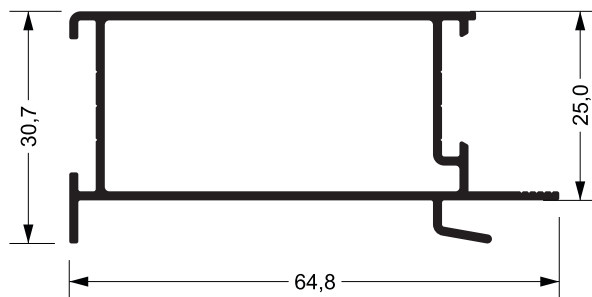

**SU-243**  
0,618 kg/m

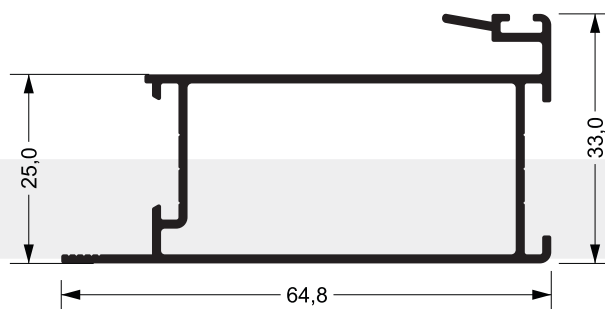

**SU-242**  
0,660 kg/m

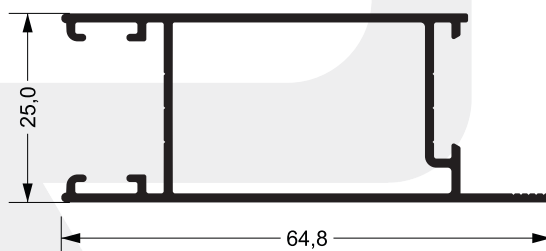

**SU-245**  
0,597 kg/m

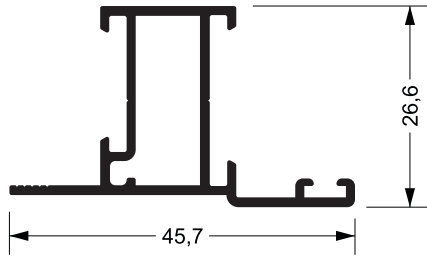

**SU-200**  
0,398 kg/m

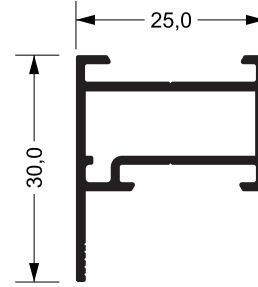

**SU-080**  
0,357 kg/m

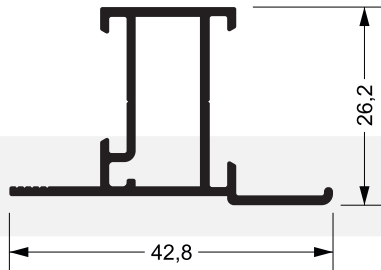

**SU-081**  
0,409 kg/m

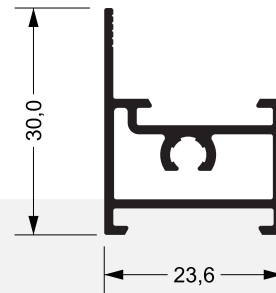

**SU-082**  
0,386 kg/m

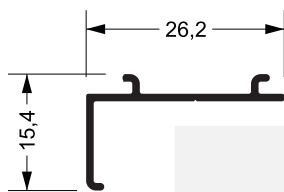

**SU-084**  
0,126 kg/m

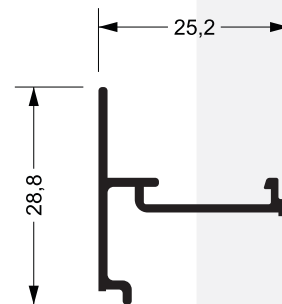

**SU-292**  
0,206 kg/m

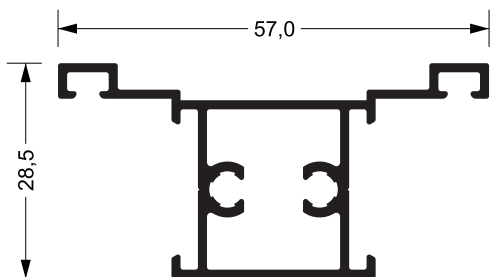

**SU-086**  
0,628 kg/m

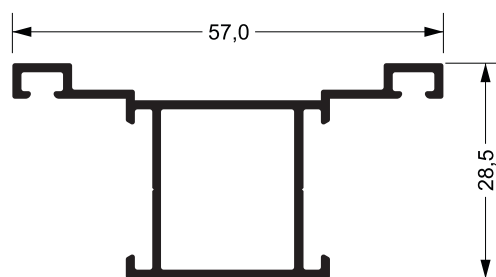

**SU-085**  
0,460 kg/m

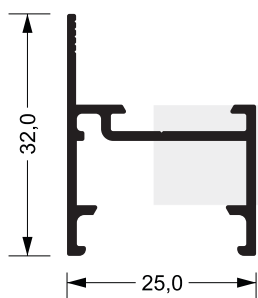

**SU-088**  
0,312 kg/m

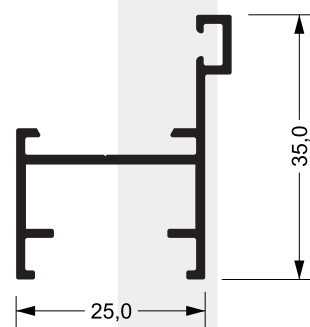

**SU-079**  
0,352 kg/m



**raltex**  
PERFIS DE ALUMÍNIO

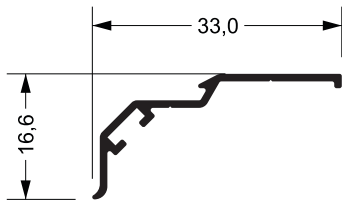

**SU-083**  
0,733 kg/m

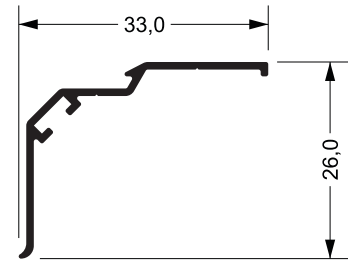

**SU-276**  
0,168 kg/m

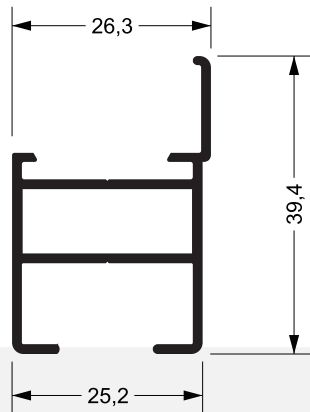

**SU-090**  
0,453 kg/m

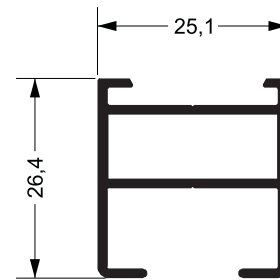

**SU-091**  
0,401 kg/m

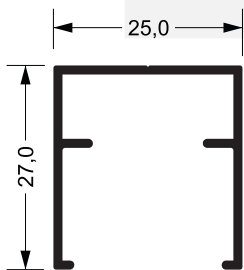

**SU-093**  
0,282 kg/m

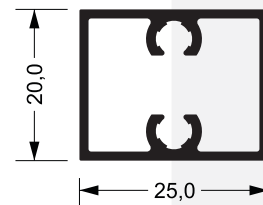

**SU-094**  
0,371 kg/m

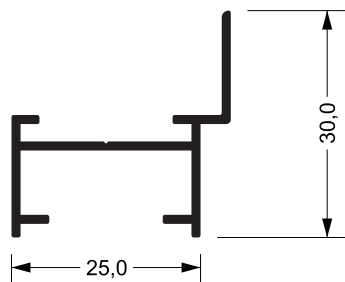

**SU-071**  
0,285 kg/m

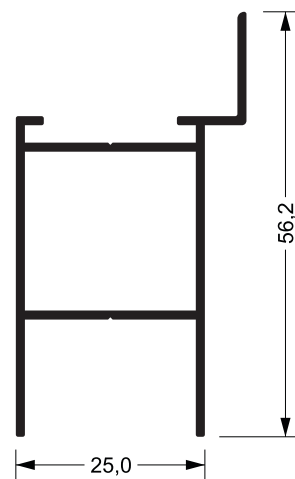

**SU-074**  
0,439 kg/m

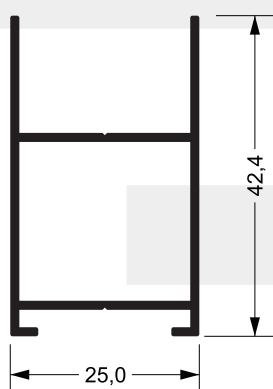

**SU-072**  
0,439 kg/m

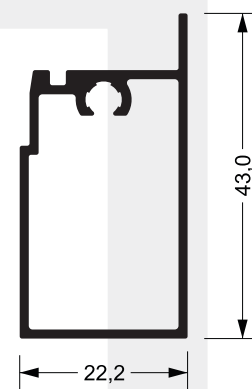

**SU-073**  
0,447 kg/m

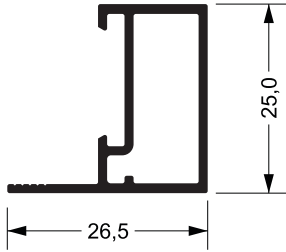

**SU-096**  
0,280 kg/m

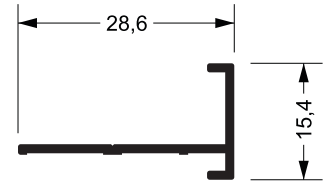

**SU-100**  
0,157 kg/m

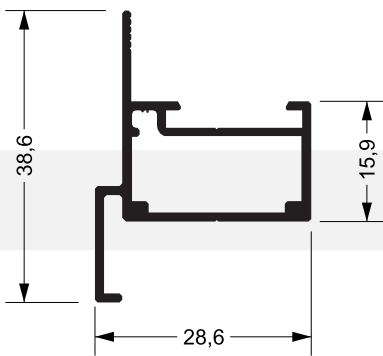

**SU-097**  
0,401 kg/m

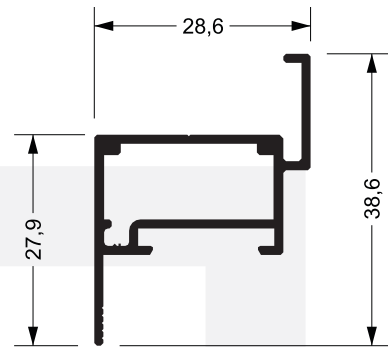

**SU-098**  
0,401 kg/m

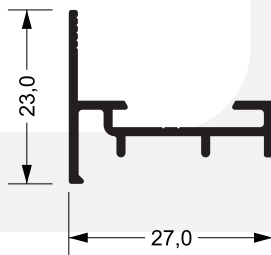

**SU-099**  
0,230 kg/m

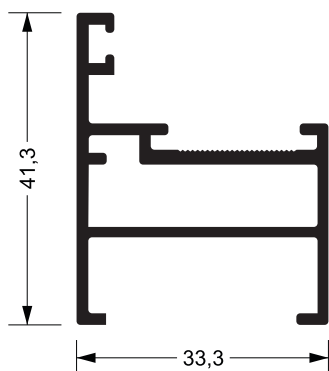

**SU-279**  
0,522 kg/m

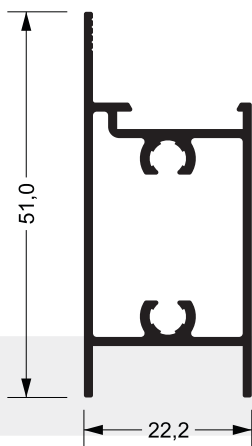

**SU-110**  
0,534 kg/m

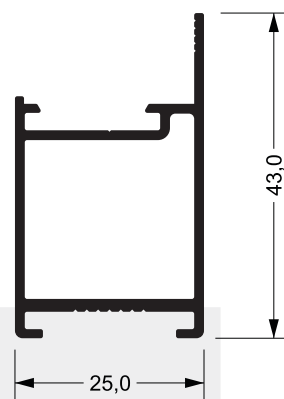

**SU-120**  
0,401 kg/m

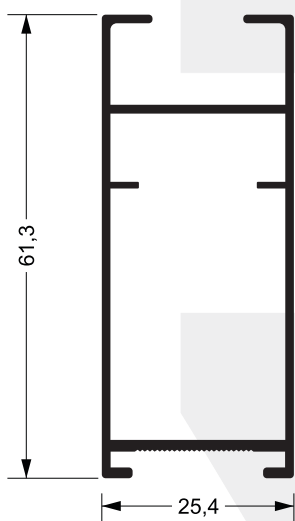

**SU-241**  
0,567 kg/m

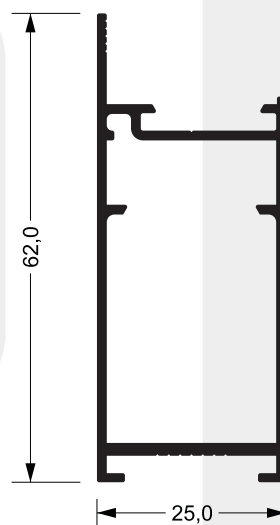

**SU-111**  
0,619 kg/m



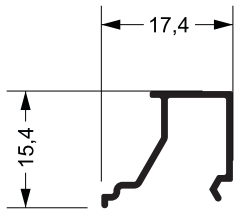

**SU-102**  
0,104 kg/m

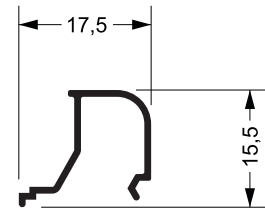

**AF-018**  
0,103 kg/m

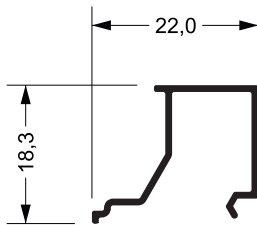

**SU-103**  
0,137 kg/m

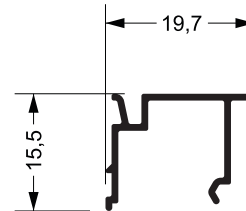

**SU-203**  
0,137 kg/m

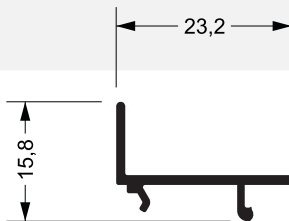

**SU-108**  
0,145 kg/m

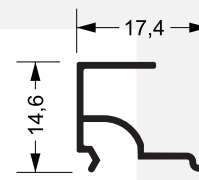

**SU-202**  
0,733 kg/m

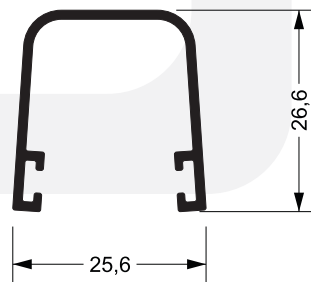

**SU-107**  
0,271 kg/m

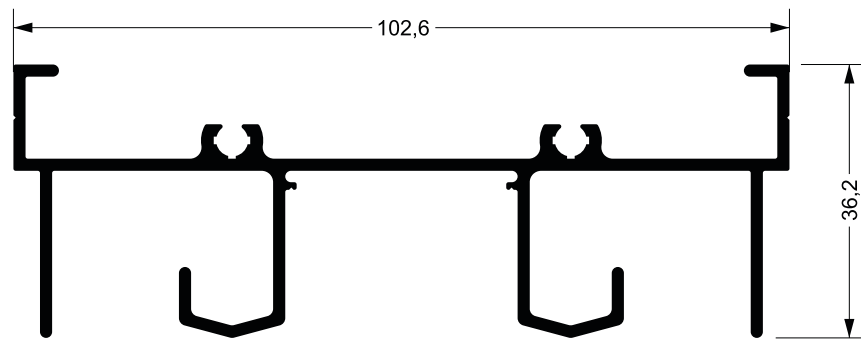

**LG-044**  
1,230 kg/m

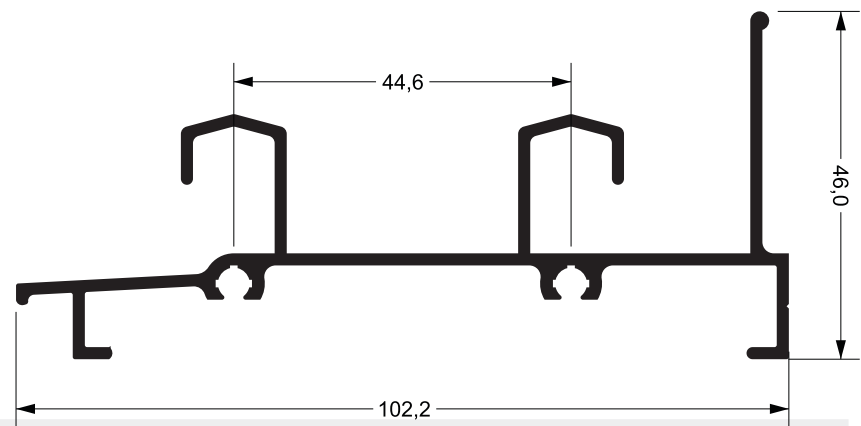

**LG-047**  
1,165 kg/m

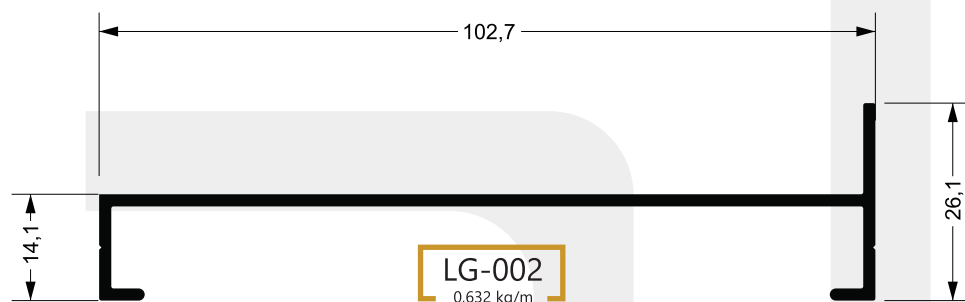

**LG-002**  
0,632 kg/m

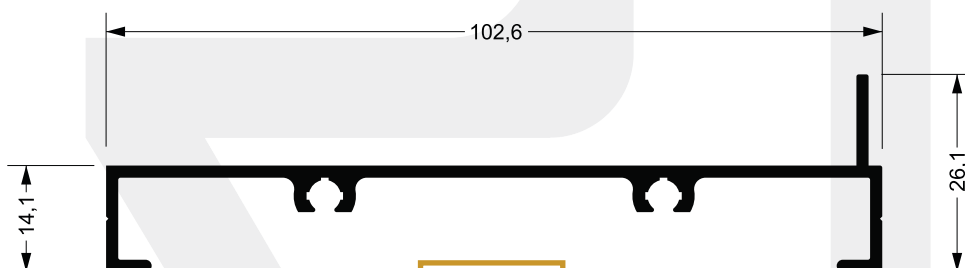

**LG-003**  
0,754 kg/m

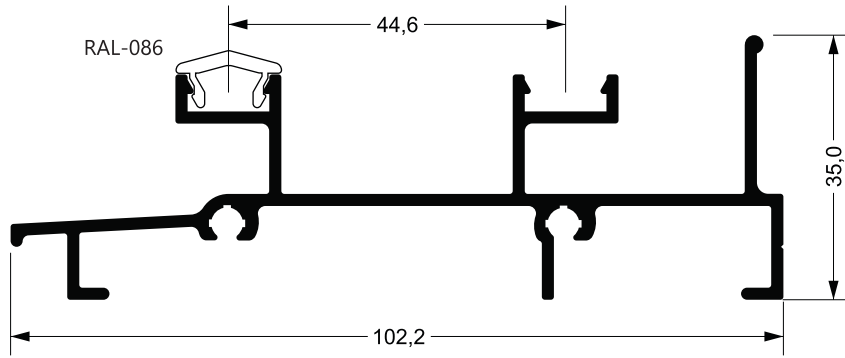

**RAL-083**  
1,138 kg/m

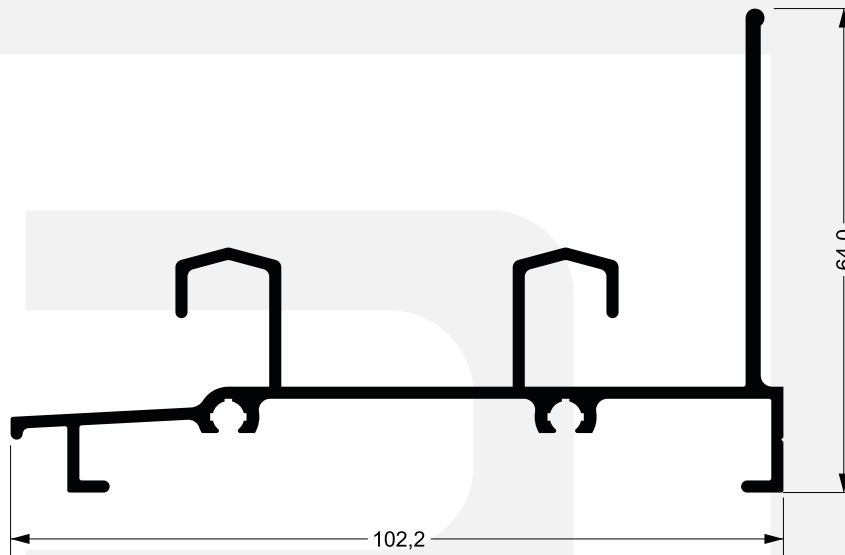

**LG-024**  
1,143 kg/m

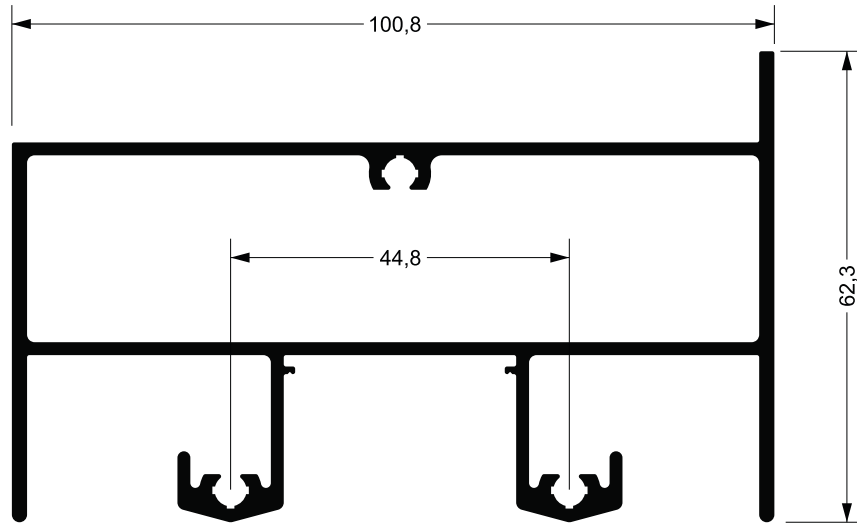

LG-004  
2,019 kg/m

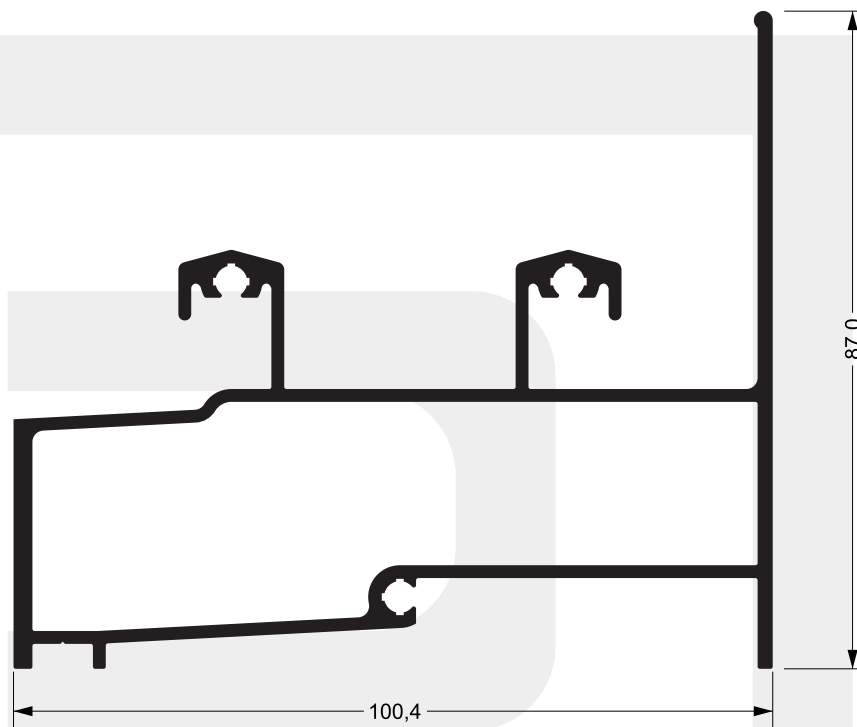

LG-005  
2,104 kg/m

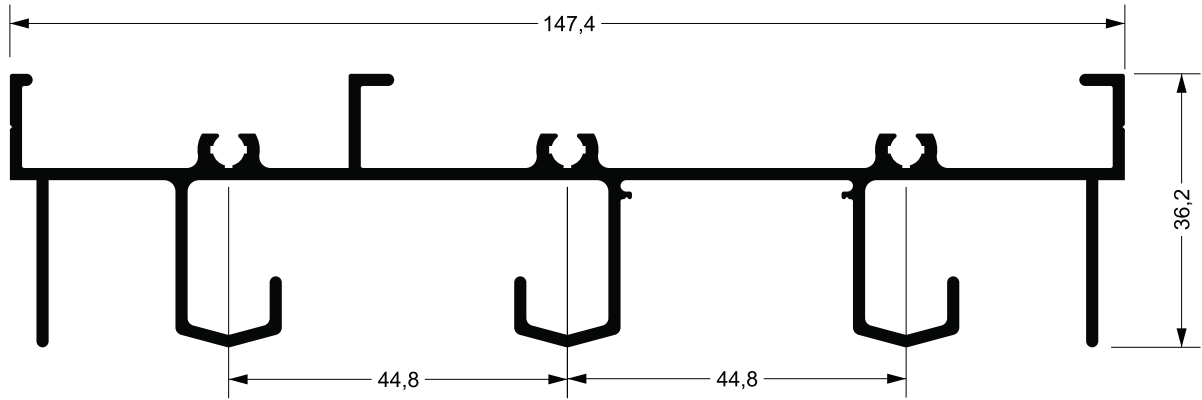

**LG-062**  
1,780 kg/m

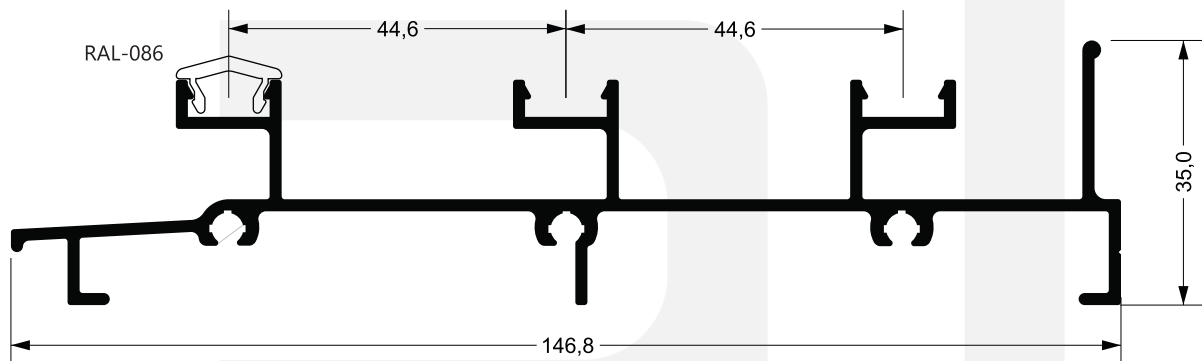

**RAL-084**  
1,524 kg/m

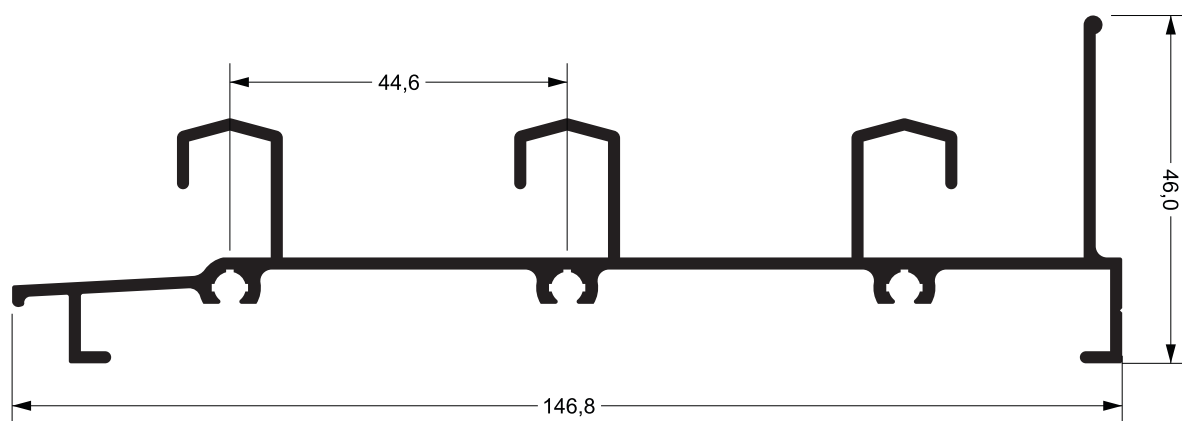

**RAL-066**  
1,455 kg/m

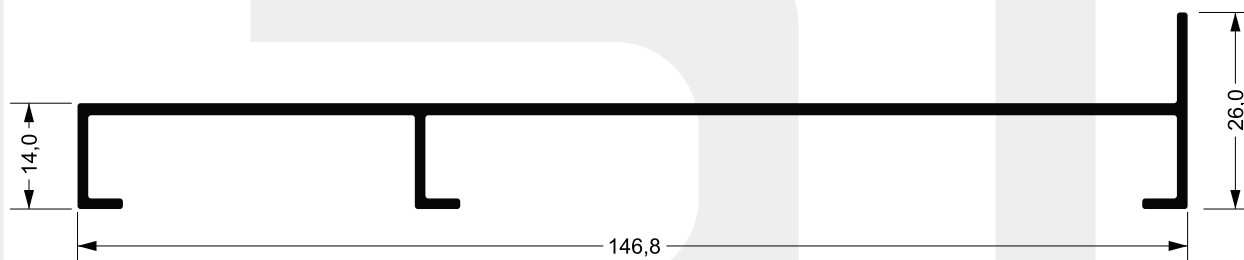

**LG-158**  
0,876 kg/m

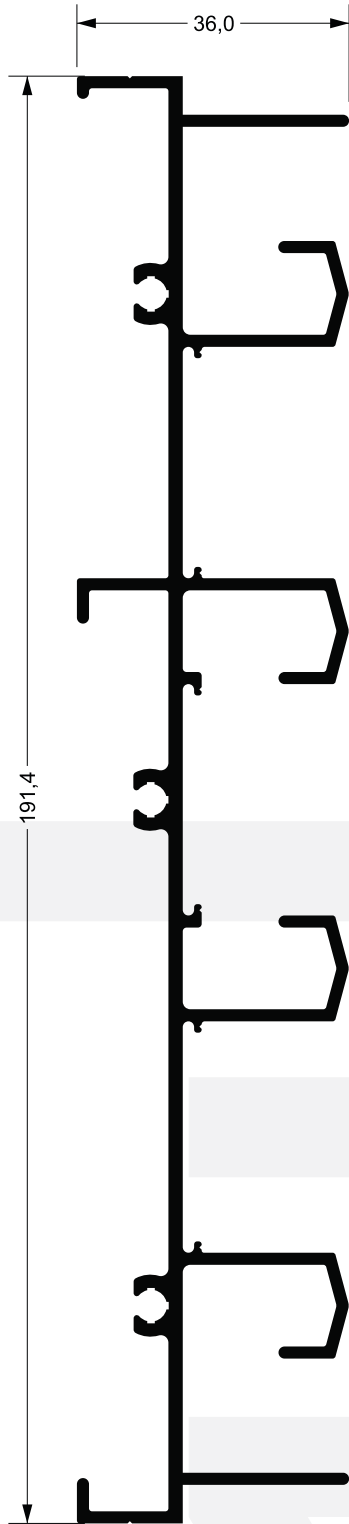

**LG-070**  
2,075 kg/m

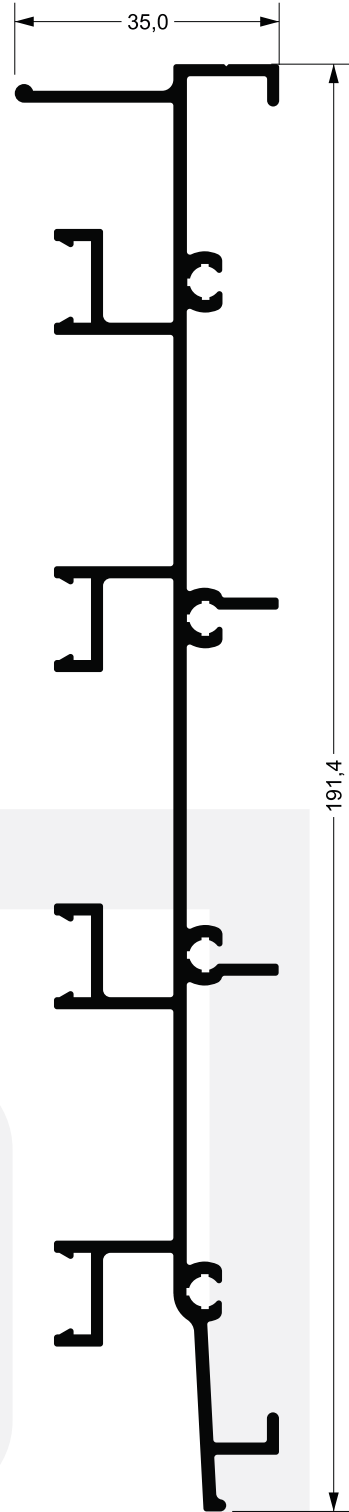

**RAL-085**  
1,805 kg/m

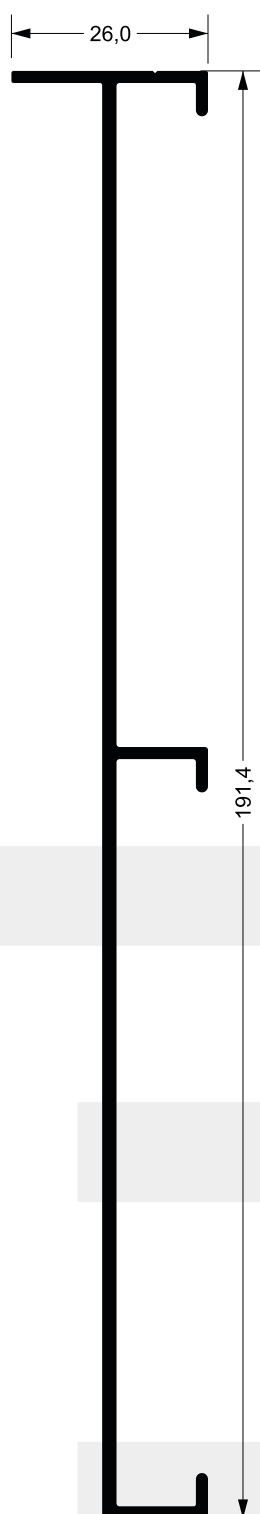

LG-072  
1,098 kg/m

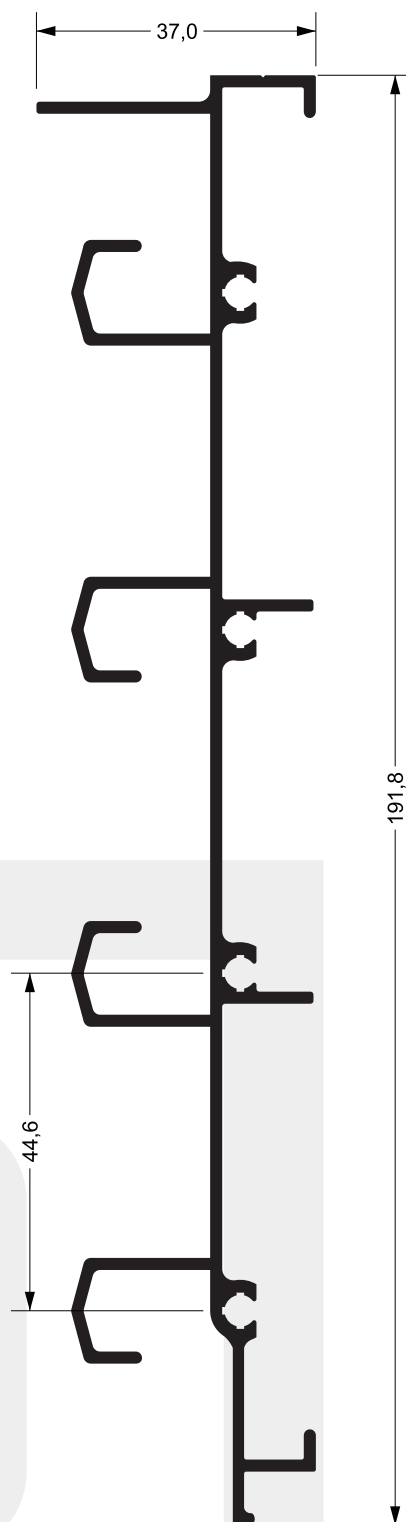

LG-071  
1,962 kg/m



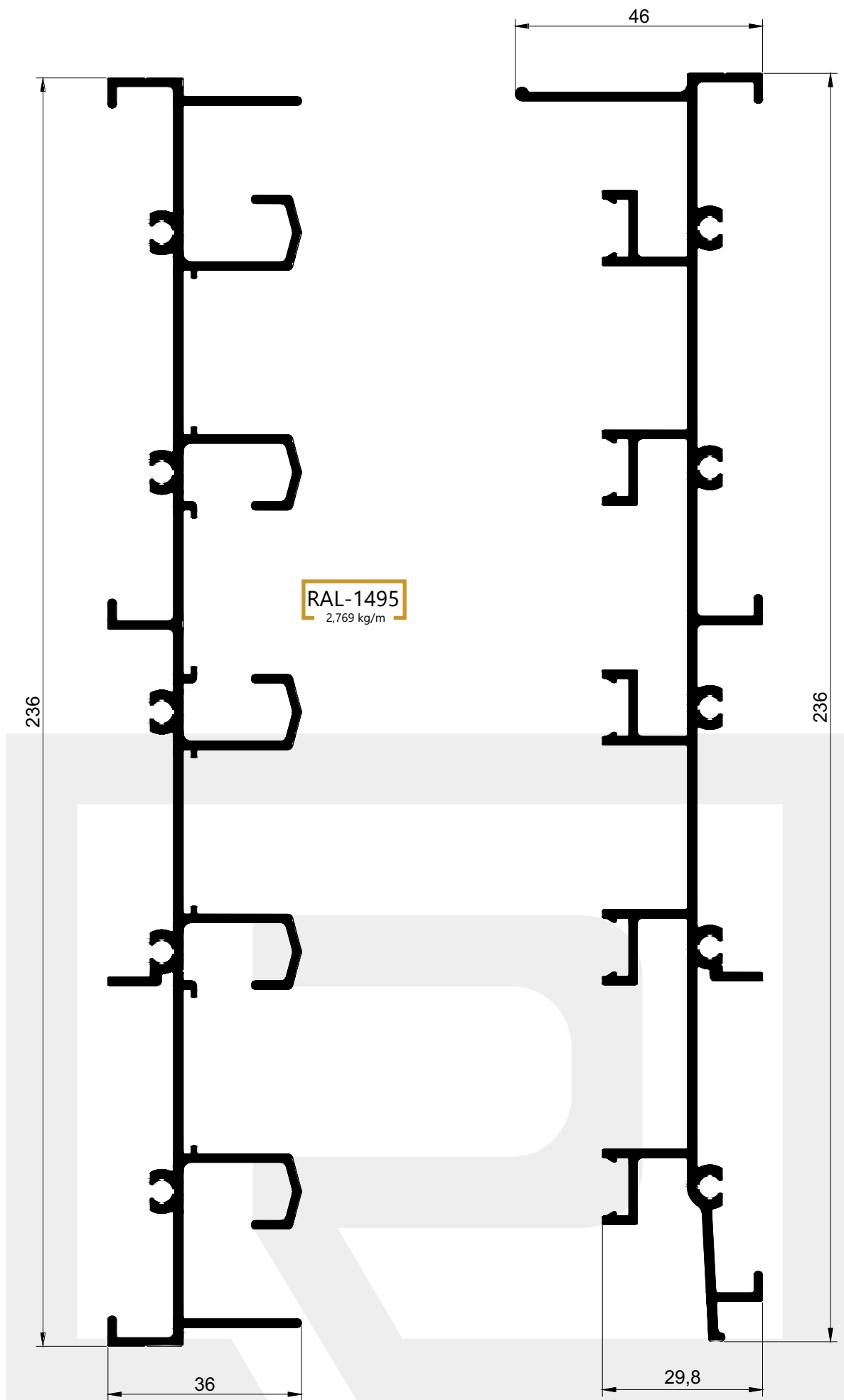

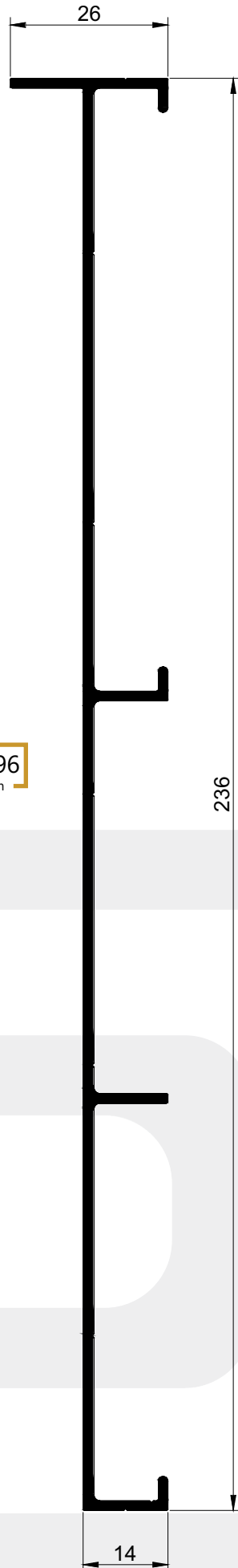

**RAL-1496**  
1,583 kg/m

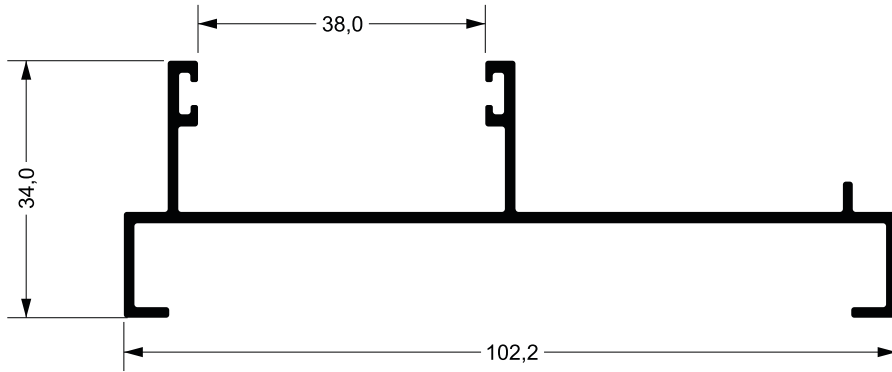

**LG-124**  
0,773 kg/m

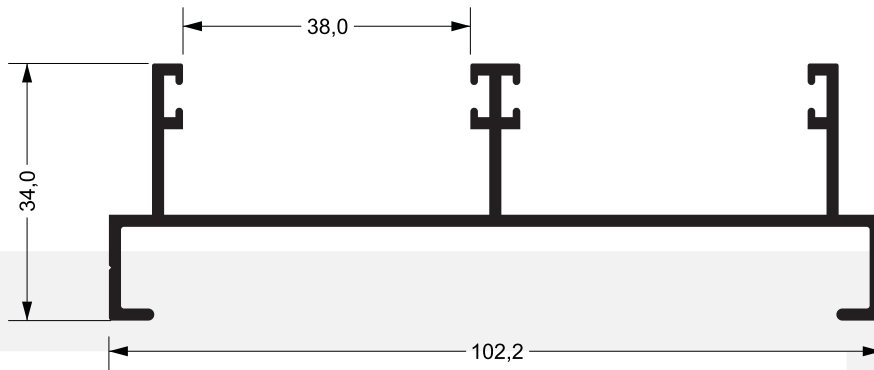

**LG-045**  
0,651 kg/m

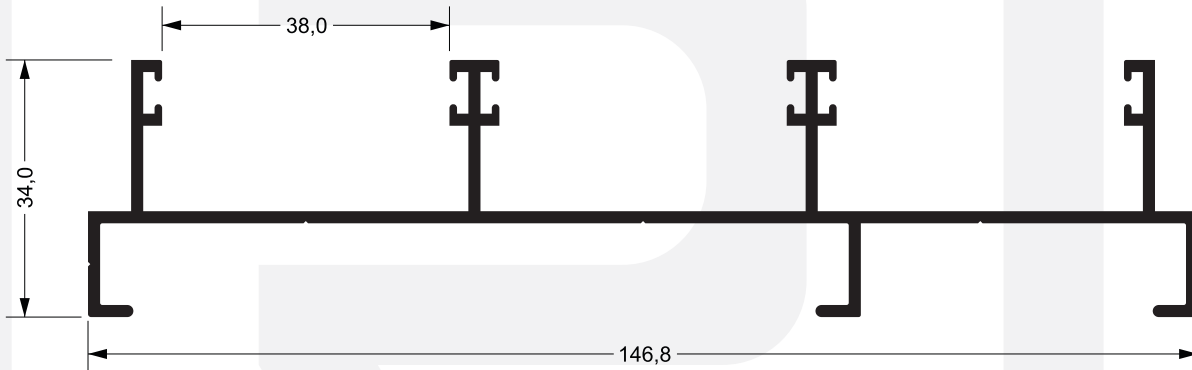

**LG-064**  
1,282 kg/m

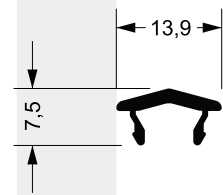
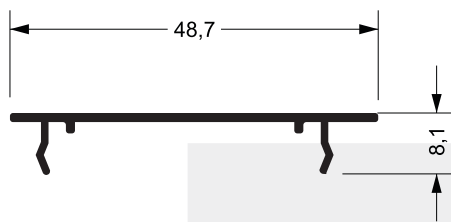
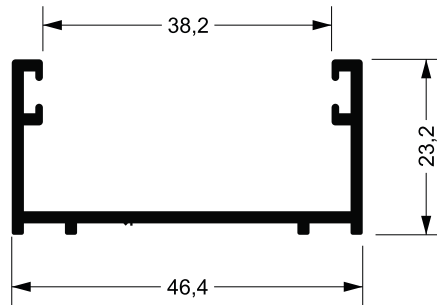
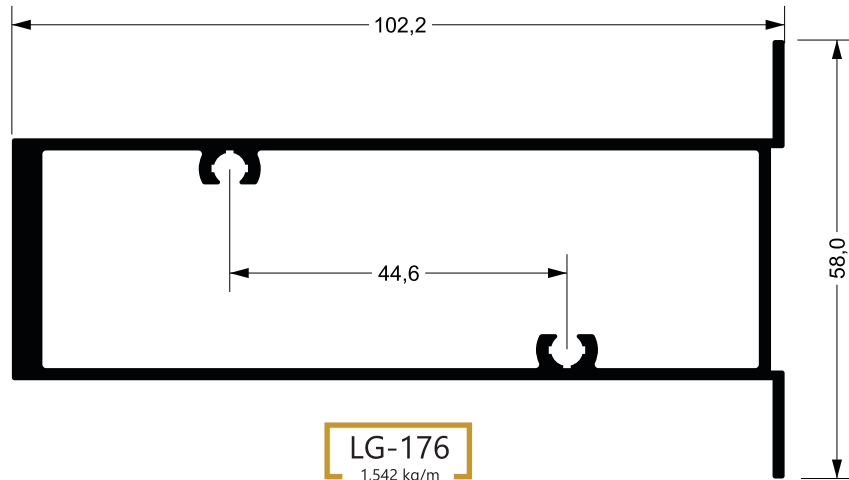

**LG-046**  
0,204 kg/m

**LG-111**  
0,127 kg/m

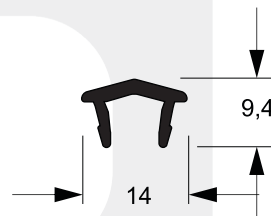
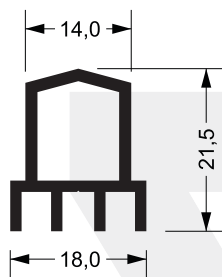

**RAL-086**  
0,114 kg/m

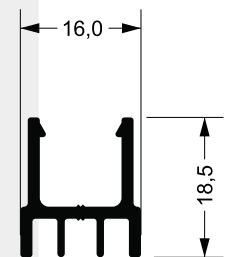

**LG-157**  
0,251 kg/m

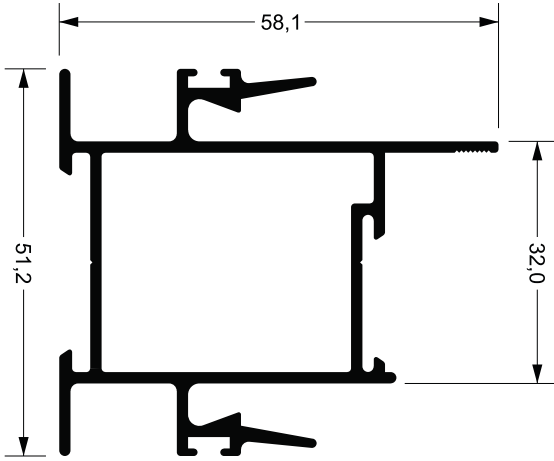

**LG-162**  
1,074 kg/m

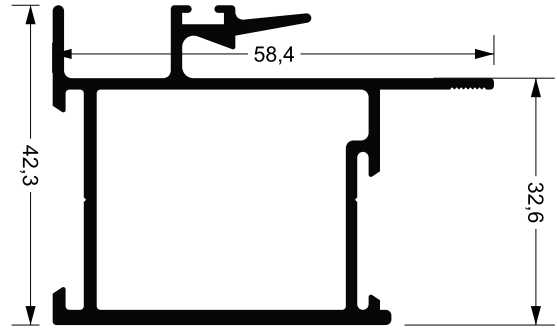

**LG-048**  
0,959 kg/m

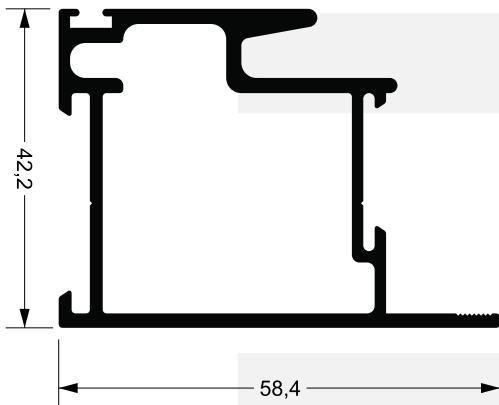

**LG-019**  
1,079 kg/m

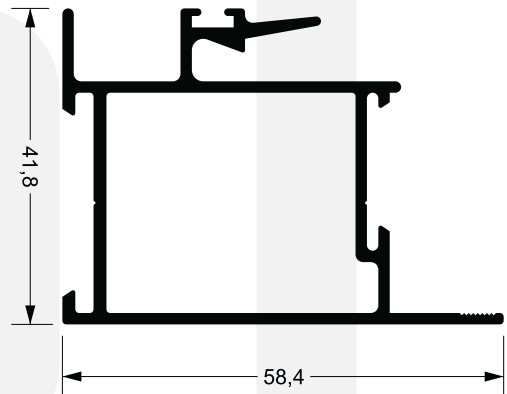

**LG-049**  
0,959 kg/m

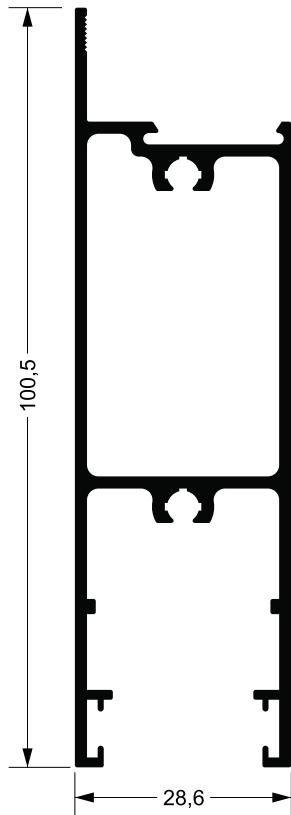

**LG-007**  
1,200 kg/m

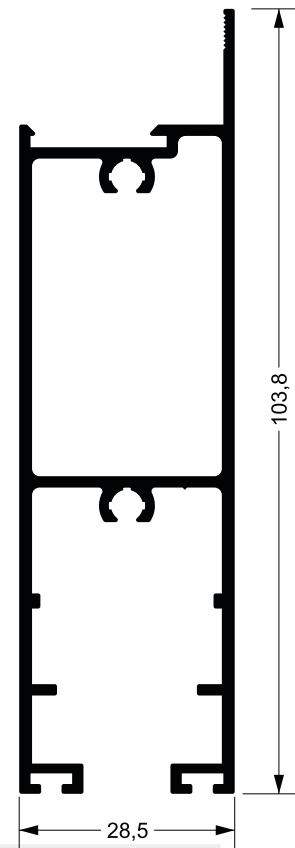

**LG-007/B**  
1,280 kg/m

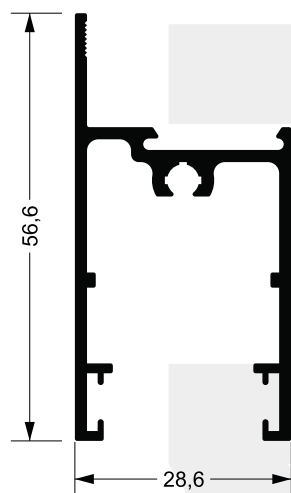

**LG-006**  
0,664 kg/m

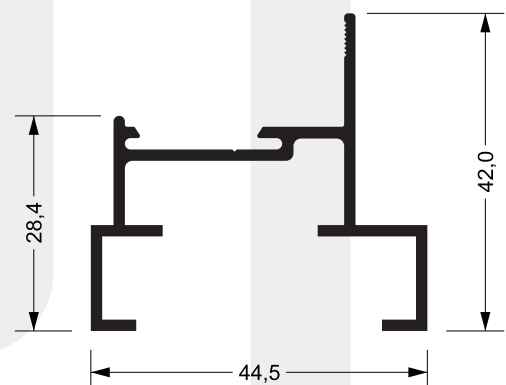

**LG-063**  
0,549 kg/m

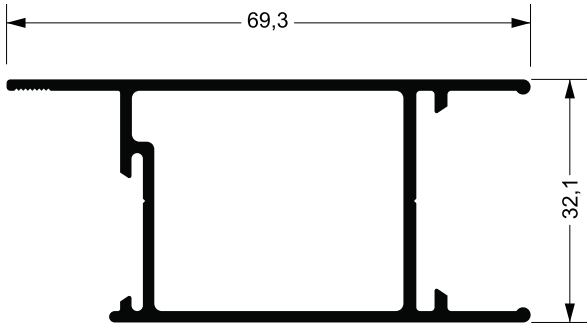

**LG-050**  
0,787 kg/m

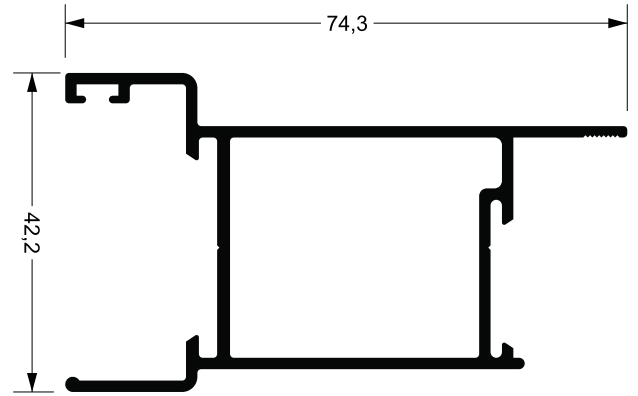

**LG-051**  
0,900 kg/m

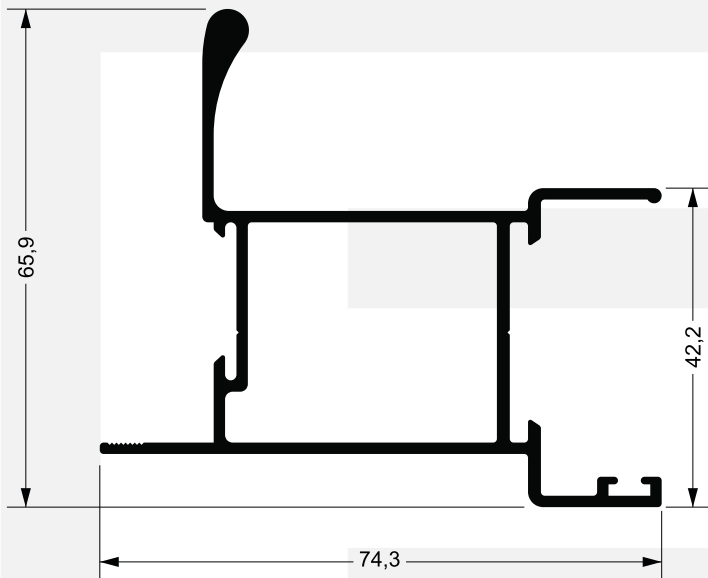

**LG-020**  
1,119 kg/m

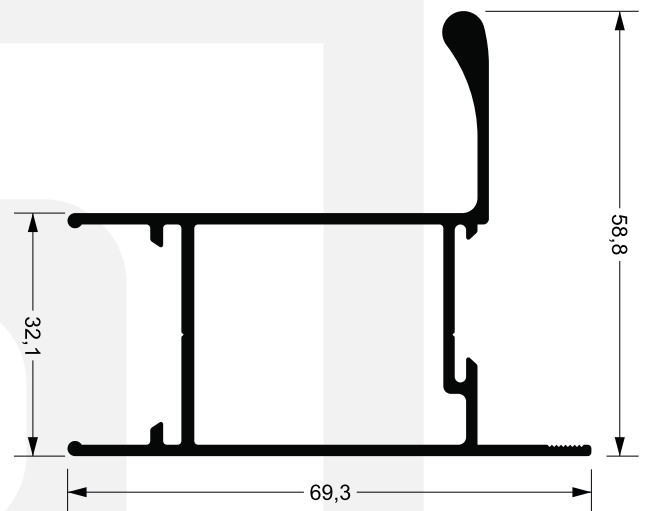

**LG-017**  
0,995 kg/m

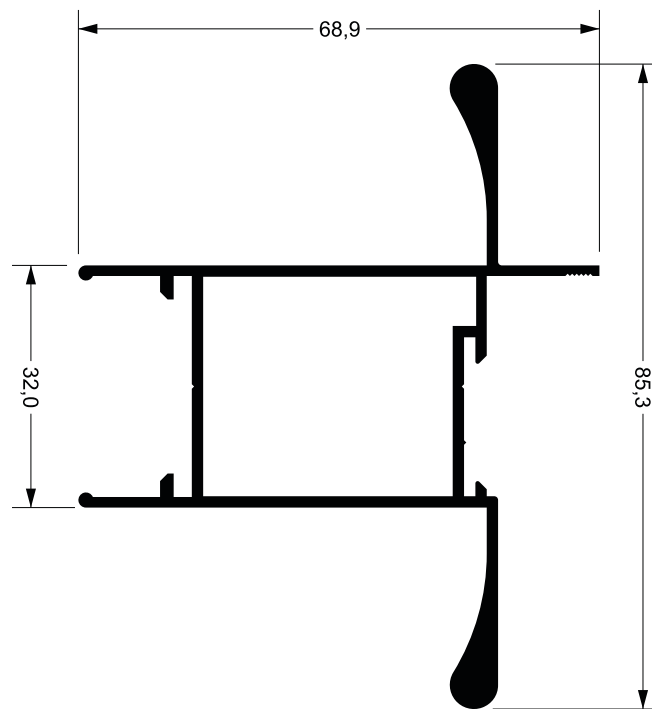

**LG-201**  
1,200 kg/m

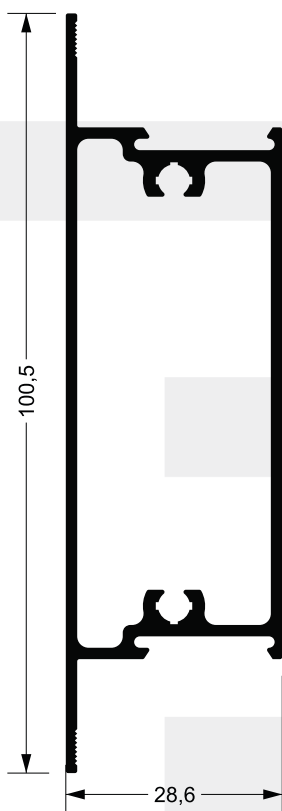

**LG-022**  
1,074 kg/m

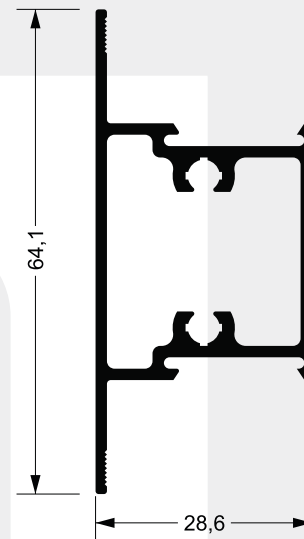

**LG-055**  
0,757 kg/m



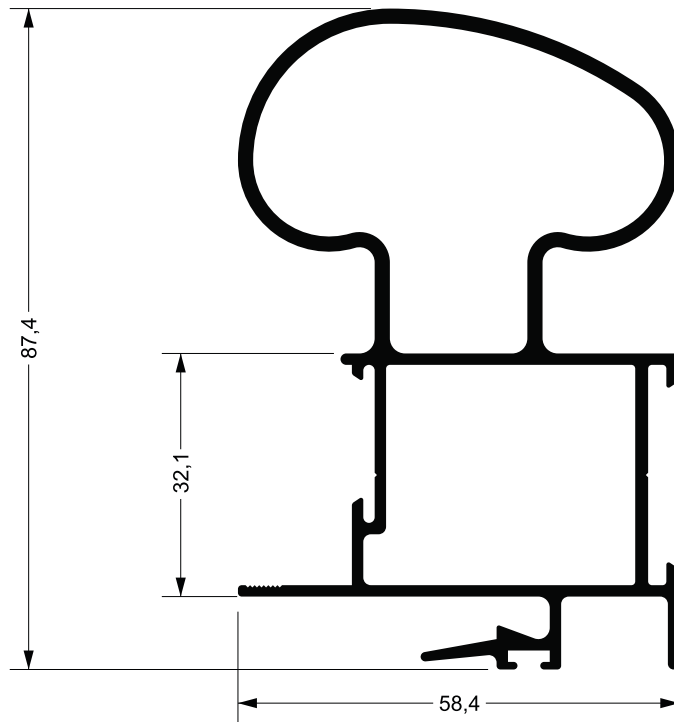

**LG-021**  
1,782 kg/m

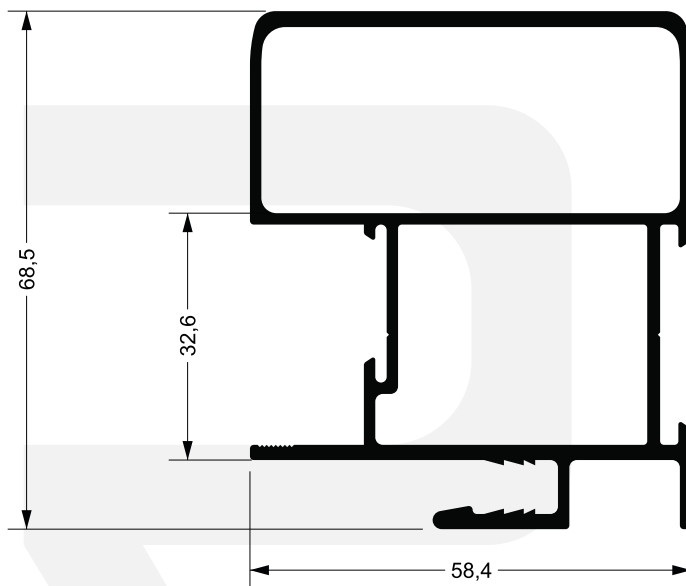

**LG-018**  
1,580 kg/m

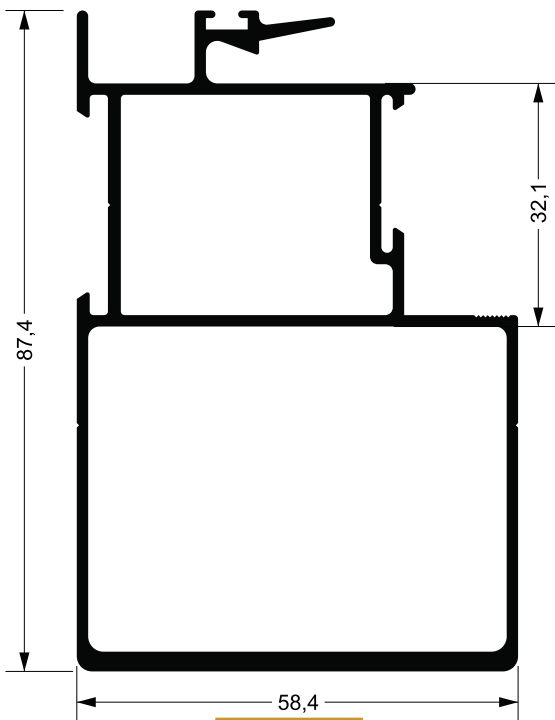

**LG-052**  
1,675 kg/m

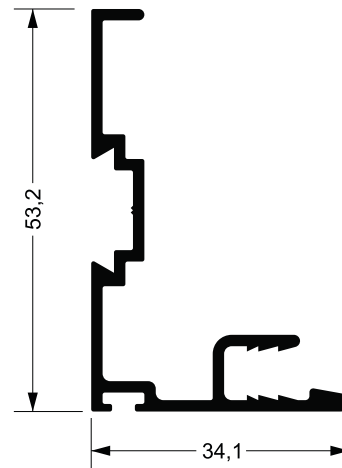

**LG-023**  
0,551 kg/m

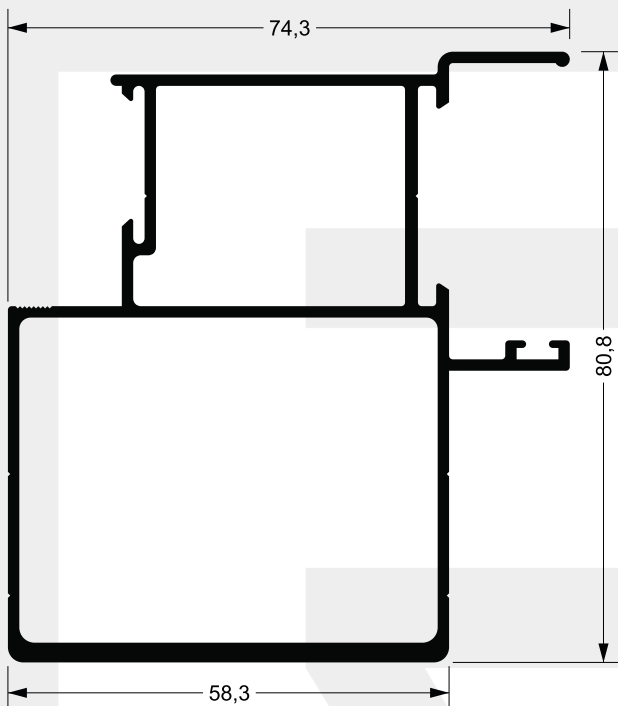

**LG-053**  
1,650 kg/m

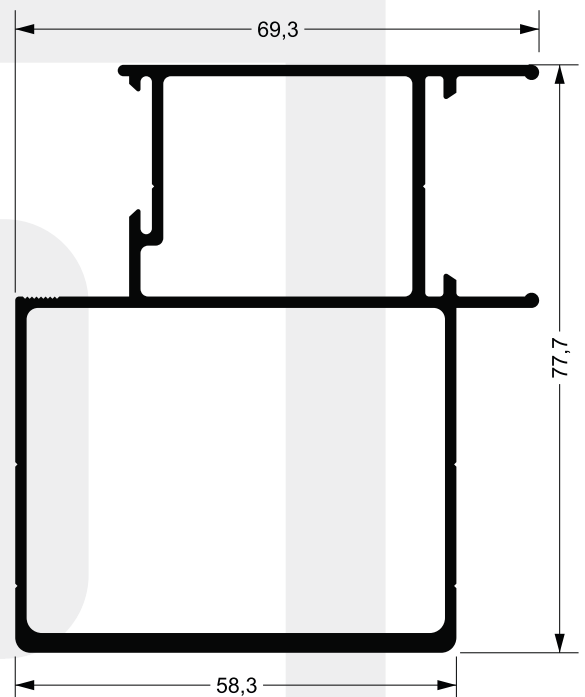

**LG-054**  
1,575 kg/m

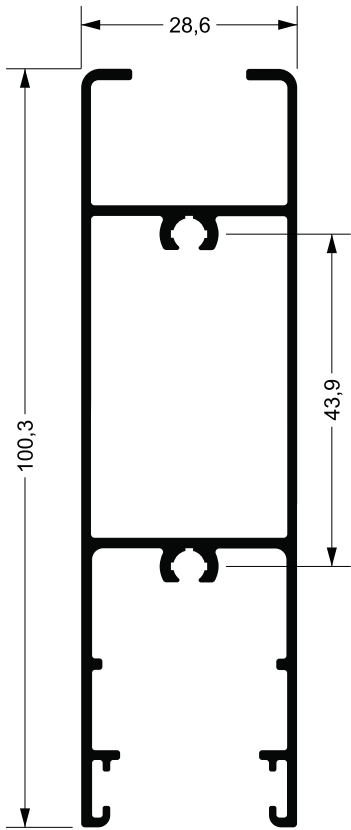

**RAL-007/SB**  
1,241 kg/m

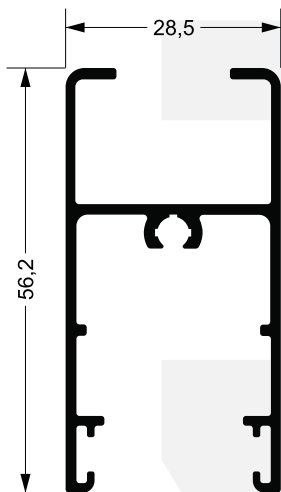

**RAL-006/SB**  
0,656 kg/m

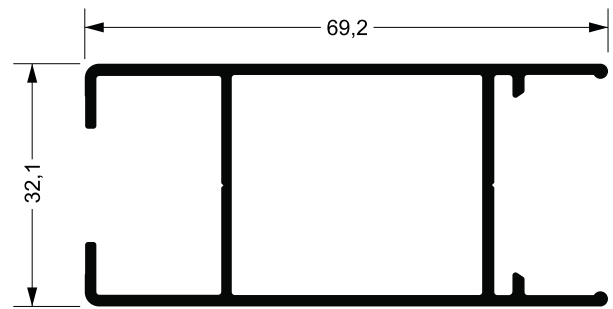

**RAL-050/SB**  
0,774 kg/m

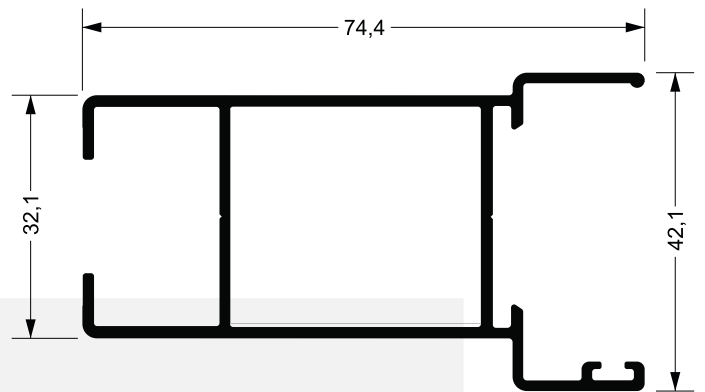

**RAL-051/SB**  
0,891 kg/m

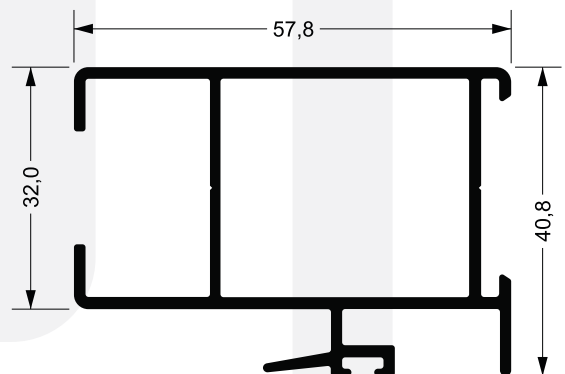

**RAL-049/SB**  
0,872 kg/m

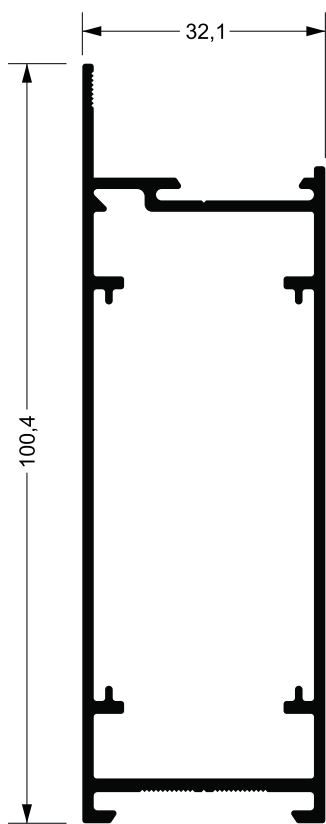

LG-042  
0,959 kg/m

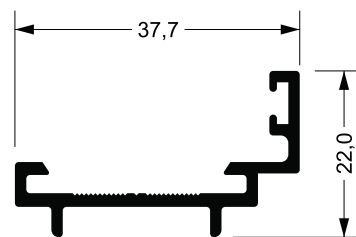

LG-016  
0,330 kg/m

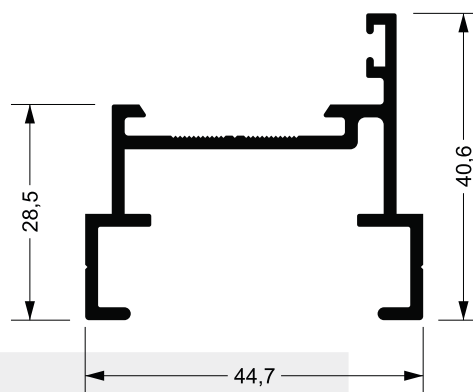

LG-056  
0,652 kg/m

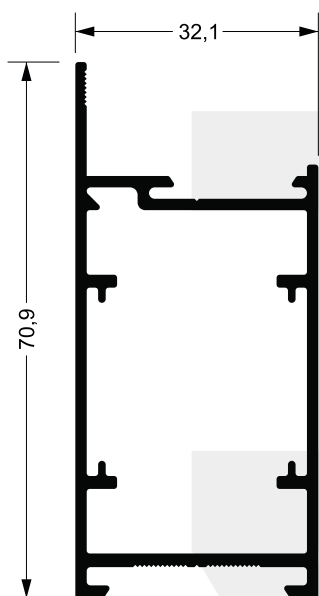

LG-043  
0,933 kg/m

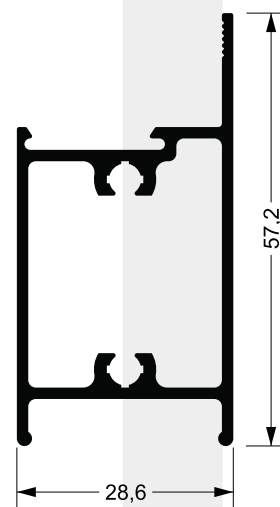

LG-058  
1,650 kg/m

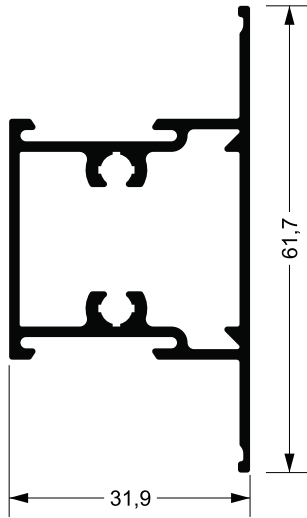

**LG-079**  
0,753 kg/m

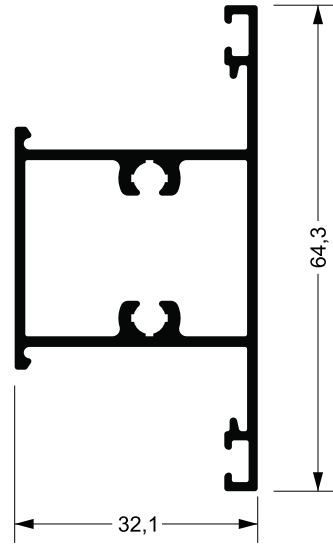

**LG-074**  
0,551 kg/m

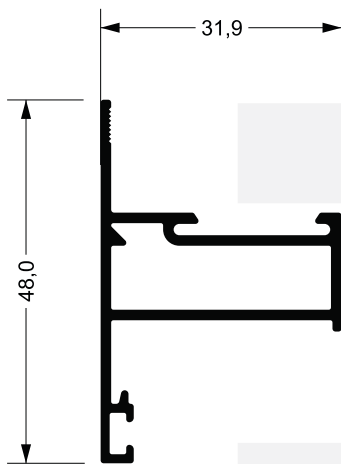

**LG-085**  
0,558 kg/m

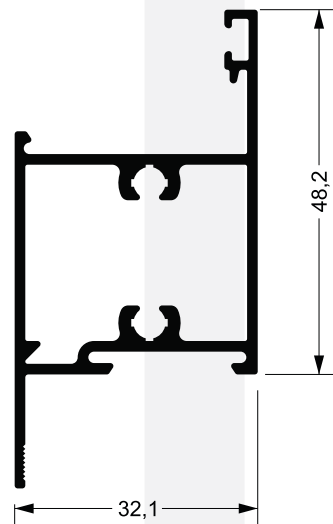

**LG-076**  
0,765 kg/m

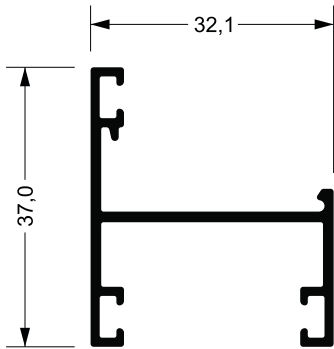

**LG-068**  
0,392 kg/m

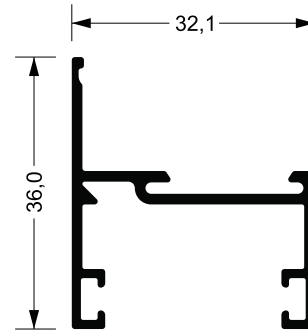

**LG-083**  
0,422 kg/m

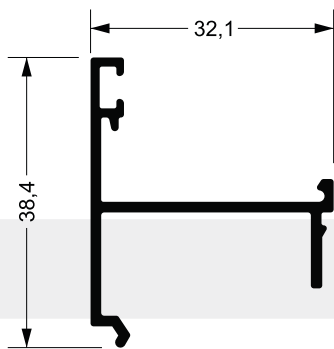

**LG-082**  
0,331 kg/m

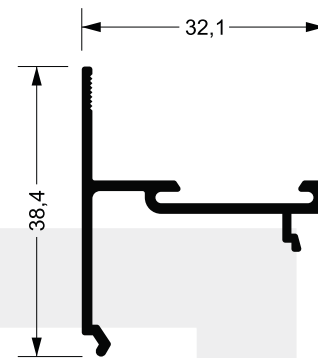

**LG-077**  
0,324 kg/m

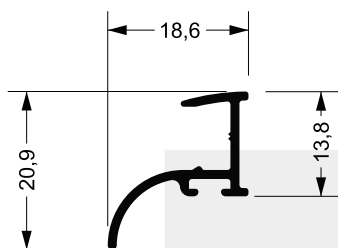

**LG-092**  
0,170 kg/m

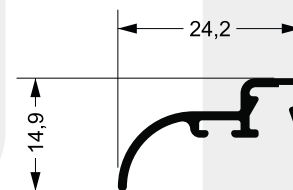

**LG-091**  
0,135 kg/m

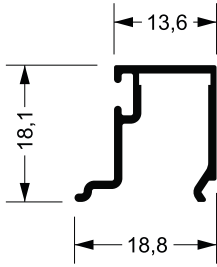

**BG-057**  
0,172 kg/m

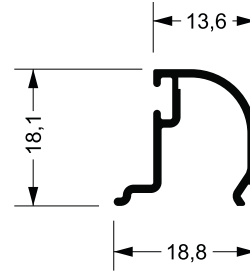

**LG-026**  
0,150 kg/m

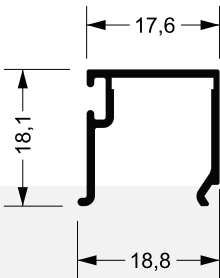

**LG-059**  
0,174 kg/m

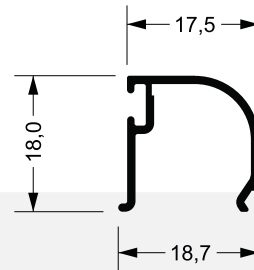

**LG-164**  
0,141 kg/m

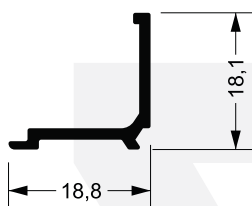

**LG-015**  
0,142 kg/m

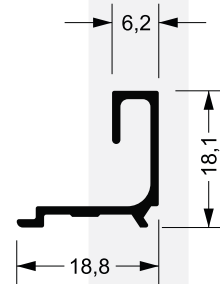

**LG-027**  
0,144 kg/m

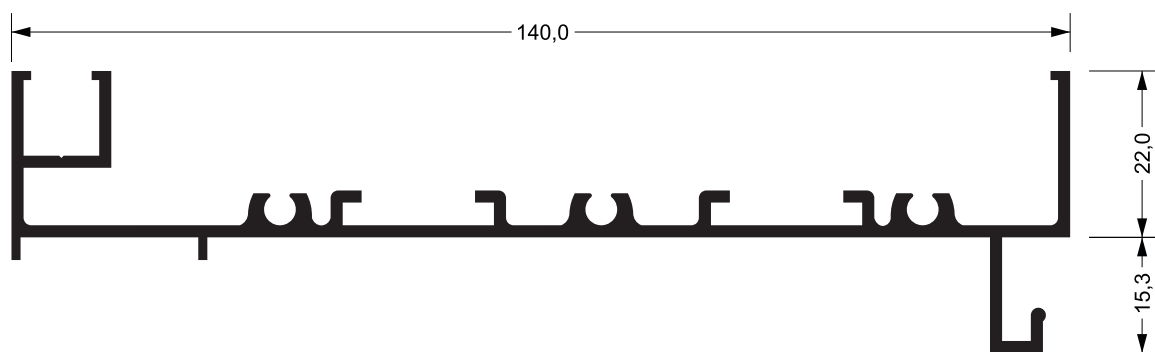

MN-001  
1,314 kg/m

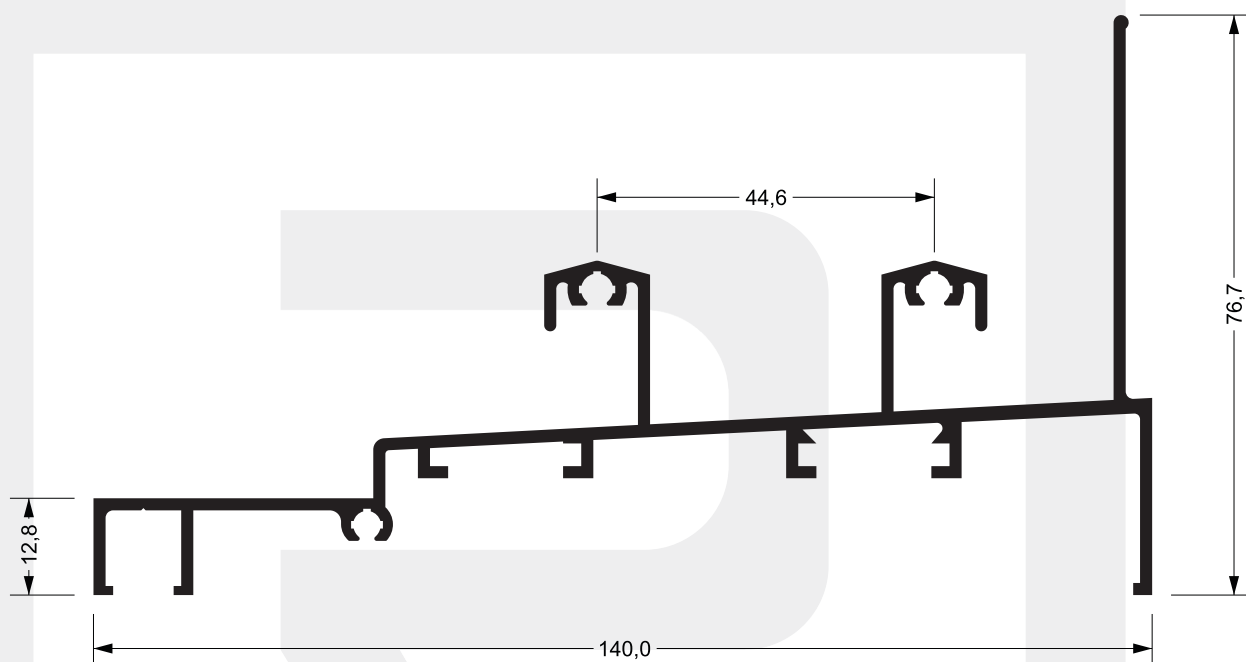

MN-030  
1,639 kg/m



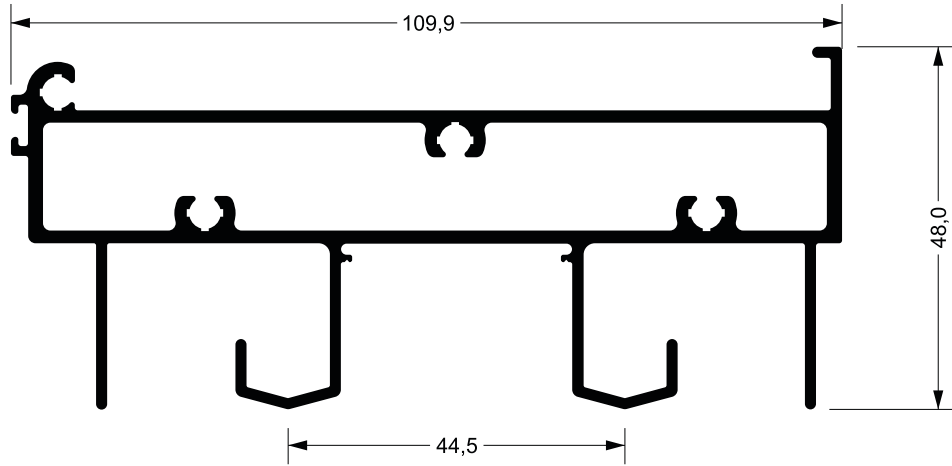

**RAL-044/SB**  
1,750 kg/m

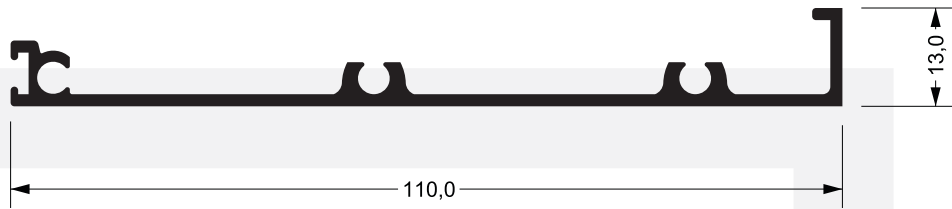

**MN-002**  
0,669 kg/m



**RAL-858**  
0,746 kg/m

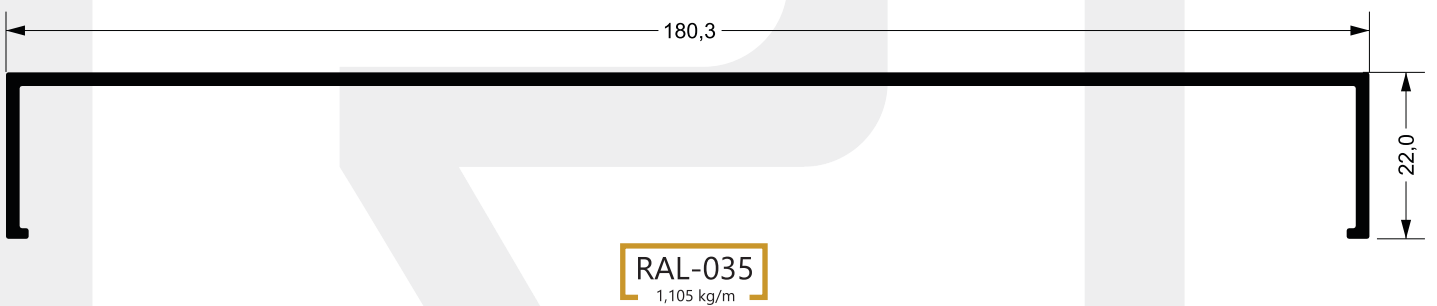
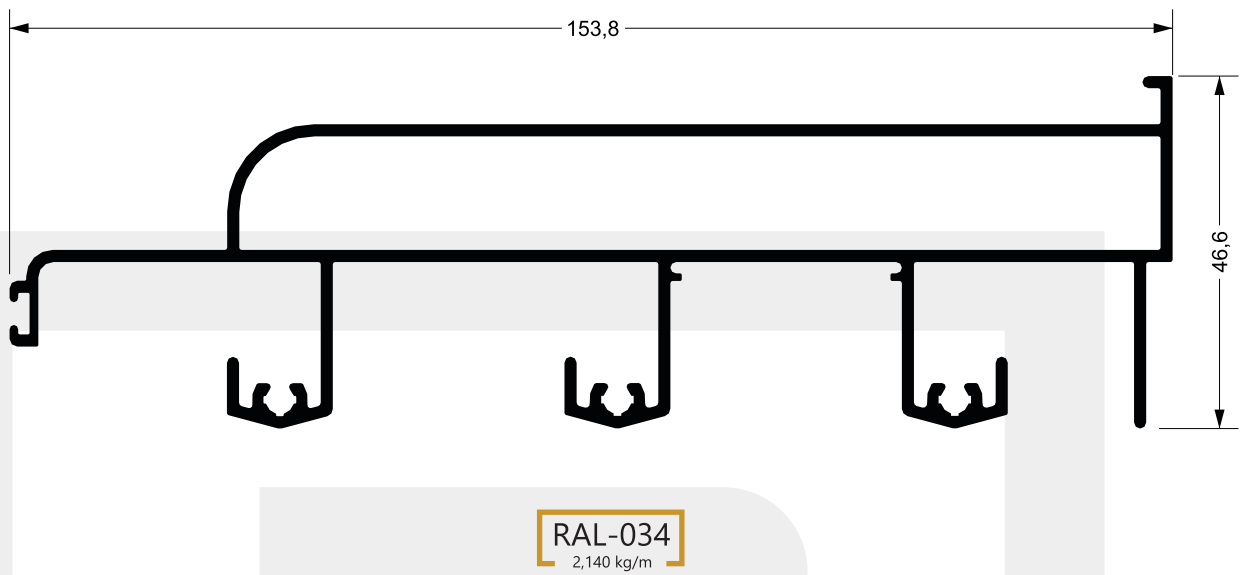
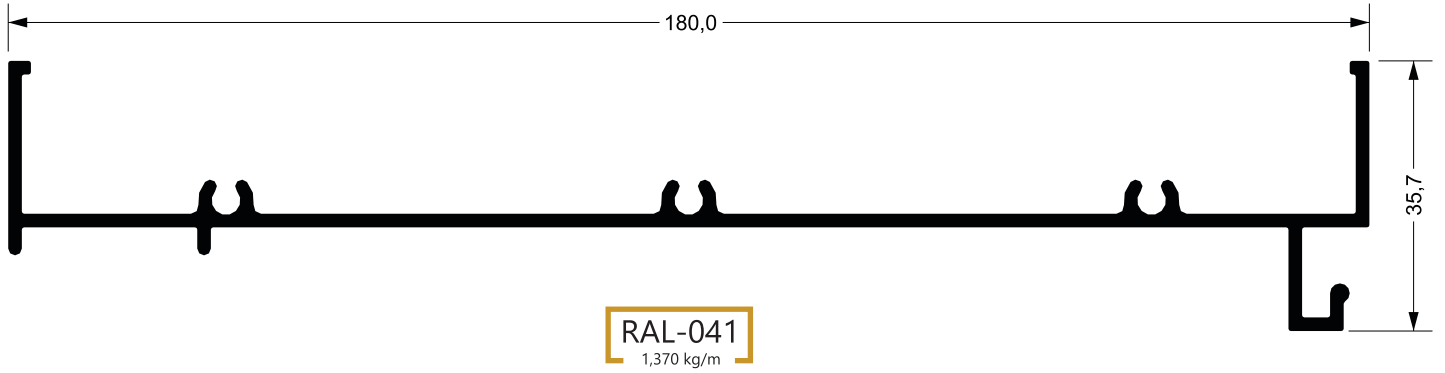

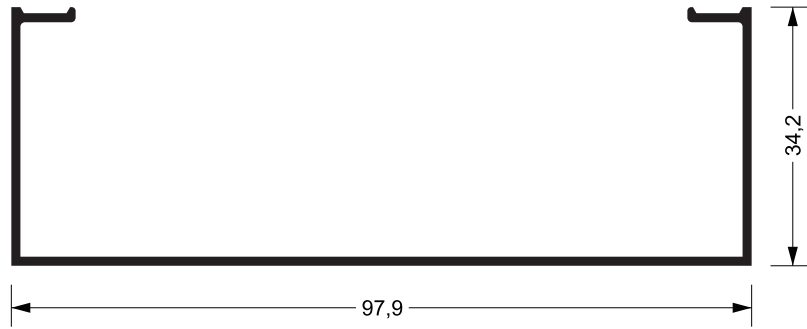

**MN-050**  
0,734 kg/m

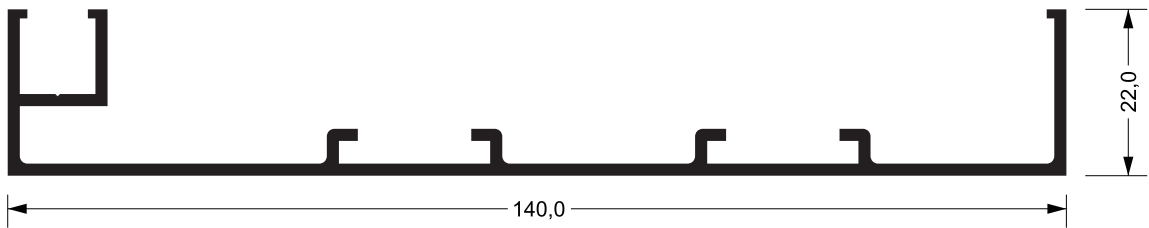

**MN-003**  
1,037 kg/m

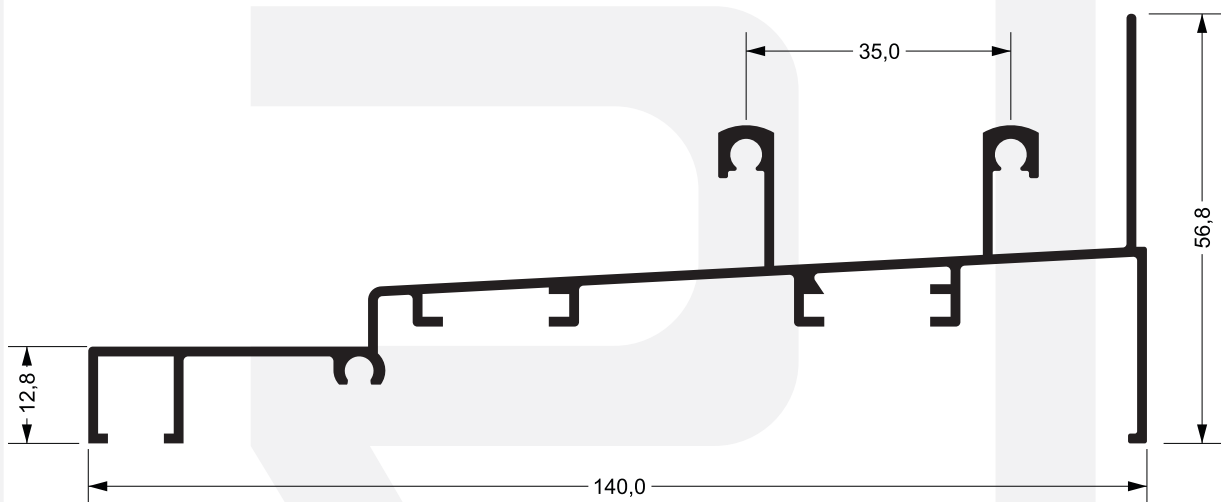

**MN-010**  
1,420 kg/m

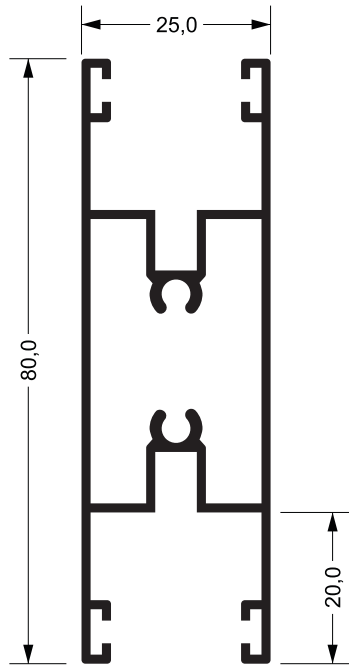

**MN-027**  
0,189 kg/m

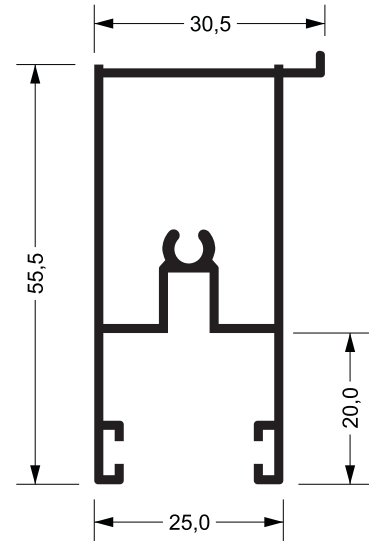

**MN-007**  
0,707 kg/m

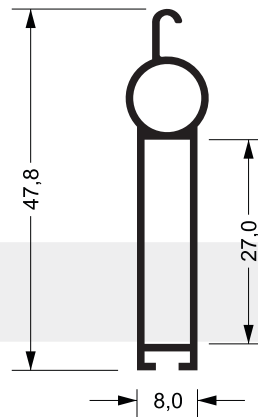

**MN-055**  
0,382 kg/m

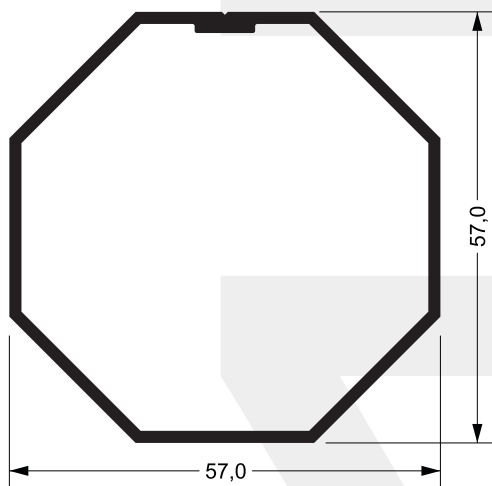

**MN-015**  
0,790 kg/m

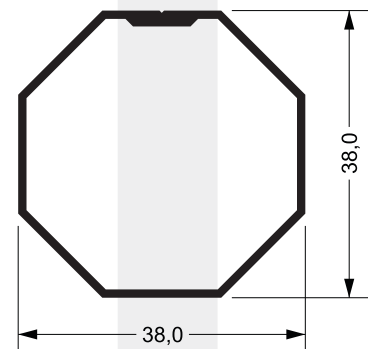

**DS-238**  
0,500 kg/m

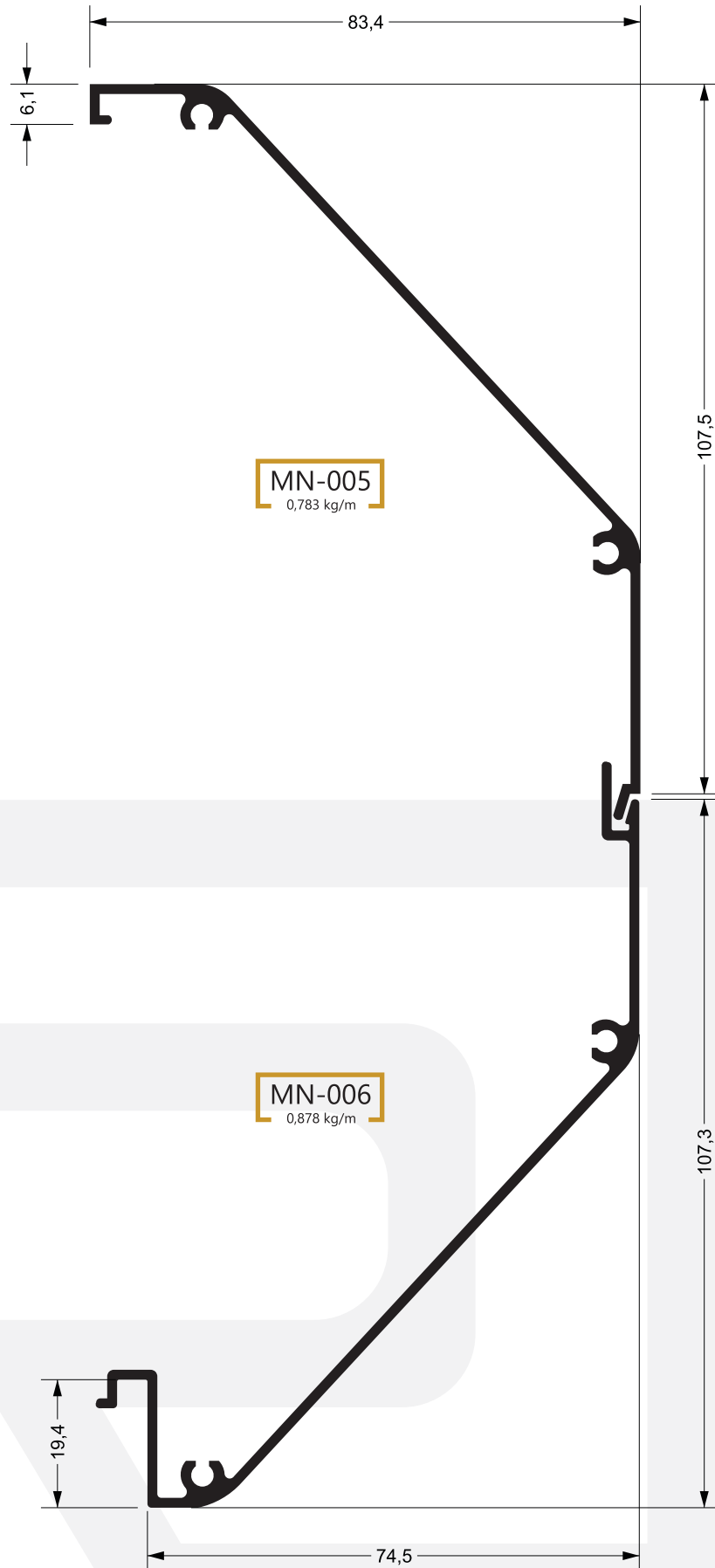

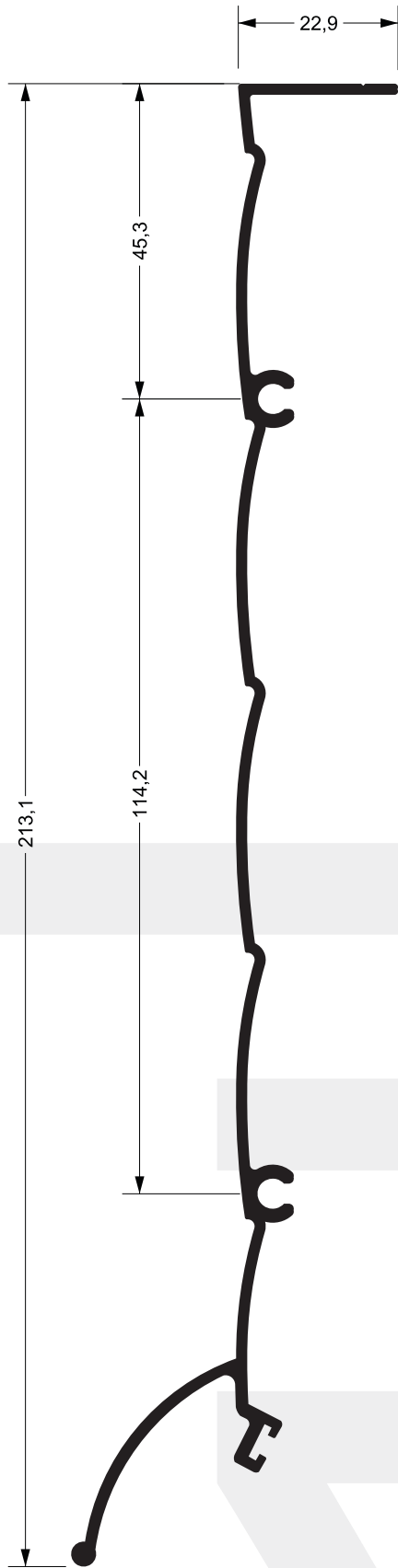

**MN-039**  
1,356 kg/m

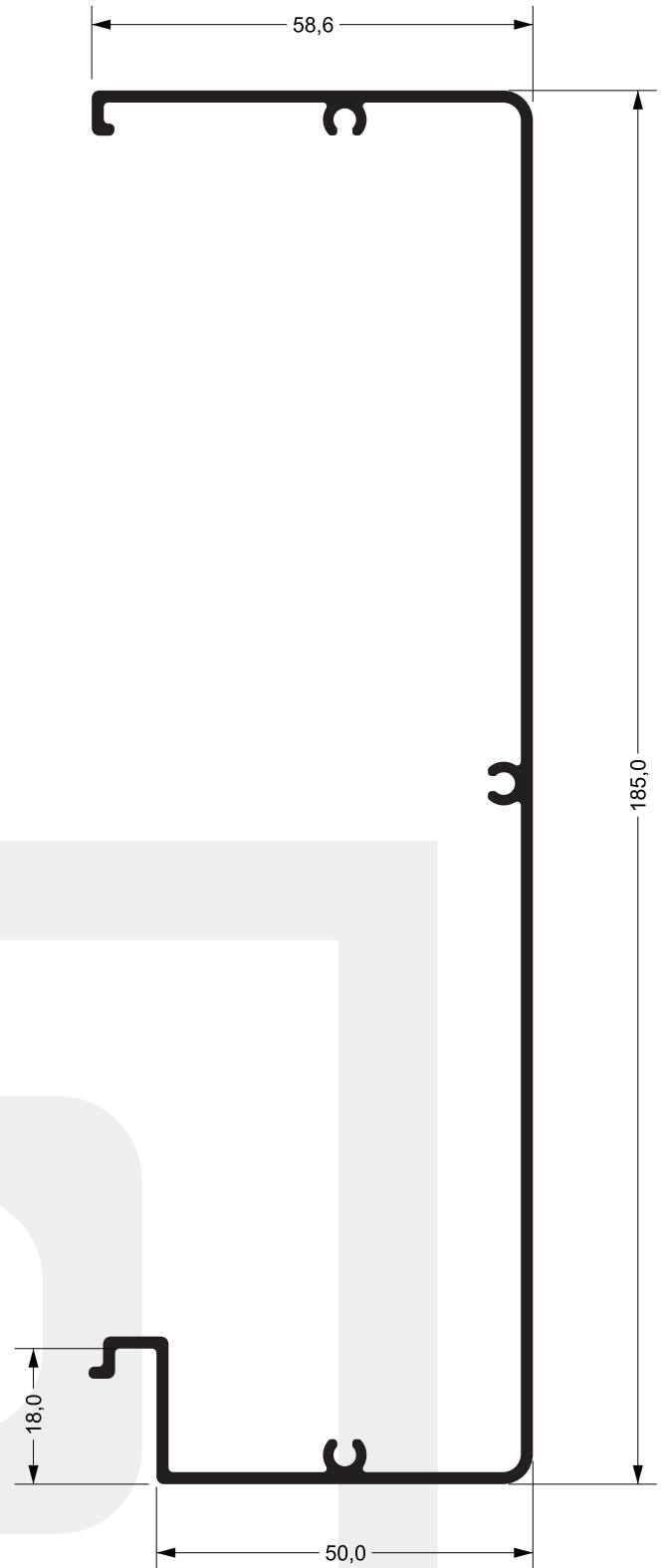

**MN-032**  
1,286 kg/m

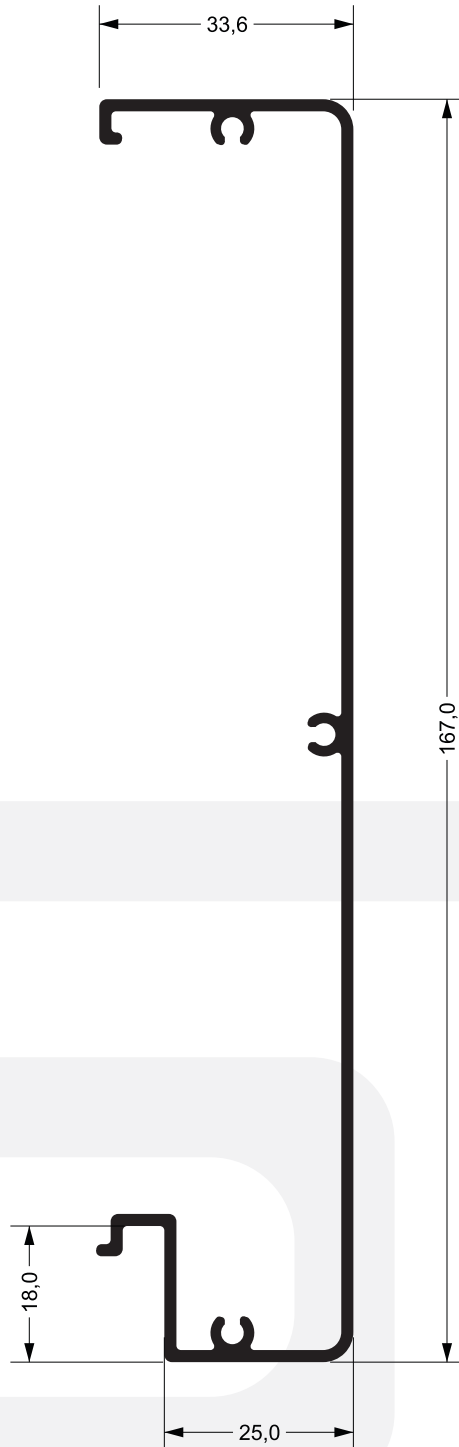

**MN-031**  
1,009 kg/m

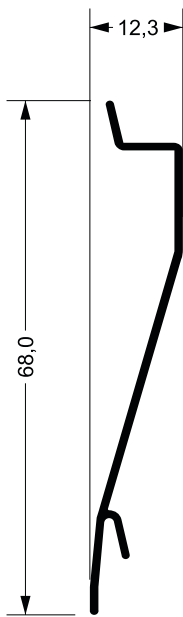

**VZ-051**  
0,270 kg/m

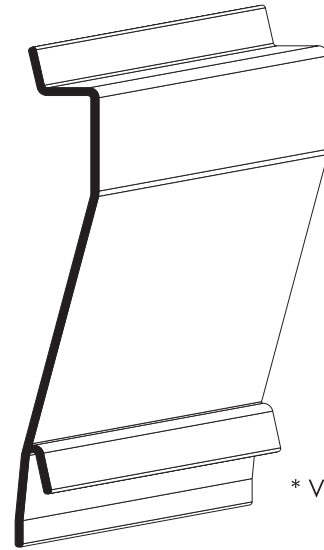

**US-294**  
0,260 kg/m

\* VENTILADA

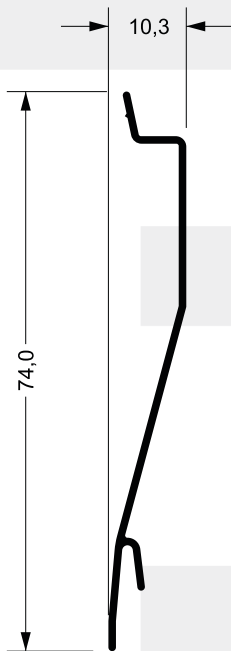

**Z-201**  
0,275 kg/m

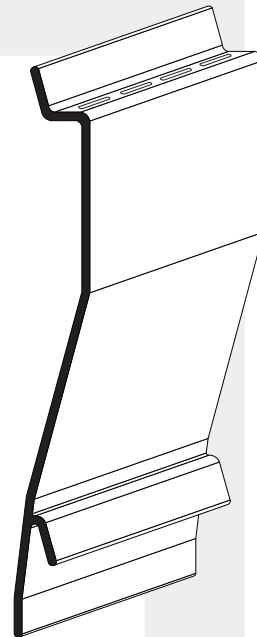

**Z-201V**  
0,260 kg/m

\* VENTILADA



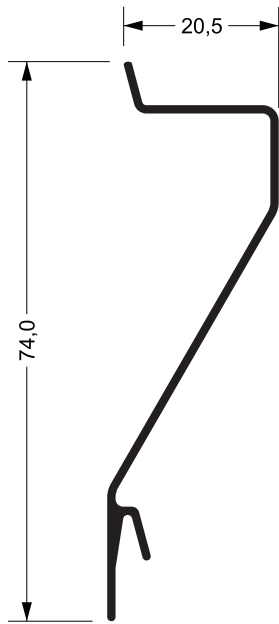

**VZ-006**  
0,560 kg/m

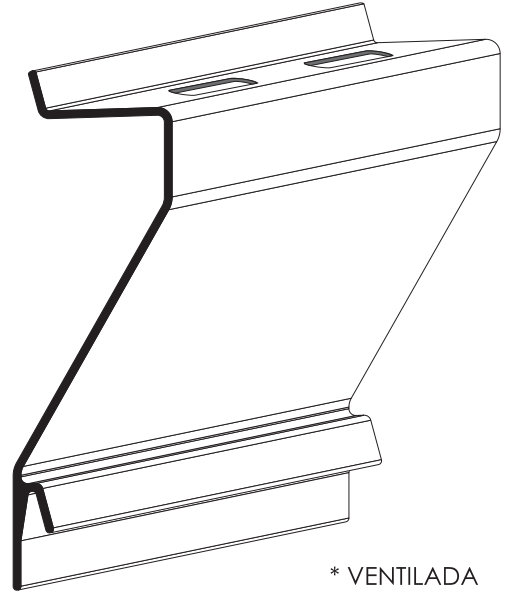

**US-285**  
0,560 kg/m

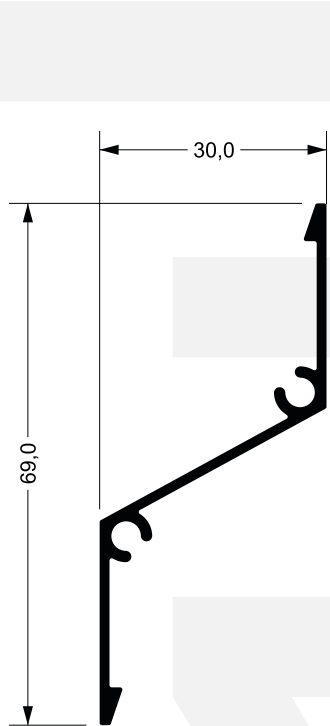

**VZ-060**  
0,394 kg/m

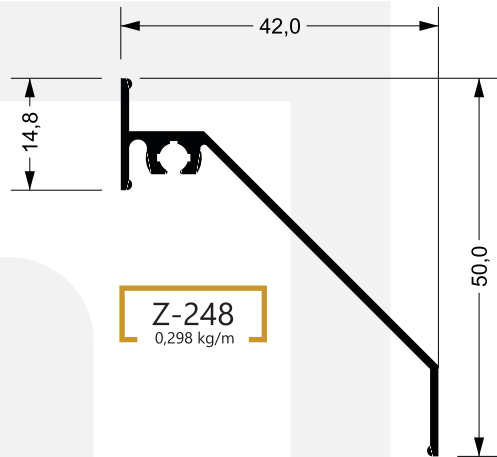

**Z-248**  
0,298 kg/m

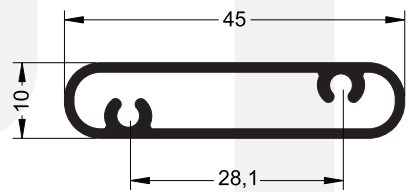

**RAL-004**  
0,392 kg/m

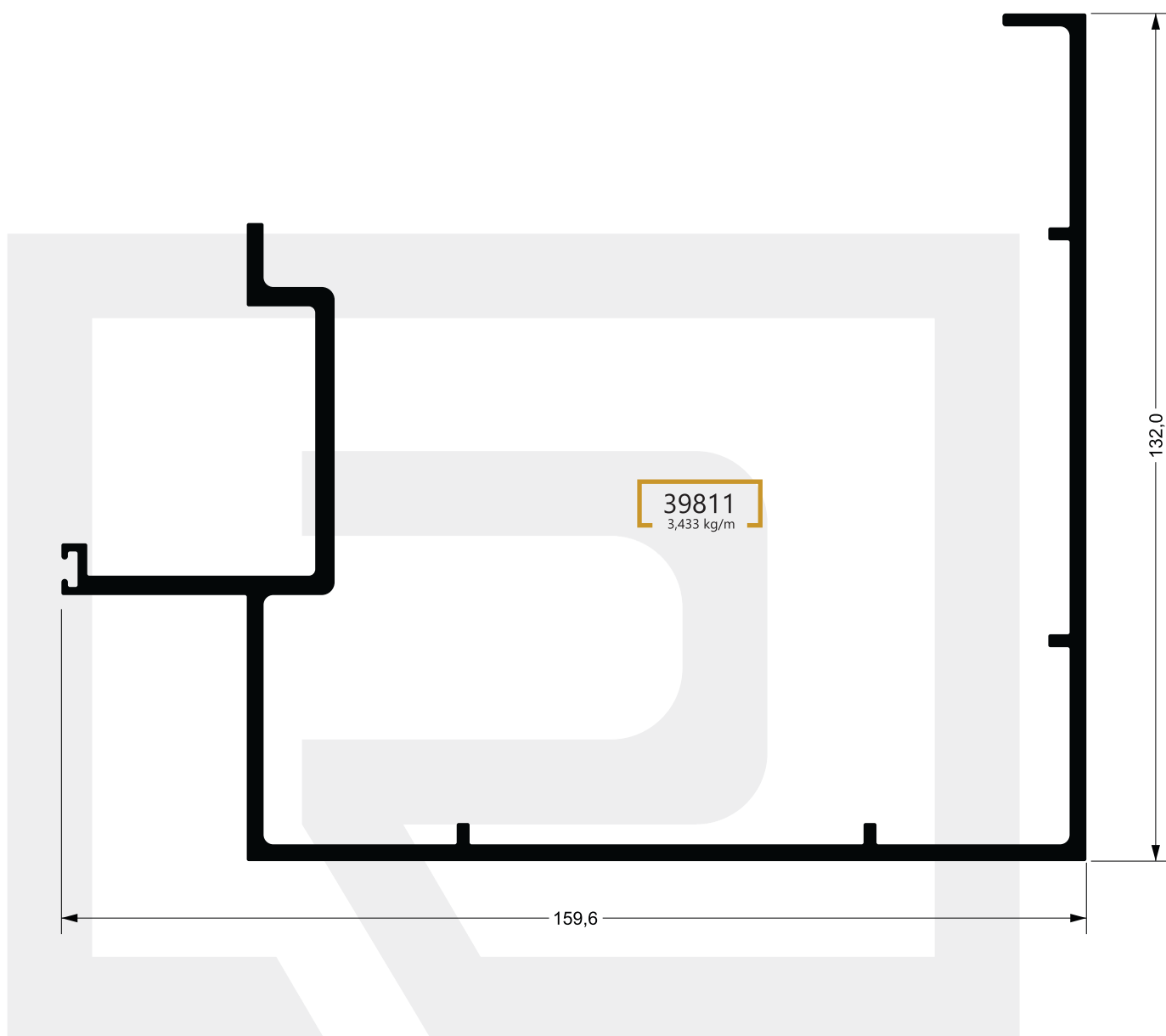
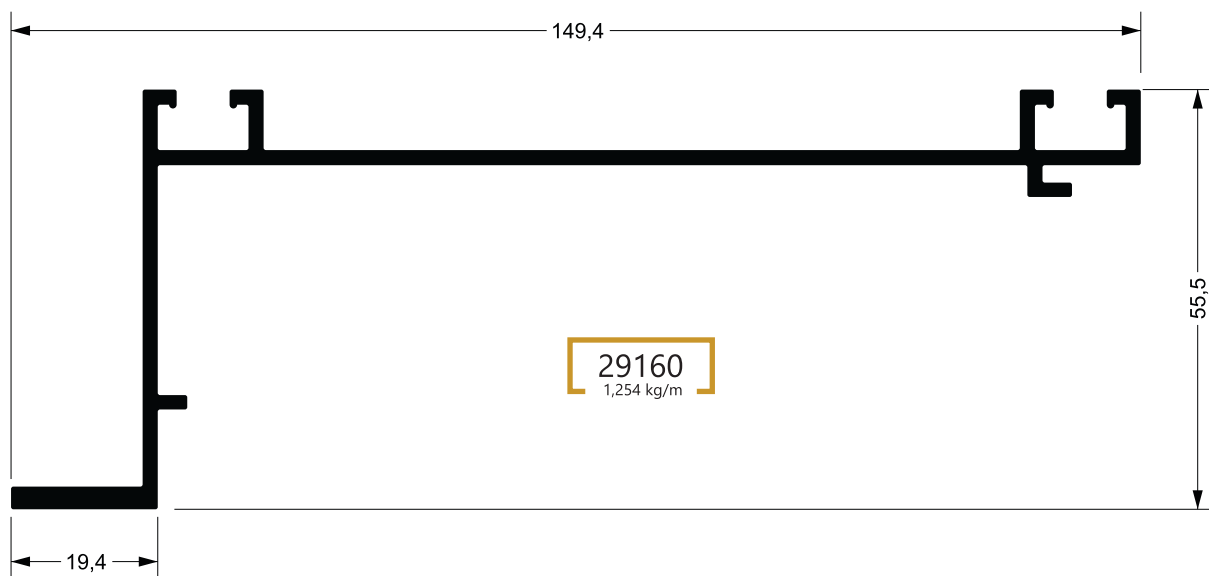



**raltex**  
PERFIS DE ALUMÍNIO

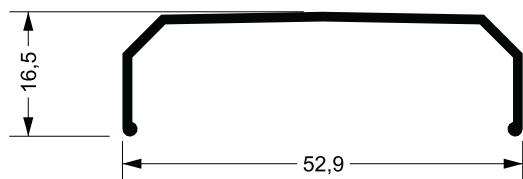

**U-498**  
0,285 kg/m

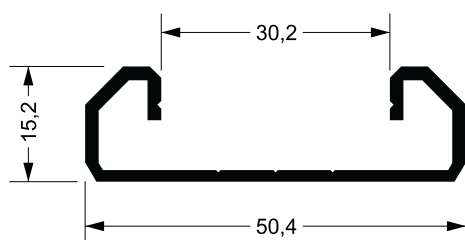

**U-497**  
0,570 kg/m

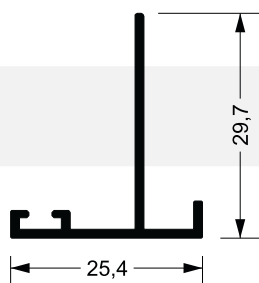

**T-214**  
0,200 kg/m

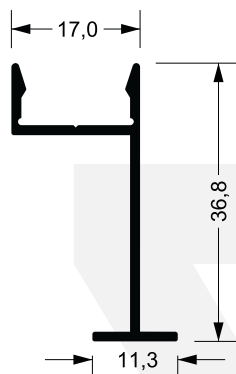

**50018**  
0,263 kg/m

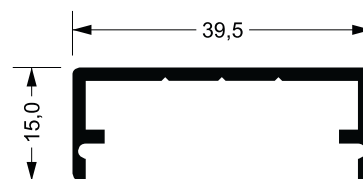

**U-496**  
0,380 kg/m

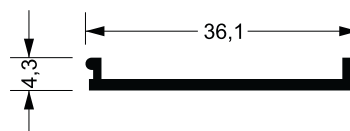

**U-495**  
0,171 kg/m

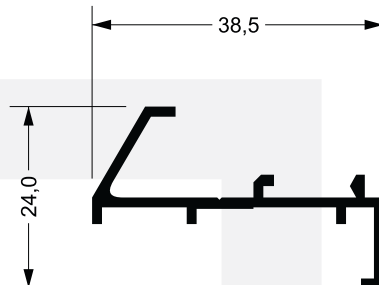

**Z-063**  
0,324 kg/m

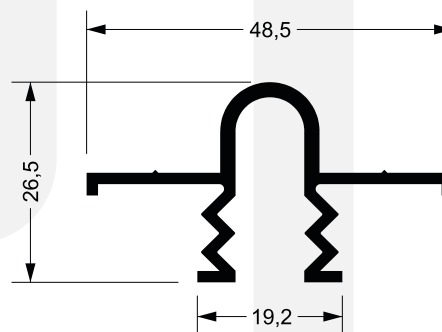

**E-364**  
0,393 kg/m

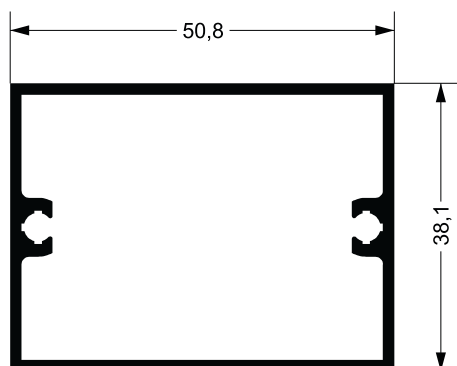

**D-103**  
0,779 kg/m

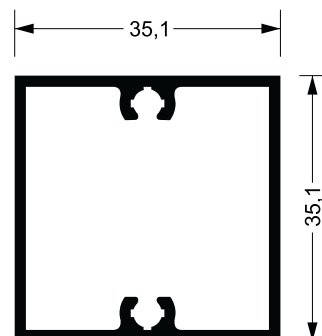

**D-081**  
0,610 kg/m

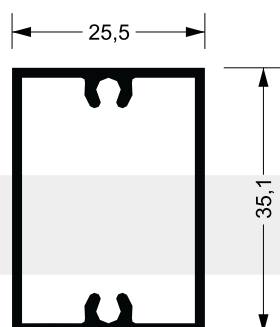

**D-055**  
0,510 kg/m

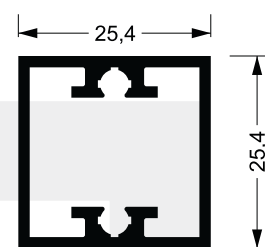

**D-080**  
0,524 kg/m

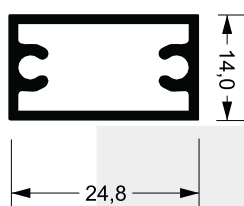

**D-082**  
0,342 kg/m

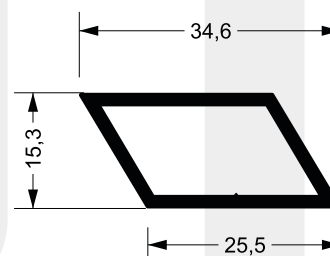

**RAL-286**  
0,265 kg/m



**raltex**  
PERFIS DE ALUMÍNIO

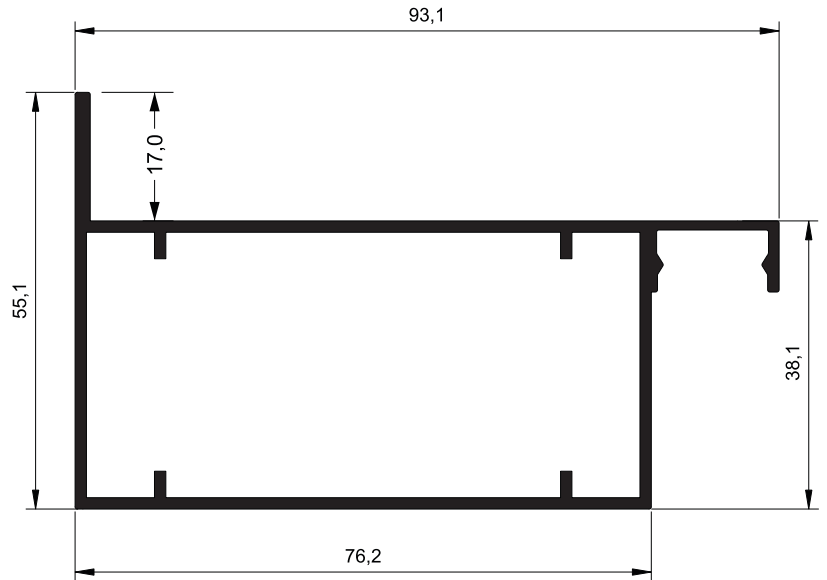
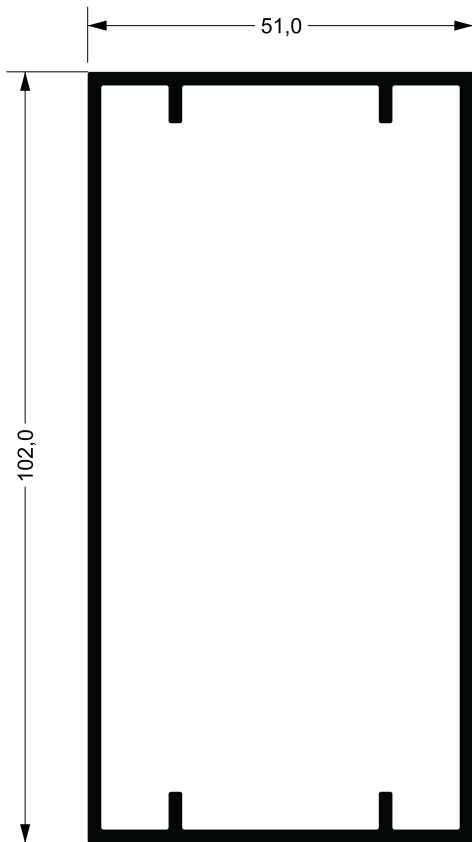

**RAL-501**  
1,176 kg/m

**78719**  
1,555 kg/m

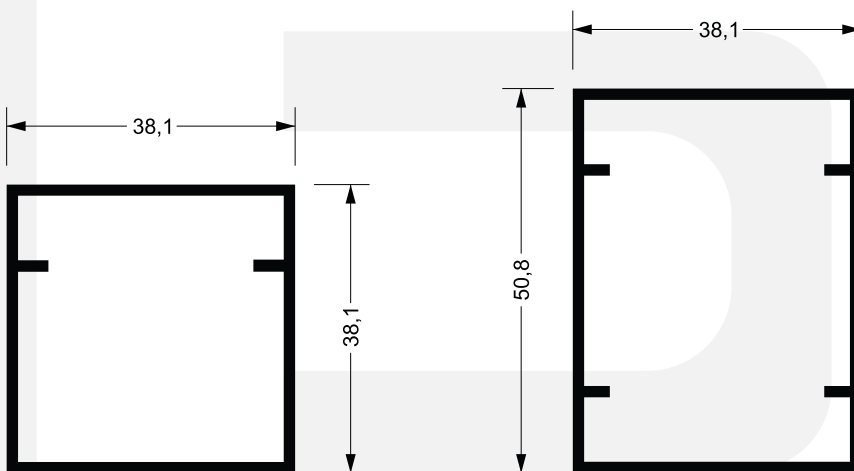

**D-102**  
0,627 kg/m

**D-078**  
0,720 kg/m

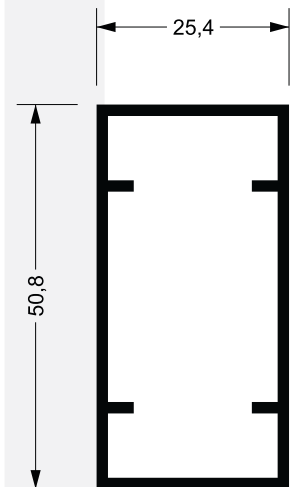

**D-079**  
0,576 kg/m

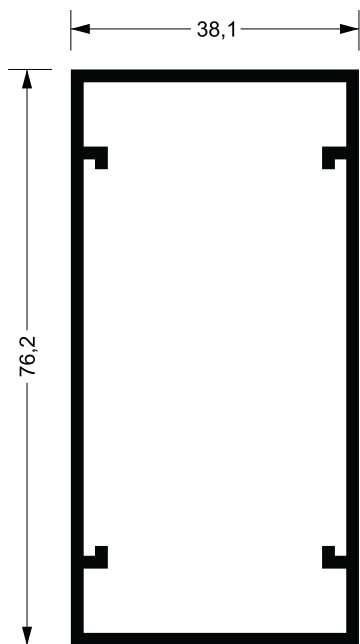

**D-069**  
1,053 kg/m

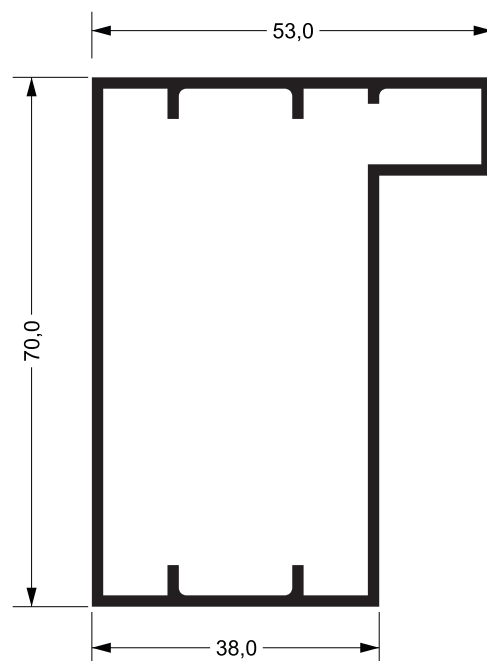

**PC-010**  
1,190 kg/m

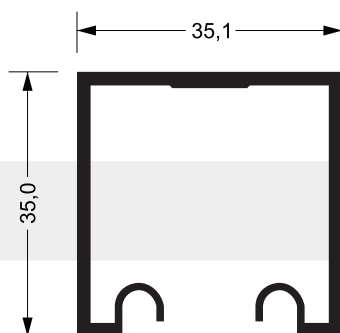

**U-1098**  
0,560 kg/m

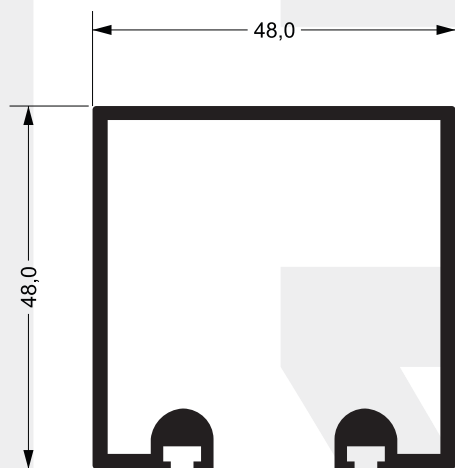

**U-1049**  
1,500 kg/m

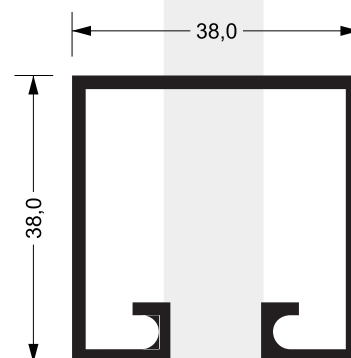

**U-990**  
0,650 kg/m



**raltex**  
PERFIS DE ALUMÍNIO

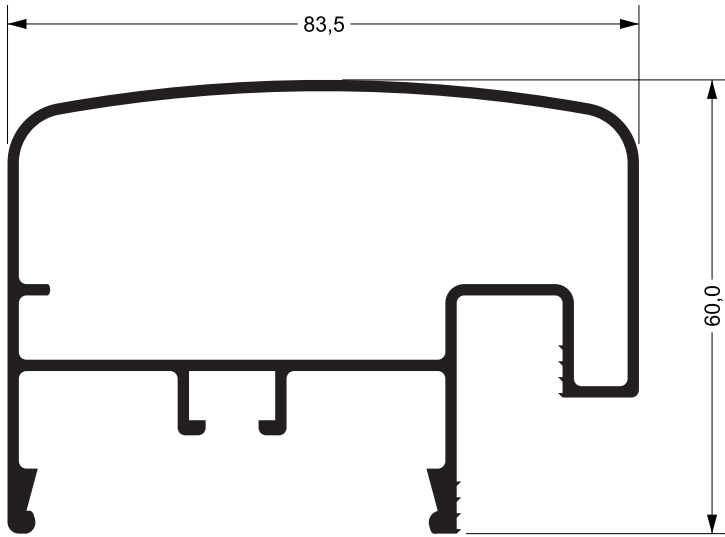

**CG-083**  
1,321 kg/m

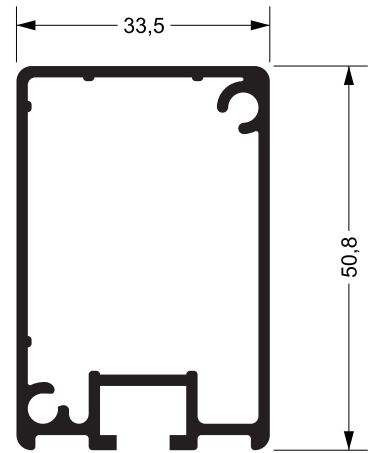

**CG-077**  
0,488 kg/m

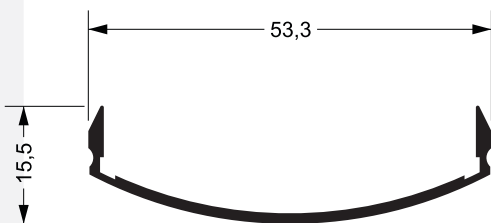

**CG-074**  
0,242 kg/m

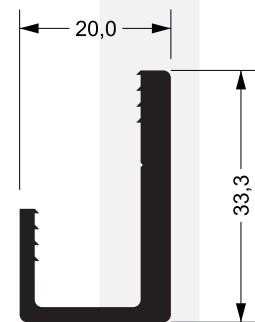

**CG-075**  
0,519 kg/m

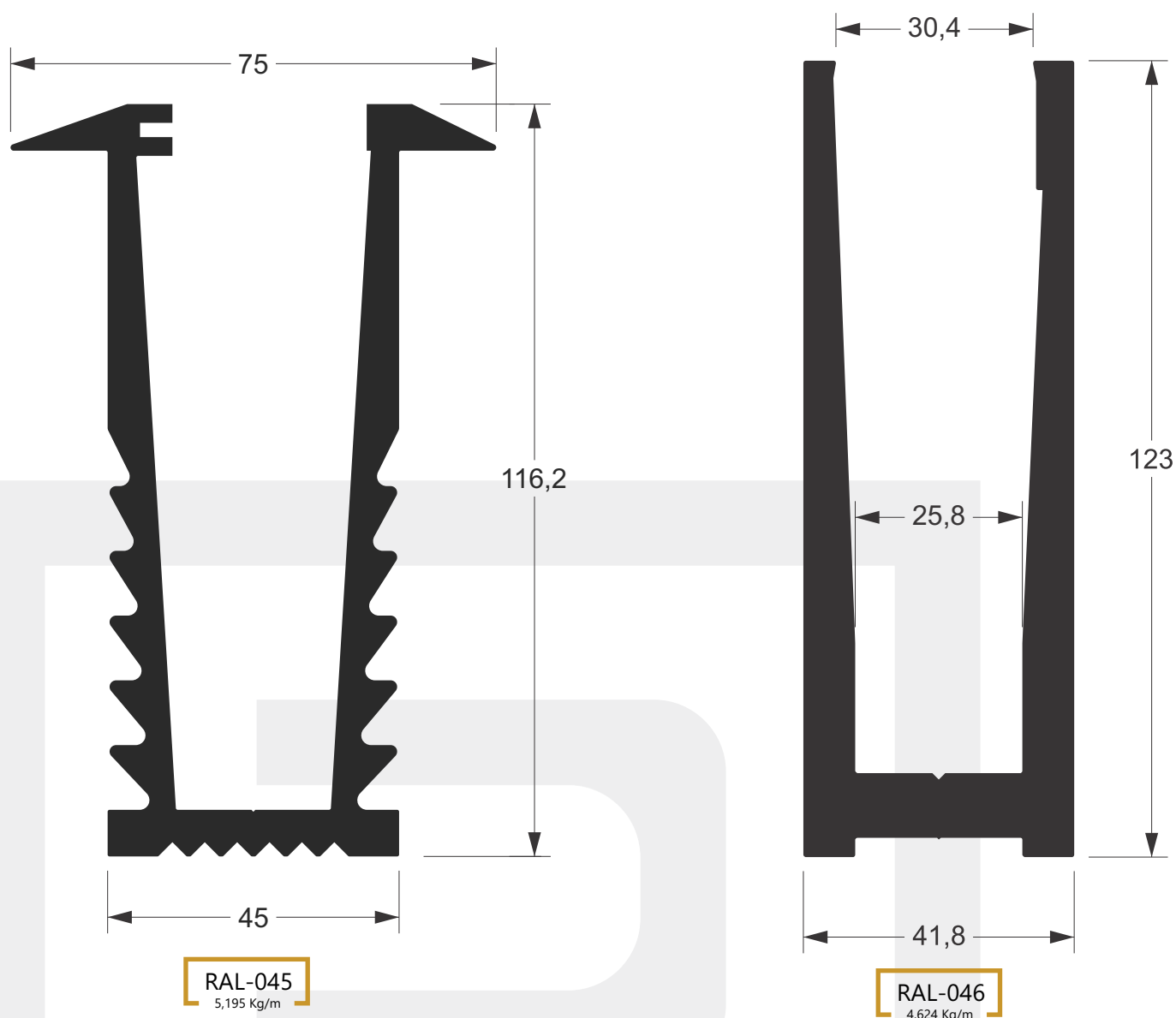



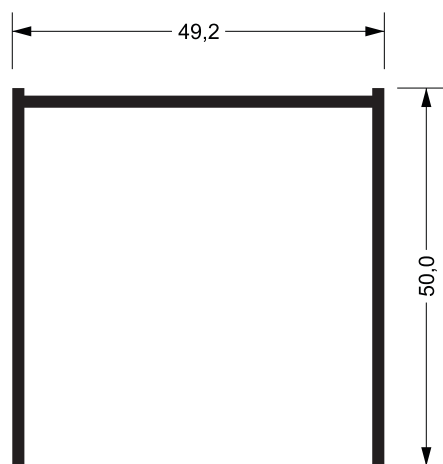

**39498**  
0,636 kg/m

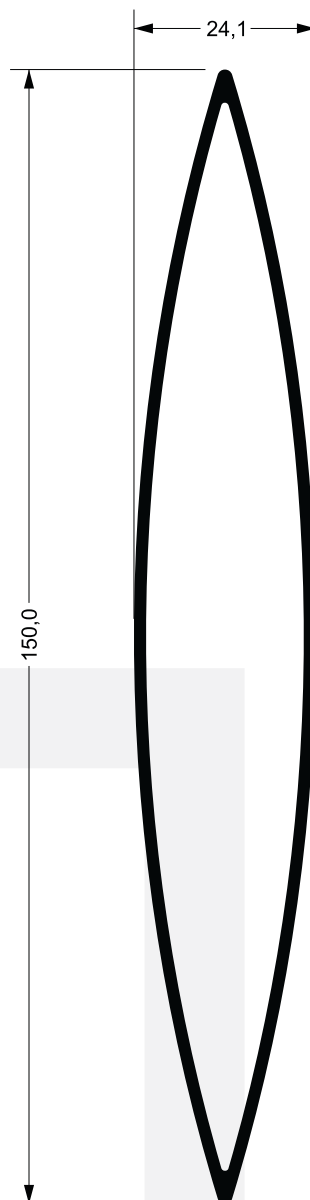

**D-053**  
1,300 kg/m

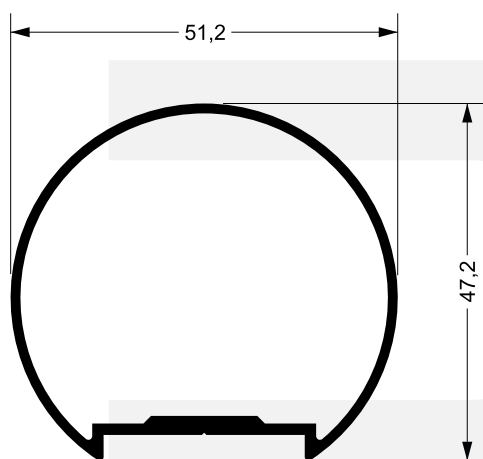

**D-094**  
0,686 kg/m

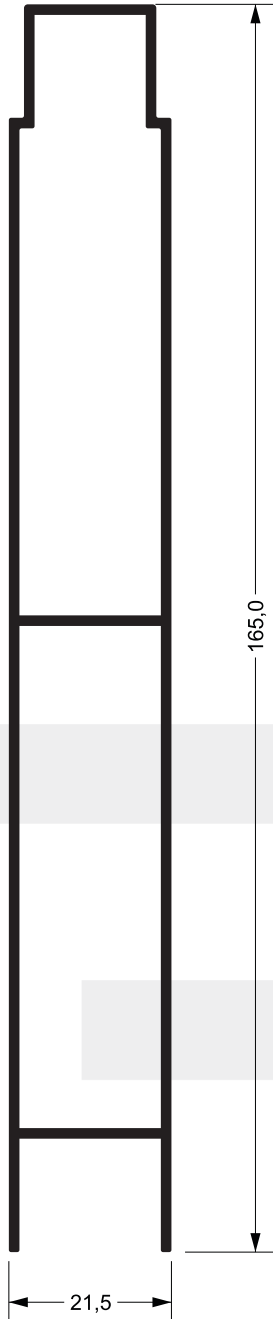

**CX-189**  
1,600 kg/m

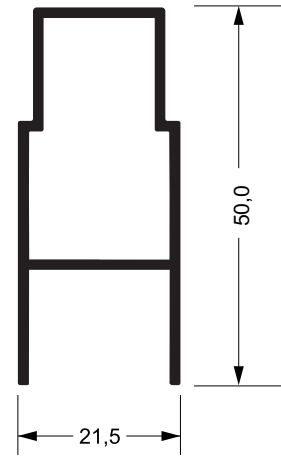

**CX-188**  
0,629 kg/m

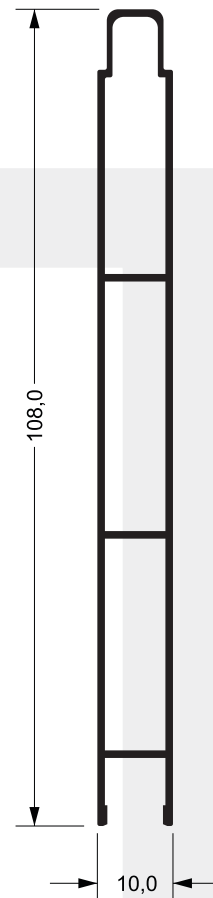

**CX-185**  
0,841 kg/m

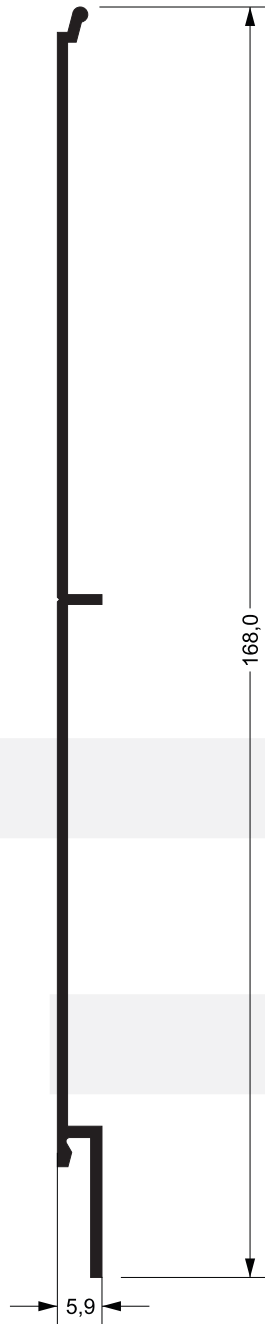

**Y-335**  
0,792 kg/m

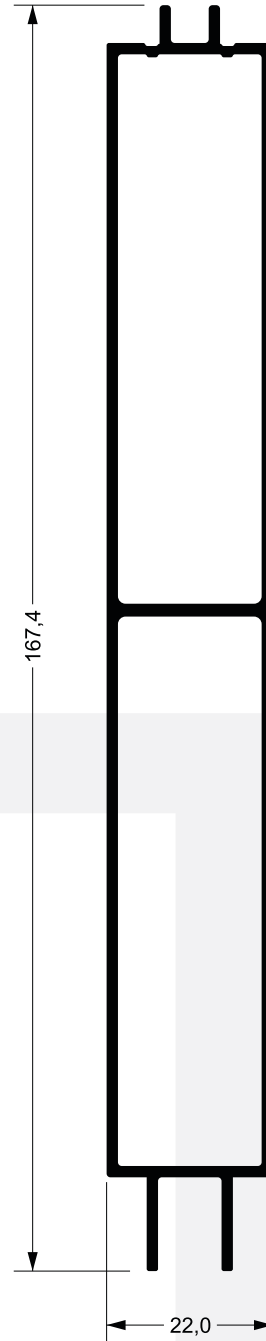

**78-1740D**  
1,800 kg/m

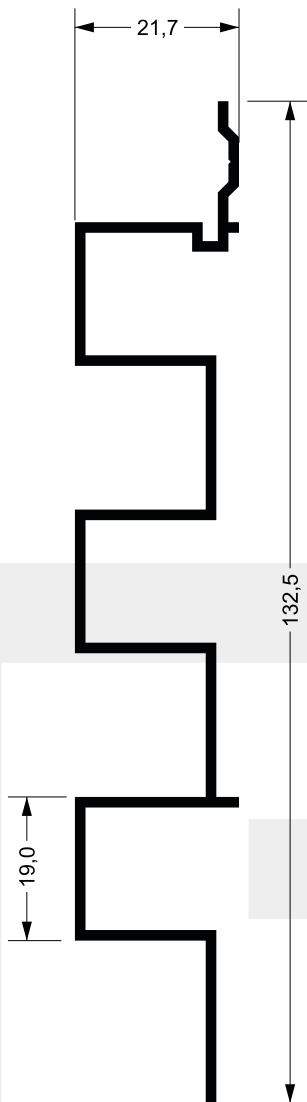

**RAL-689**  
0,990 kg/m

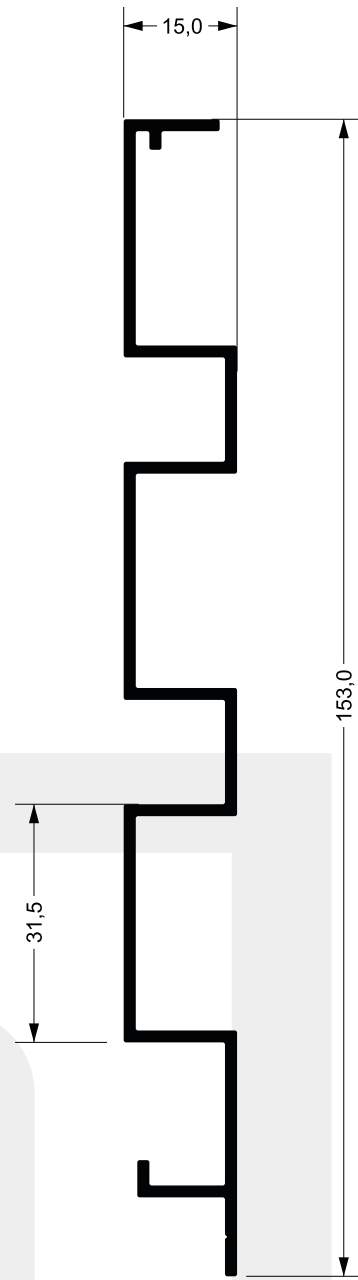

**RAL-782**  
0,951 kg/m

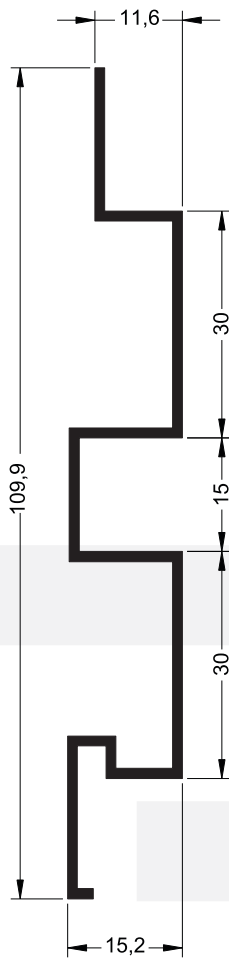

**RAL-699**  
0,653kg/m

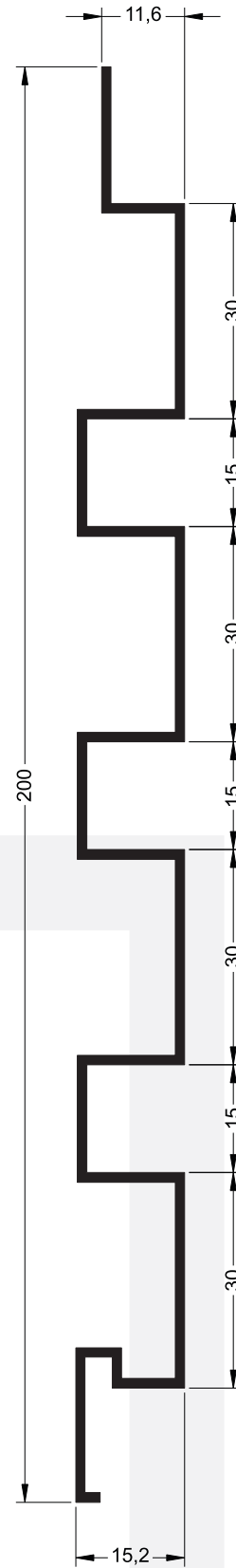

**RAL-977**  
1,035 kg/m

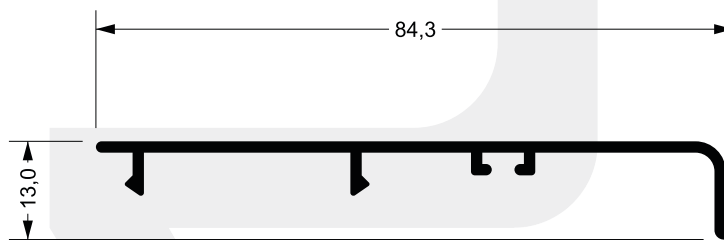
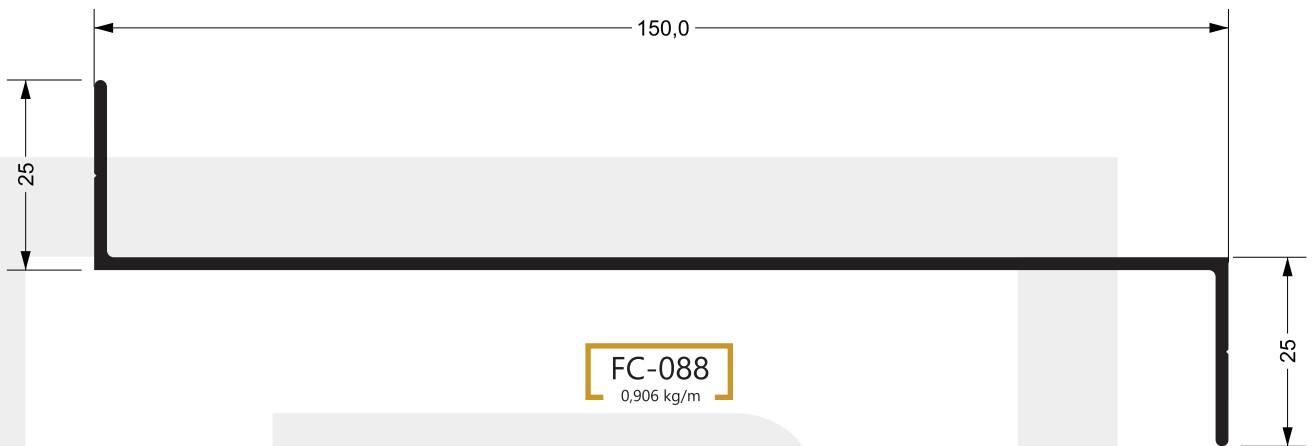
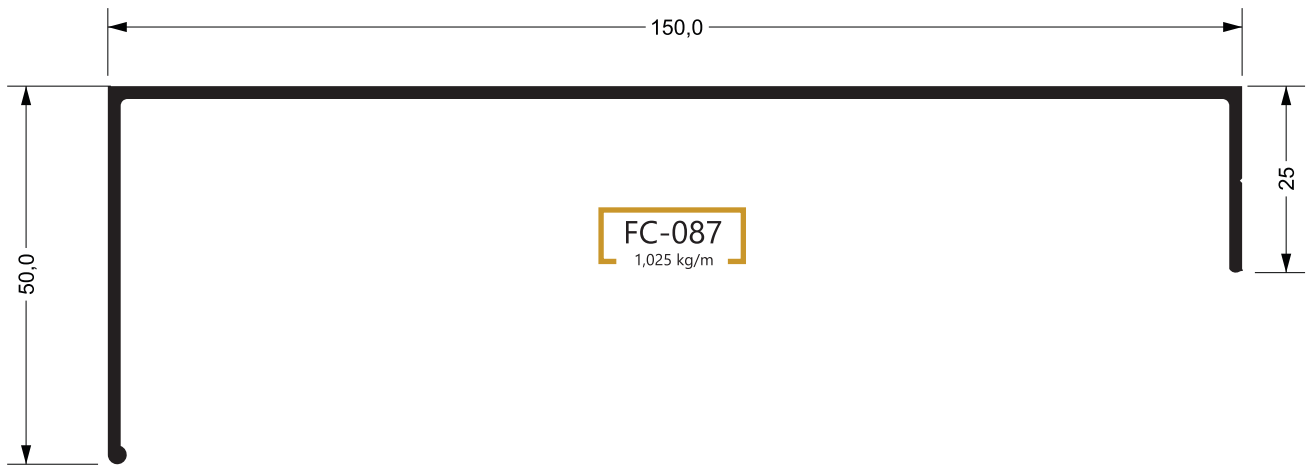

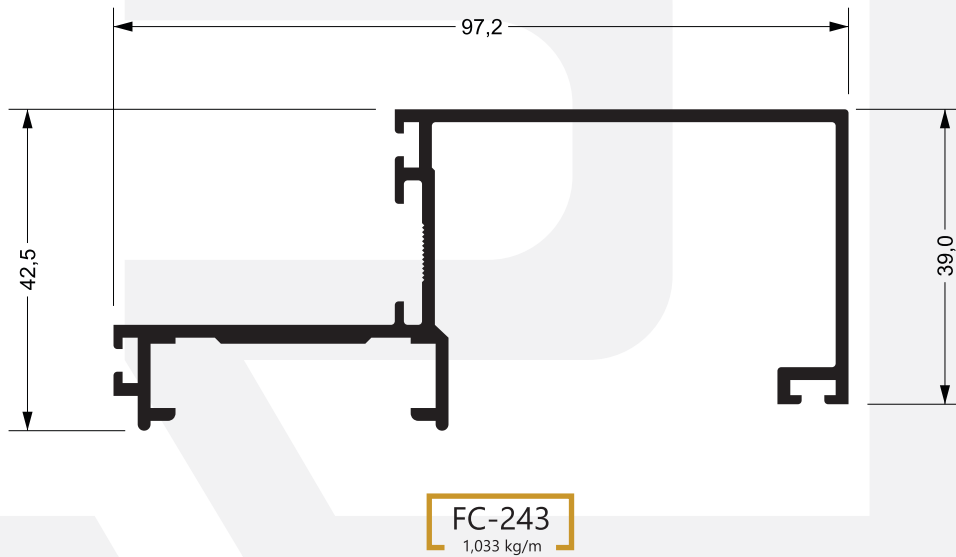
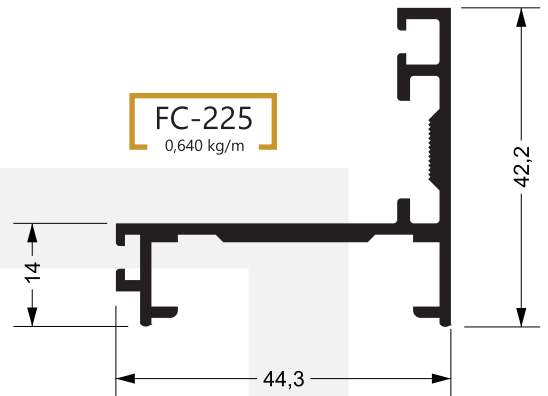
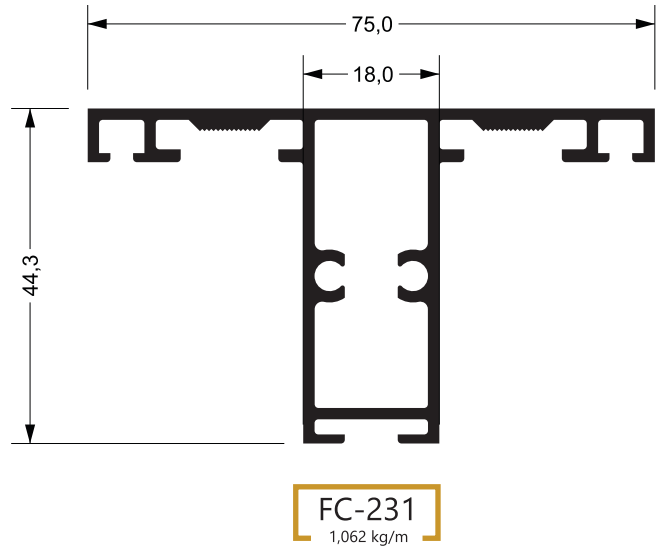
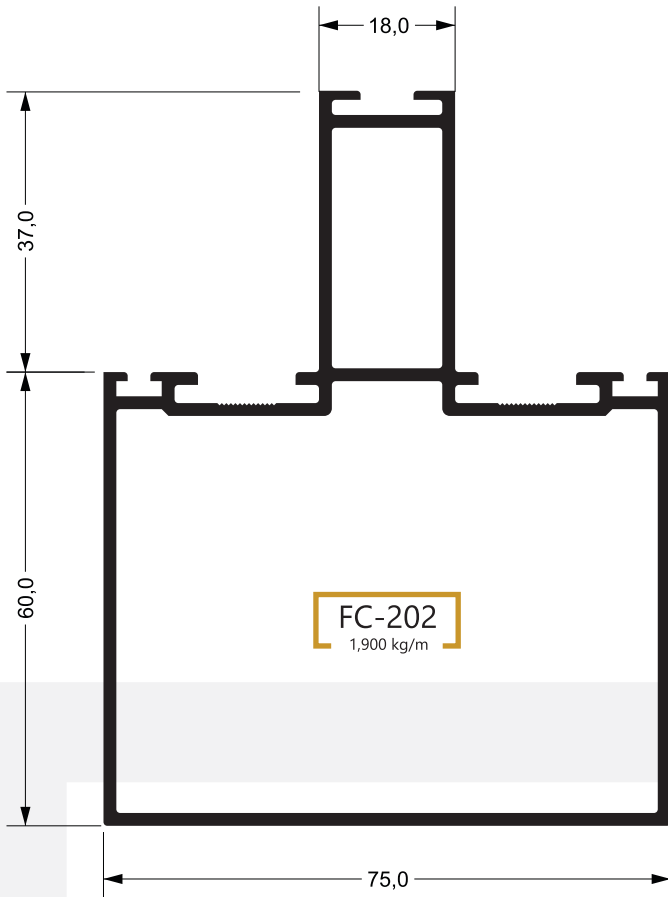

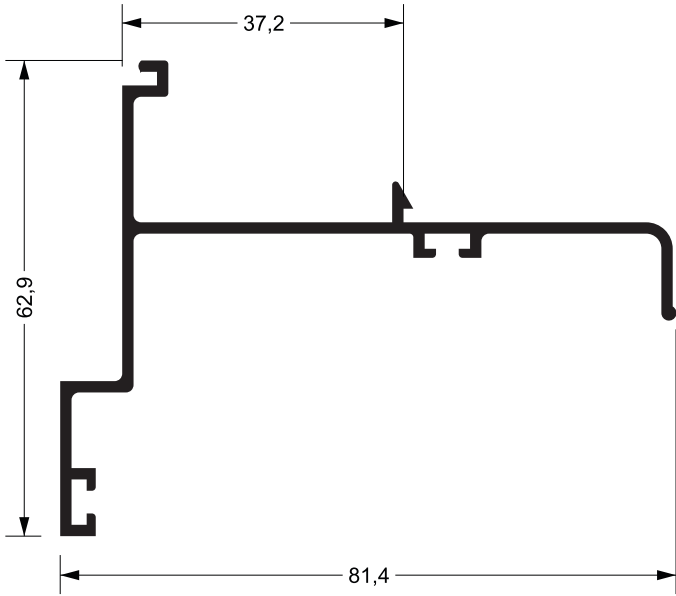

**FC-226**  
0,749 kg/m

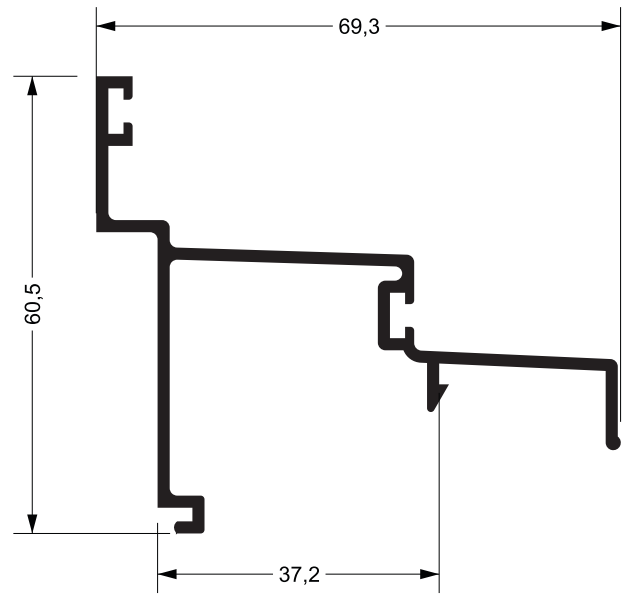

**FC-222**  
0,759 kg/m

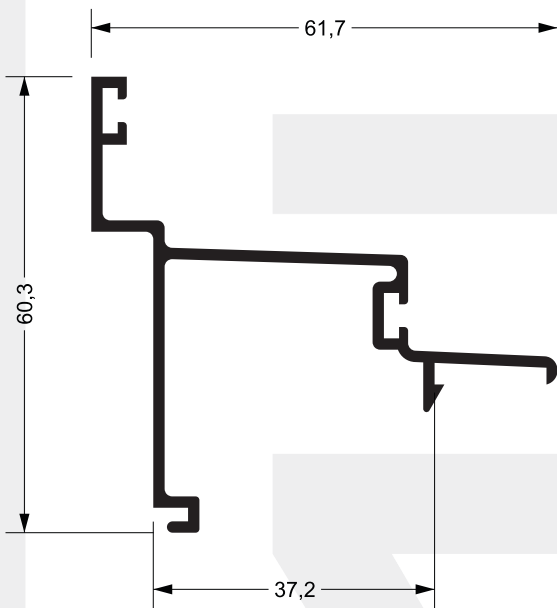

**FC-227**  
0,740 kg/m

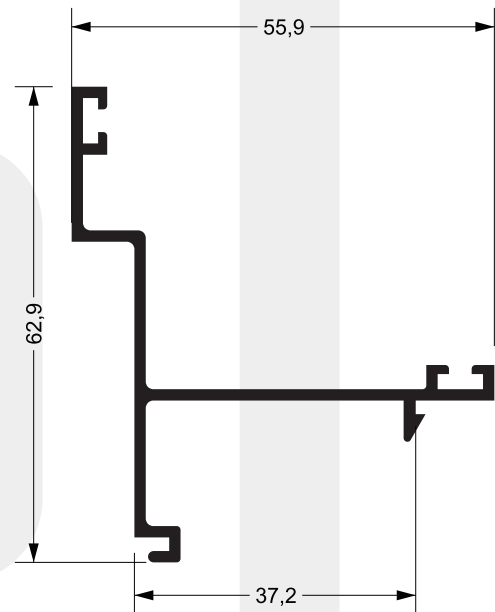

**FC-249**  
0,604 kg/m



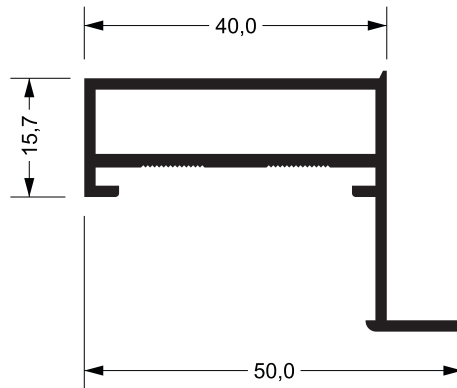

**FC-228**  
0,600 kg/m

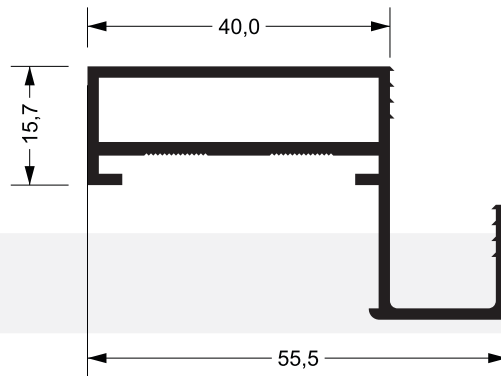

**FC-293**  
0,651 kg/m

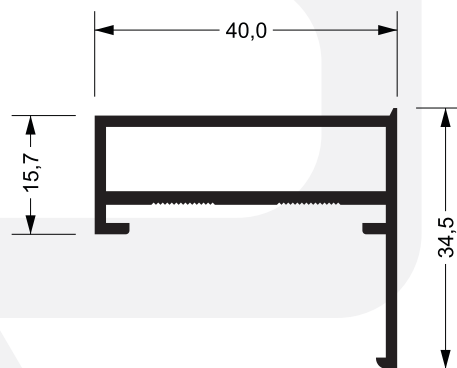

**FC-261**  
0,556 kg/m

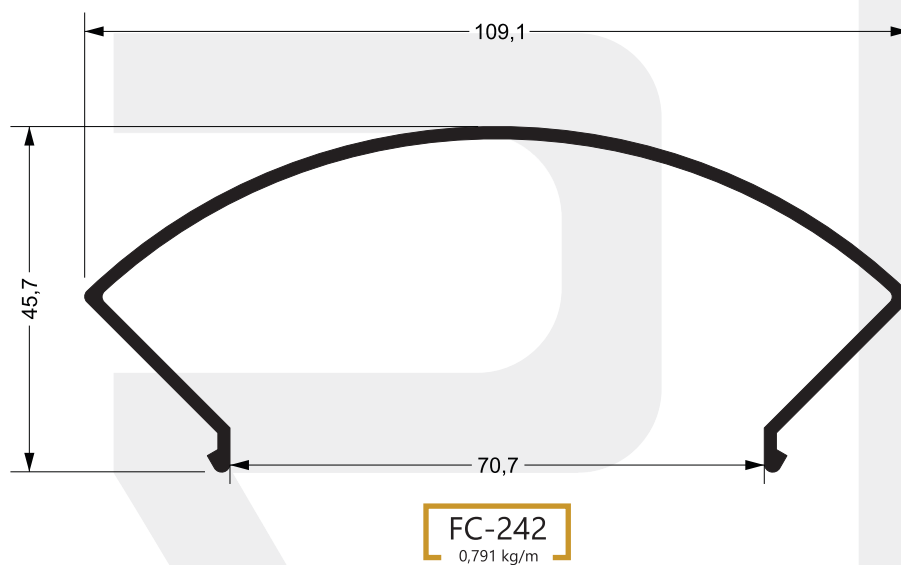
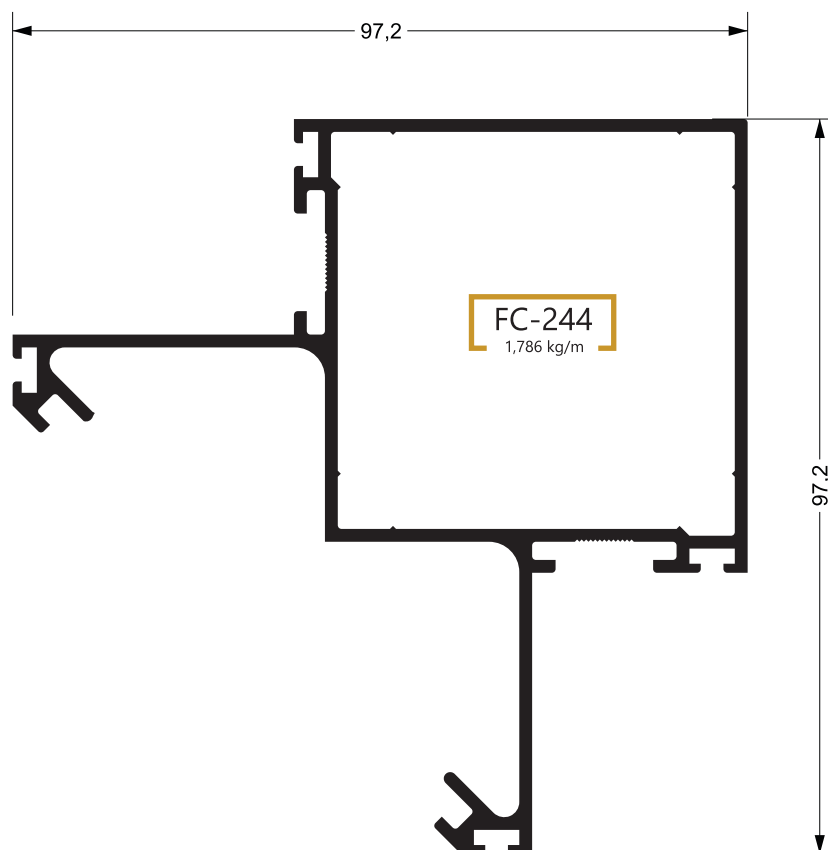

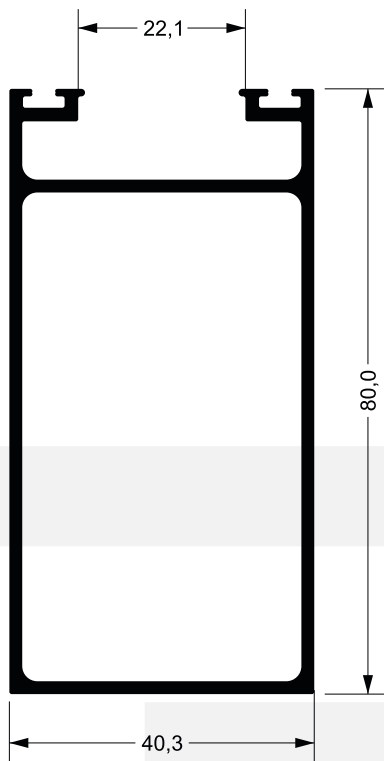

**A-072**  
1,280 kg/m

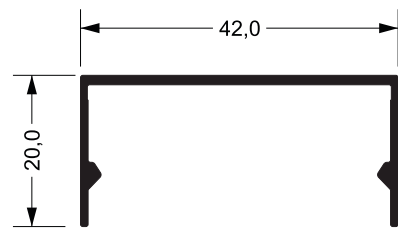

**U-621**  
0,265 kg/m

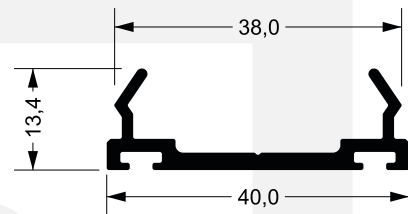

**U-615**  
0,434 kg/m

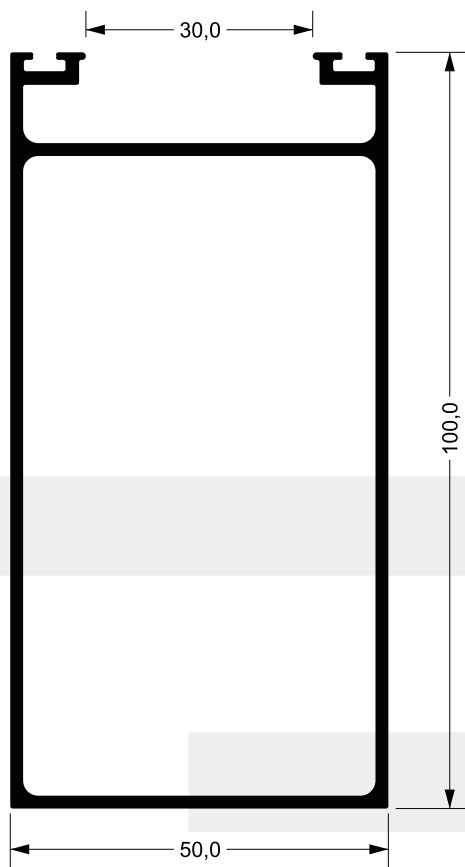

**A-096**  
1,822 kg/m

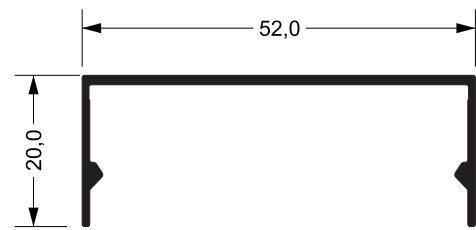

**U-877**  
0,350 kg/m

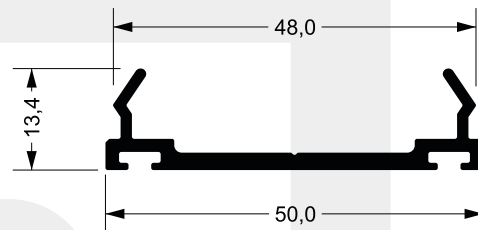

**U-878**  
0,434 kg/m

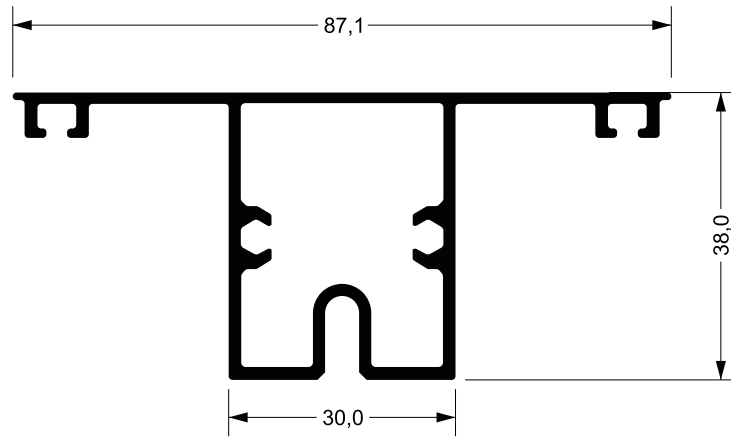

RA-204  
1,046 kg/m

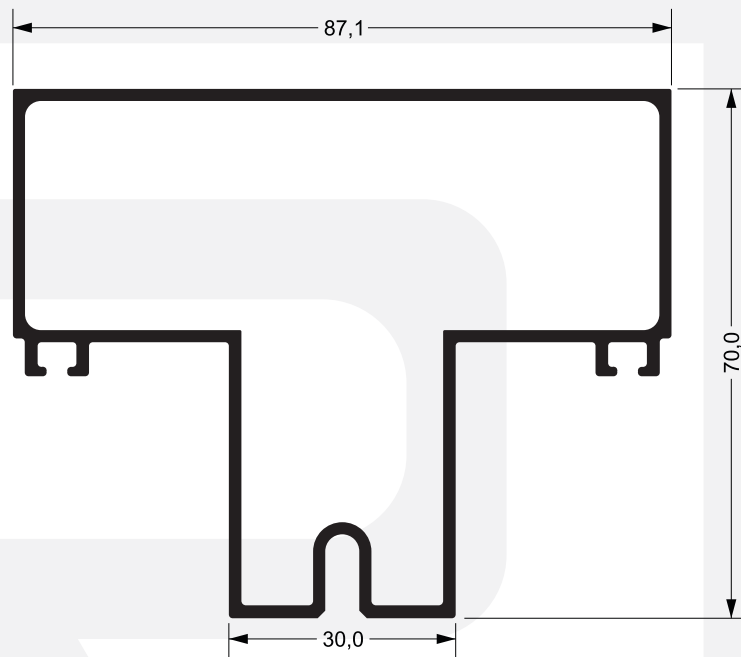

RA-400  
1,870 kg/m

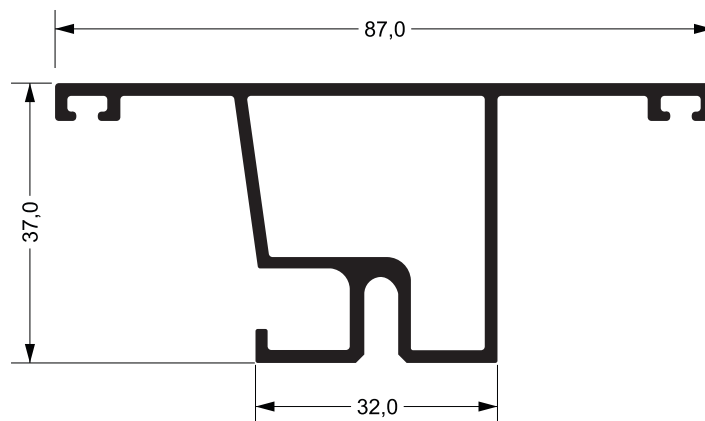

RA-211  
0,998 kg/m

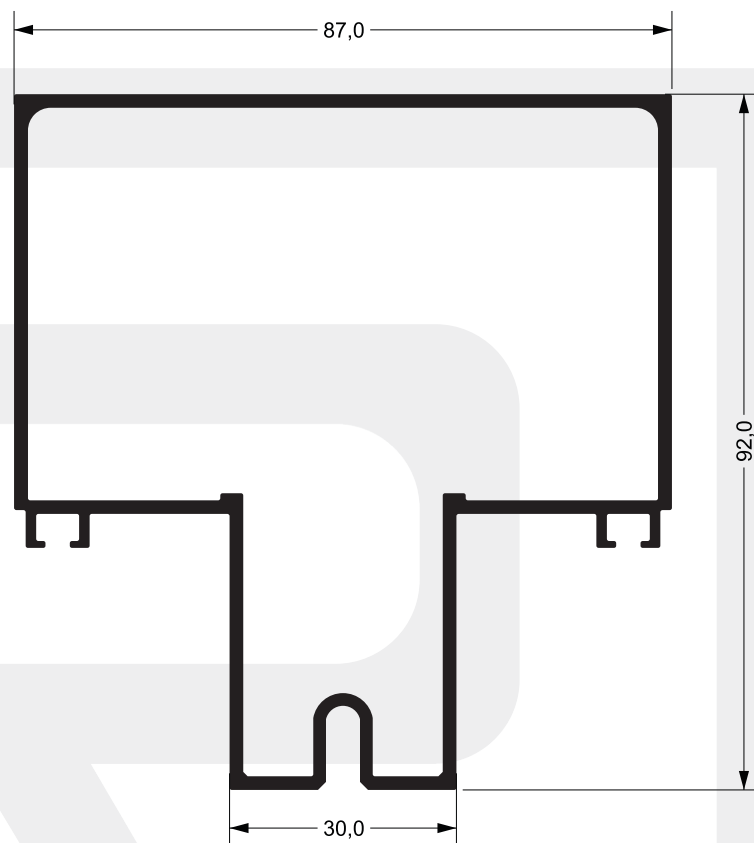

RA-200  
1,968 kg/m

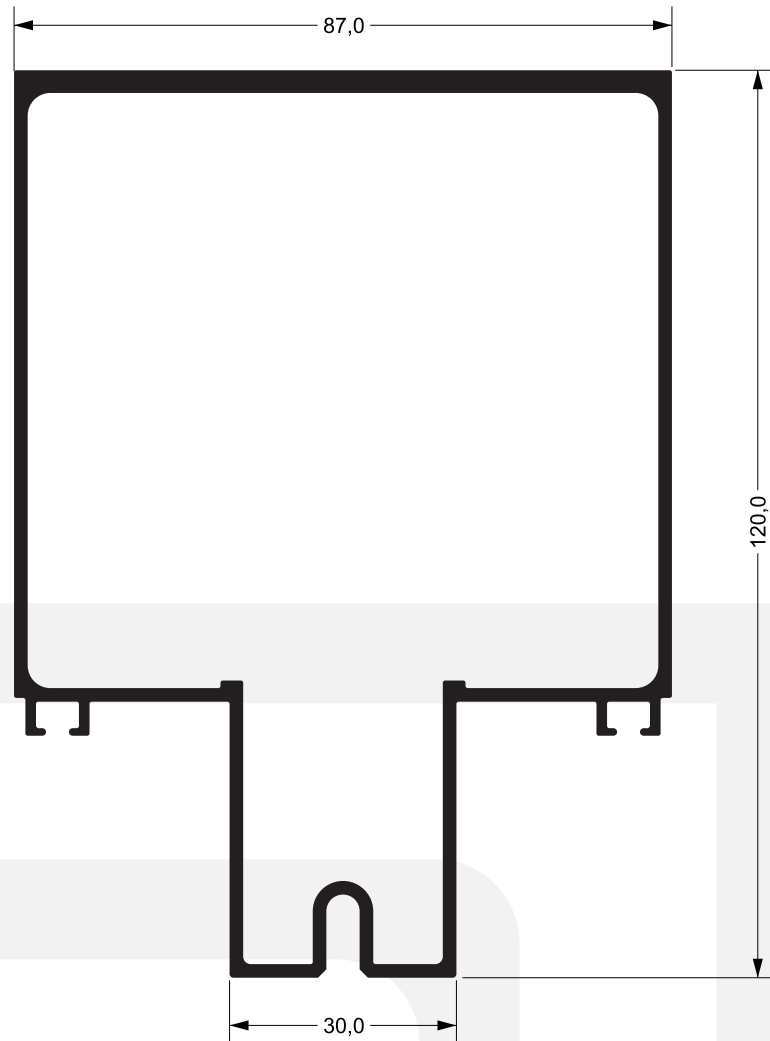

RA-375  
2,454 kg/m

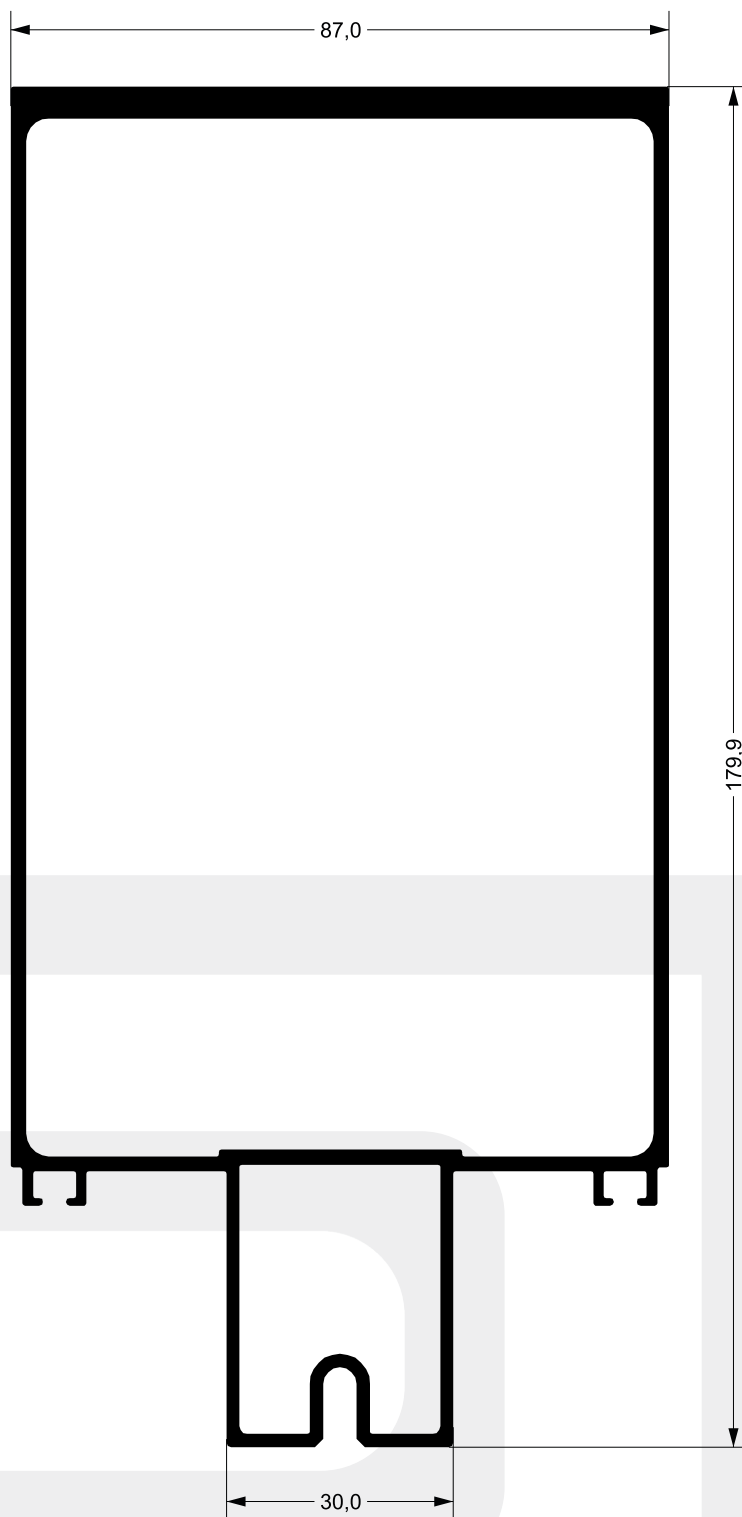

**RA-390**  
3,630 kg/m



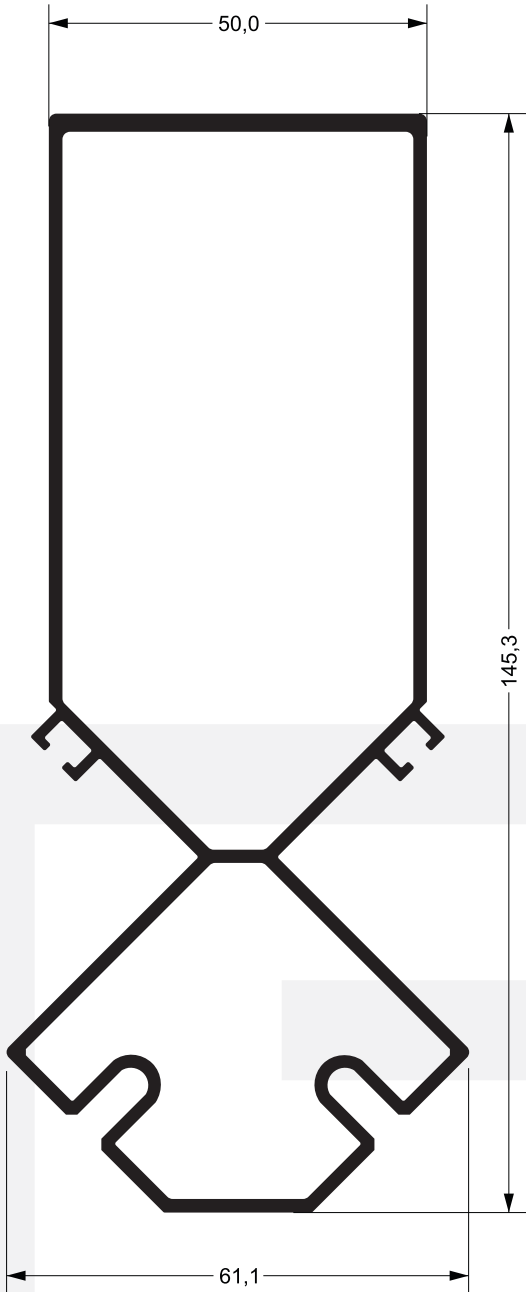

**RA-236**  
2,364 kg/m

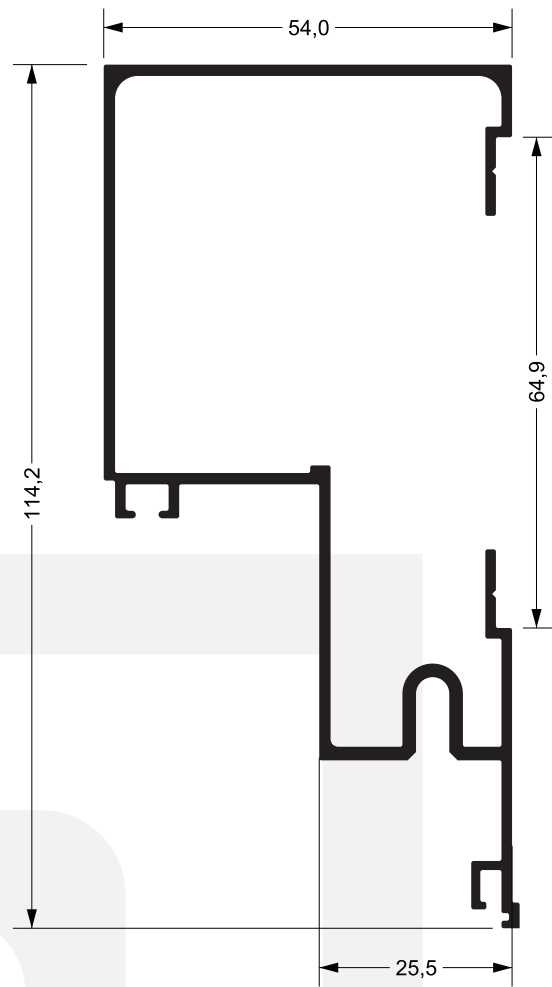

**RA-235**  
1,544 kg/m

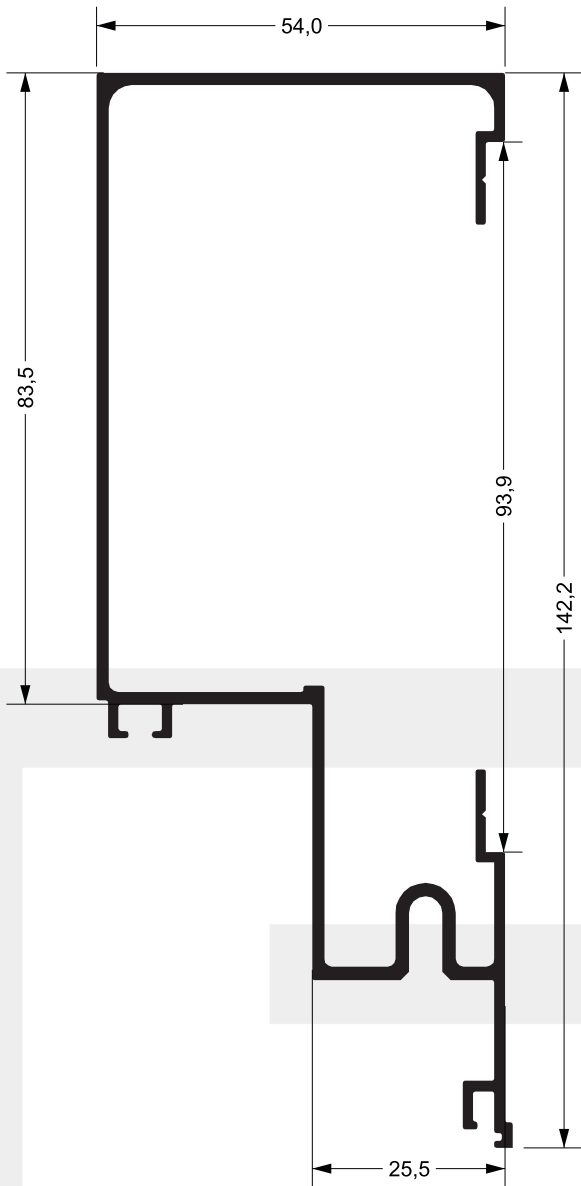

**RA-278**  
1,451 kg/m

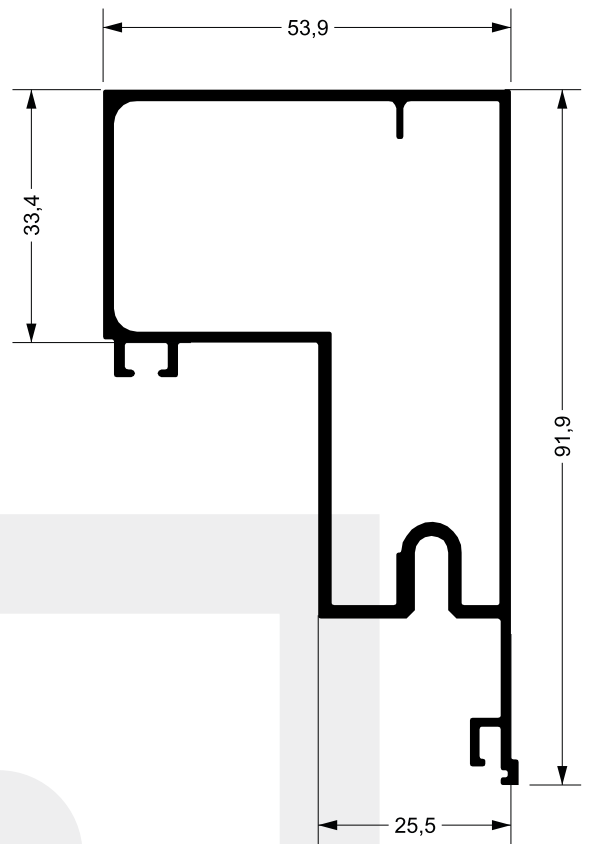

**RA-347**  
1,330 kg/m

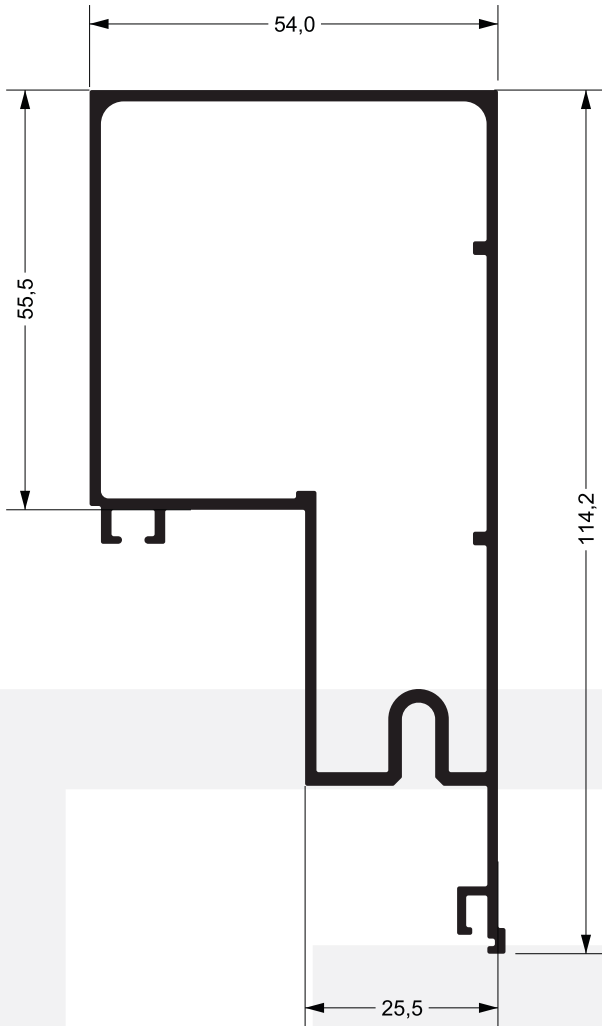

**RA-515**  
1,470 kg/m

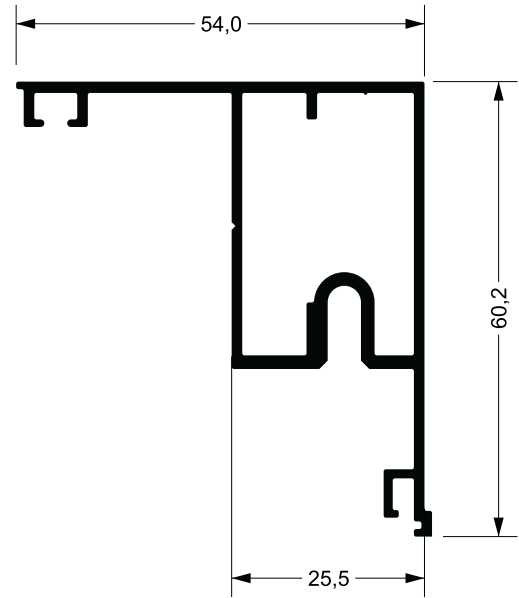

**RA-516**  
0,894 kg/m

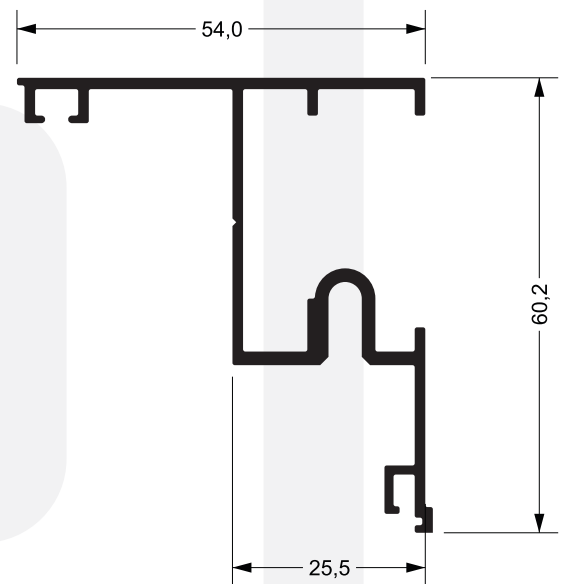

**RA-294**  
0,785 kg/m

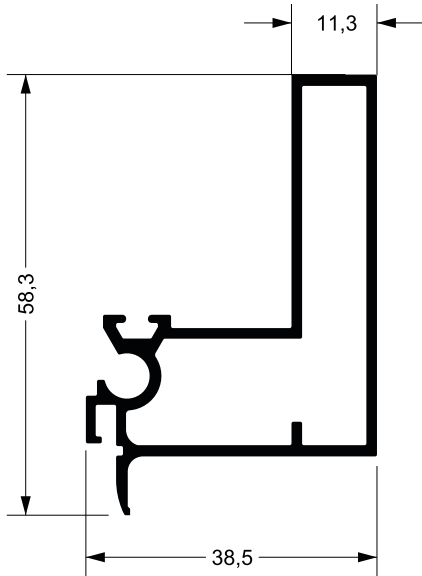

**RA-255**  
0,765 kg/m

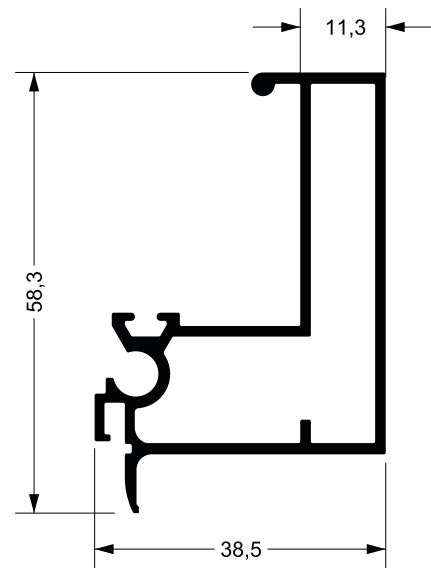

**RA-256**  
0,800 kg/m

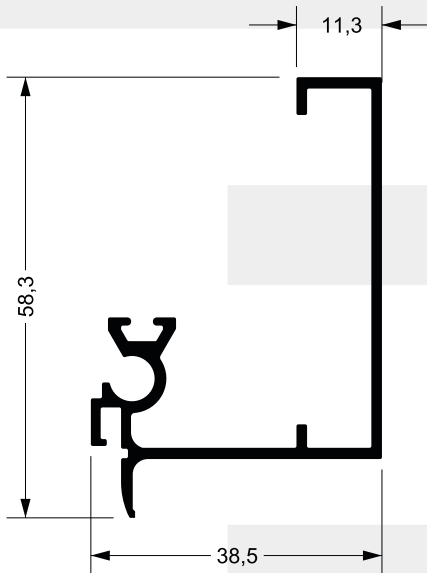

**RA-258**  
0,590kg/m

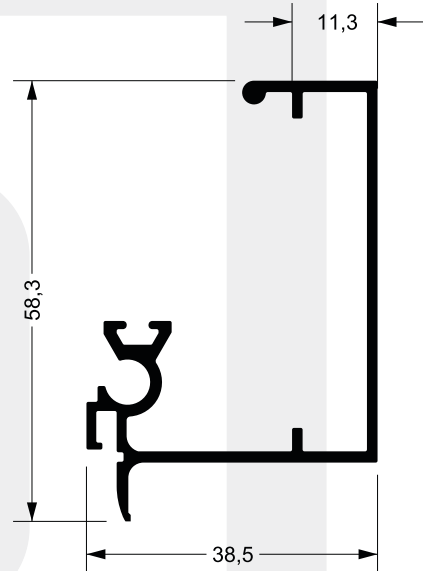

**RA-259**  
0,594kg/m



**raltex**  
PERFIS DE ALUMÍNIO

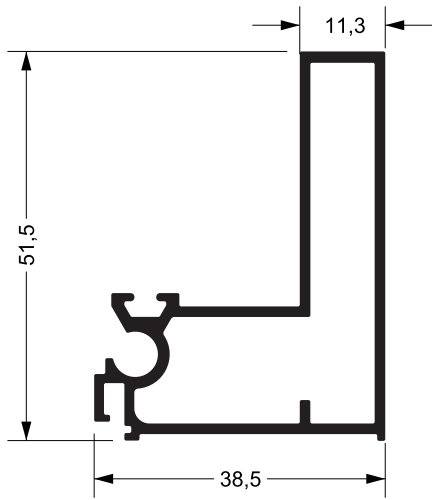

**RA-245**  
0,742 kg/m

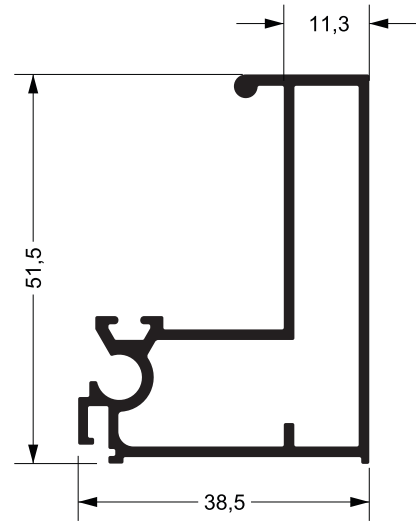

**RA-230**  
0,770 kg/m

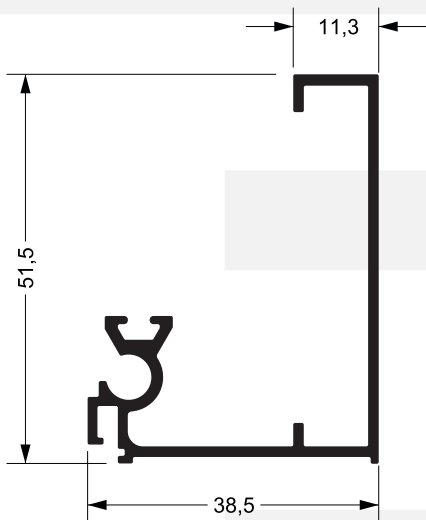

**RA-228**  
0,588kg/m

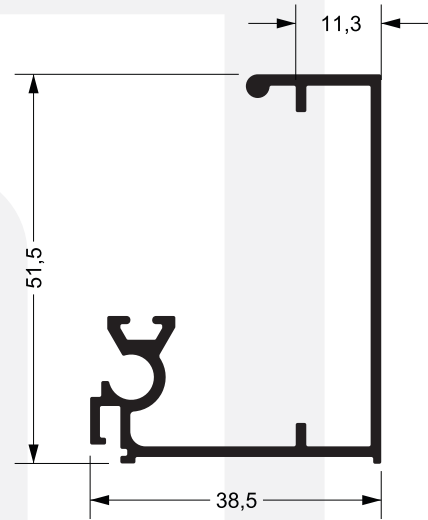

**RA-232**  
0,603kg/m

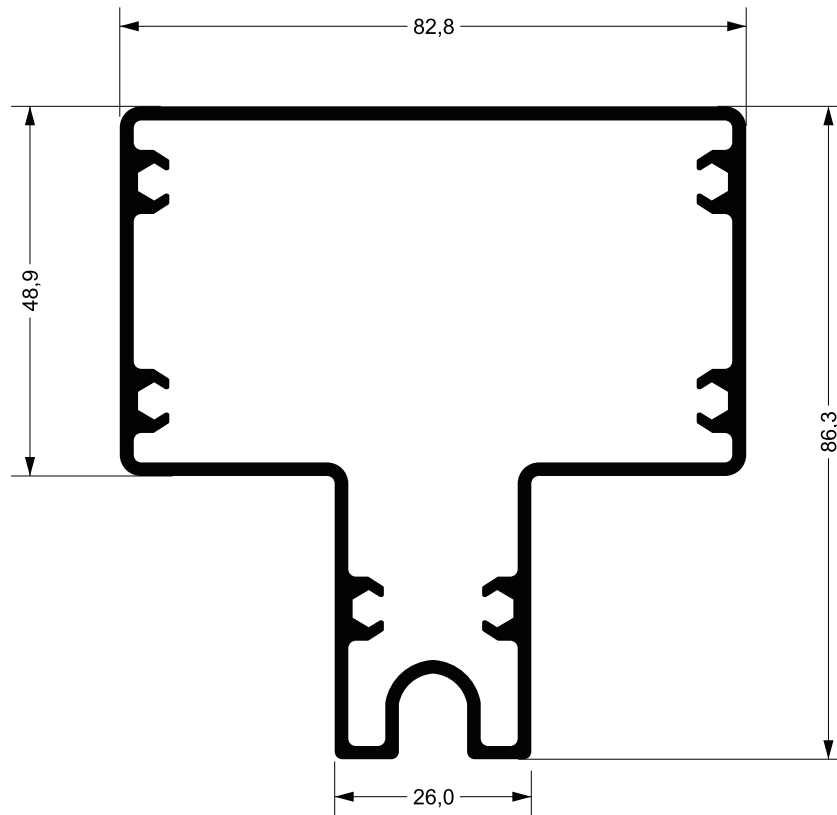

**RA-223**  
1,978 kg/m

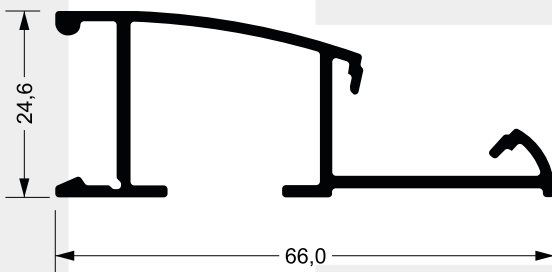

**RA-238A**  
0,572 kg/m

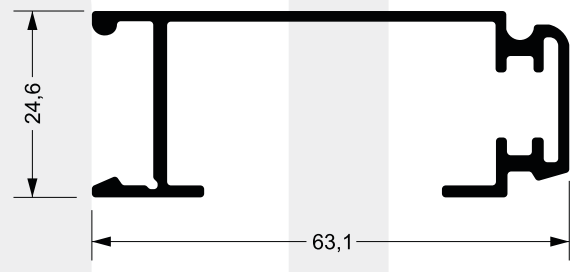

**RA-239A**  
0,582 kg/m

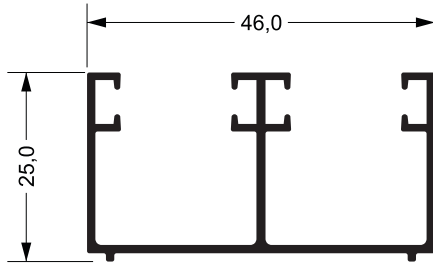

**U-1108D**  
0,500 kg/m

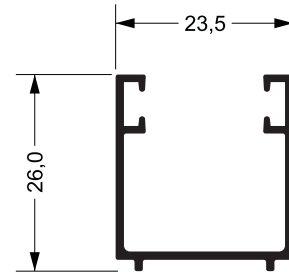

**U-1108**  
0,360 kg/m

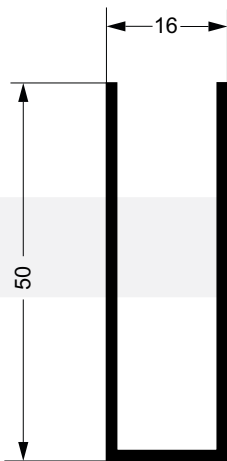

**U-555G**  
0,333 kg/m

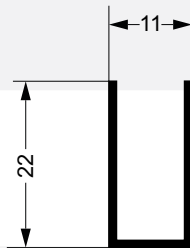

**PU-041**  
0,144 kg/m

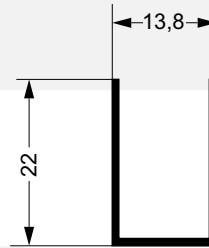

**PU-042**  
0,157 kg/m

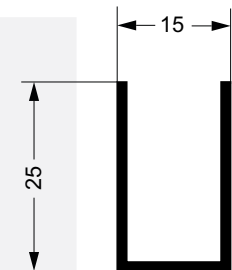

**U-555**  
0,200 kg/m

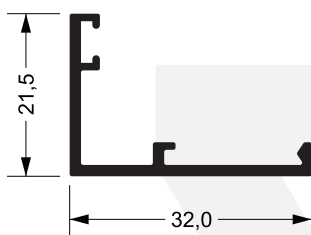

**29022**  
0,264 kg/m

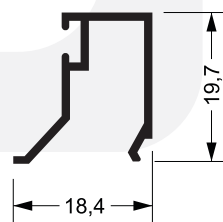

**39077**  
0,177 kg/m

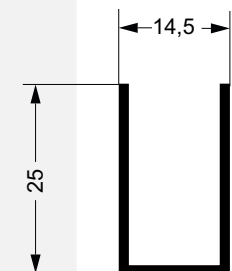

**U-555L**  
0,158 kg/m

# Vidro Temperado 8mm



**raltext**  
PERFIS DE ALUMÍNIO

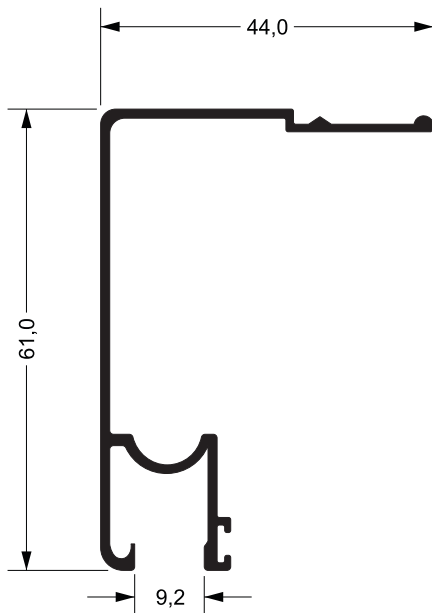

**RAL-713L**  
0,600 kg/m

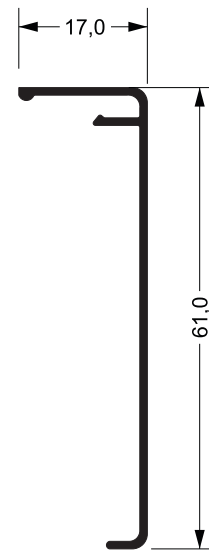

**RAL-714L**  
0,260 kg/m

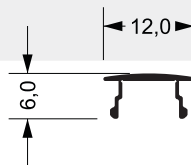

**RAL-491L**  
0,090 kg/m

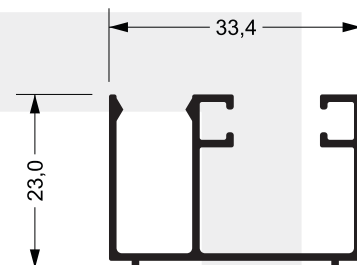

**RAL-306L**  
0,320 kg/m

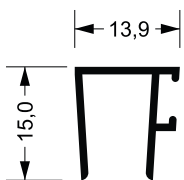

**39137**  
0,138 kg/m

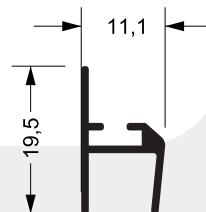

**BX-104**  
0,100 kg/m

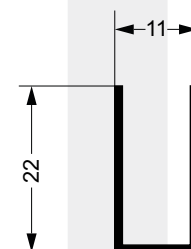

**PU-041**  
0,144 kg/m





# Vidro Temperado 10mm

**raltext**  
PERFIS DE ALUMÍNIO

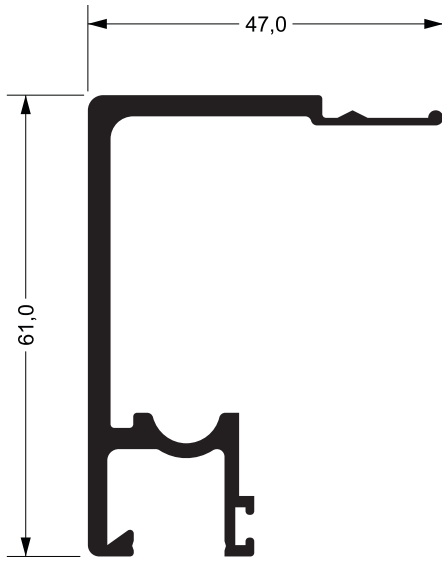

**RAL-713**  
0,910 kg/m

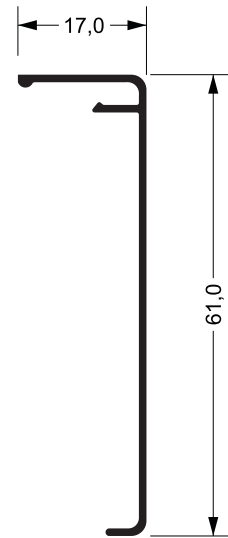

**RAL-714**  
0,390 kg/m

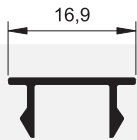

**RAL-491**  
0,105 kg/m

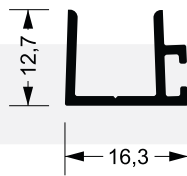

**39143**  
0,143 kg/m

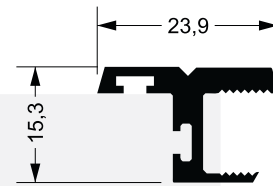

**Y-343**  
0,284 kg/m

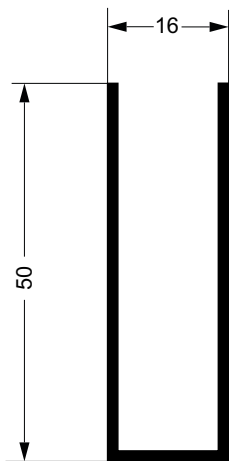

**U-555G**  
0,333 kg/m

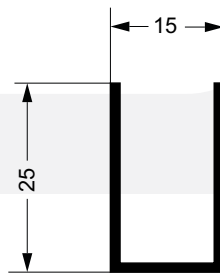

**U-555**  
0,200 kg/m

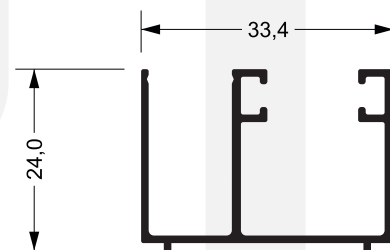

**RAL-306**  
0,404 kg/m



**raltex**  
PERFIS DE ALUMÍNIO



Endereço  
R. Cambaí, 144 Lot. Industrial Veccon Zeta  
Sumaré/SP - CEP: 13178-546



Telefone/WhatsApp  
(19) 3884-2939  
(19) 99890-1555



Via E-mail  
[contato@raltex.com.br](mailto:contato@raltex.com.br)