



raltex

PERFIS DE ALUMÍNIO

CATÁLOGO DE PRODUTOS



CATEGORIA	PÁGINA
Barra Chata	04
Cantoneira Abas Iguais	05
Tubo Quadrado e Retangular	06
Tubo Redondo	07
Perfil "U"	08
Box Frizado	09
Box Frizado FX	10
Box Liso	11
Temperado 8 mm	12
Kit Box Temperado 8 mm	14
Temperado 10 mm	15
Trilho Stanley	17
Contra Marco	18
Arremates	19
Linha 25	20
Linha 30	25
Linha Suprema	28
Linha Gold	42
Linha Integrada	53
Veneziana	58
Gradil	59
Corrimão / Guarda Copo	60
Portões	62
Lambril	63
Linha 42	65
Perfis Diversos	66

ÍNDICE POR CÓDIGO

CÓDIGO	PÁGINA	CÓDIGO	PÁGINA	CÓDIGO	PÁGINA	CÓDIGO	PÁGINA
30-001	27	CG-074	59	I-090	23	LG-072	50
80-034	52	CG-075	59	I-105	24	LG-124	50
80-035	52	CG-077	59	I-154	9	LG-158	51
80-041	51	CG-078	60	I-154L	9	LG-162	51
80-058	52	CG-079	60	L-009	5	MD-238	55
A-022	11	CG-083	59	L-012	5	ME-013	41
A-034	20	CL-006	18	L-013	5	MN-001	53
A-041	25	CL-011	18	L-014	5	MN-002	53
A-055	20	CM-060	18	L-019	5	MN-003	53
A-056	20	CM-063	18	L-022	5	MN-005	54
A-058	20	CM-098	18	L-025	5	MN-006	54
A-087	9	CM-151	18	L-1002	5	MN-007	55
A-144	25	CX-001	66	L-1009	5	MN-010	55
BAR-016	4	CX-002	66	L-1013	5	MN-014	19 54
BAR-022	4	CX-600	62	L-1405	5	MN-014	19 54
BAR-050	4	D-055	60	L-387	23	MN-015	55
BAR-052	4	D-069	61	L-405	5	MN-031	56
BAR-053	4	D-078	61	L-519	27	MN-032	56
BAR-061	4	D-079	61	L-713	15	MN-050	57
BAR-091	4	D-082	60	LG-002	42	MN-055	57
BAR-096	4	D-095	60	LG-003	42	MP-347	19
BAR-145	4	D-102	61	LG-006	42	P-064	26
BAR-193	4	D-103	60	LG-007	42	P-068	27
BX-001	10	E-117	11	LG-016	42	P-078	25
BX-002	10	E-150	25	LG-017	43	P-084	26
BX-003	10	E-256	9	LG-020	43	P-120	26
BX-004	10	E-277	22	LG-021	43	P-127	20
BX-005	10	E-305	15	LG-024	44	P-140	20
BX-006	10	E-362	62	LG-026	44	P-145	20
BX-026	16	E-364	62	LG-027	44	P-146	21
BX-027	16	EX-015	66	LG-028	44	P-147	20
BX-101	8 13 14	EX-068	17	LG-042	44	P-151	21
BX-102	8 13 14	EX-071	60	LG-043	45	P-152	20
BX-103	13	EX-087	60	LG-044	45	P-153	21
BX-104	13 14	EX-1090	13	LG-045	45	P-167	21
BX-105	13	EX-1091	16	LG-046	45	P-227	21
BX-108	14	EX-306	16	LG-047	45	P-255	21
BX-109	13 14	EX-306L	13	LG-048	46	P-264	27
BX-110	13 14	EX-398	11 16	LG-049	46	P-268	65
BX-113	15	EX-491	16	LG-050	46	P-270	26
BX-114	8 13	EX-713	15	LG-051	46	P-273	26
BX-115	13	EX-713L	12	LG-055	47	P-280	65
BX-117	14	EX-714	12 15	LG-056	47	P-318	21
BX-118	8 13	FAL-1176	65	LG-057	47	P-319	21
BX-119	16 17	FAL-1177	64	LG-059	47	P-358	22
BX-120	16 17	FAL-1328	64	LG-062	47	P-412	22
BX-122	12	FAL-157	66	LG-064	48	P-414	22
BX-123	8 16	FAL-173	19	LG-066	48	P-419	26
BX-864	12	FAL-220	64	LG-070	49	P-574	22
BX-865	12	I-083	11	LG-071	49	PU-104	8 16

CÓDIGO	PÁGINA	CÓDIGO	PÁGINA	CÓDIGO	PÁGINA	CÓDIGO	PÁGINA
RM-014	19	SU-068	35	SU-276	41	U-1076	65
RM-016	19	SU-069	35	SU-279	41	U-1098	17
RM-110	19	SU-070	35	SU-302	41	U-396	11
SU-001	28	SU-079	36	T-123	66	U-397	11
SU-002	28	SU-080	36	TP-600	62	U-399	11
SU-003	28	SU-081	36	TUB-009	7	U-482	25
SU-004	28	SU-082	36	TUB-018	7	U-491	16
SU-005	28	SU-083	36	TUB-027	7	U-509	8
SU-006	28	SU-084	36	TUB-028	7	U-522	24
SU-007	29	SU-086	36	TUB-038	7	U-555	8
SU-008	29	SU-090	36	TUB-046	7	U-555	16
SU-009	29	SU-102	36	TUB-058	7	U-652	9
SU-010	29	SU-103	36	TUB-061	7	U-653	9
SU-011	29	SU-108	36	TUB-074	6	U-654	9
SU-012	30	SU-110	37	TUB-081	7	U-655	9
SU-013	30	SU-111	37	TUB-309	7	U-681	24
SU-014	30	SU-120	37	TUB-311	7	U-990	17
SU-015	30	SU-121	37	TUB-4003	6	VZ-006	58
SU-021	31	SU-122	37	TUB-4008	6	VZ-024	58
SU-023	31	SU-123	38	TUB-4011	6	VZ-051	59
SU-026	31	SU-186	38	TUB-4020	6	Y-106	11
SU-027	32	SU-187	38	TUB-4021	6	Y-107	11
SU-028	32	SU-188	38	TUB-4051	6	Y-126	23
SU-029	32	SU-190	38	TUB-4053	6	Y-140	27
SU-030	33	SU-191	38	TUB-4054	6	Y-181	23
SU-031	33	SU-192	38	TUB-4061	6	Y-195	23
SU-032	33	SU-200	39	TUB-4513	6	Y-215	23
SU-033	34	SU-203	39	TUB-4517	6	Y-310	9
SU-040	34	SU-225	39	TUB-4536	6	Y-311	9
SU-041	34	SU-226	39	TUB-4545	6	Y-335	63
SU-042	34	SU-227	39	TUB-4569	6	Y-343	16
SU-043	34	SU-228	39	TUB-4576	6	Y-355	63
SU-047	34	SU-230	39	TUB-4591	6	Y-429	63
SU-049	35	SU-238	40	TUB-4599	6	Z-175	24
SU-053	35	SU-241	40	TUB-4599R	6	Z-176	24
SU-055	35	SU-242	40	TUB-508	7	Z-203	58
SU-056	35	SU-243	40	TUB-610	7		
SU-057	35	SU-245	40	TUB-675	7		
SU-061	35	SU-250	41	U-036	8		

BARRA CHATA

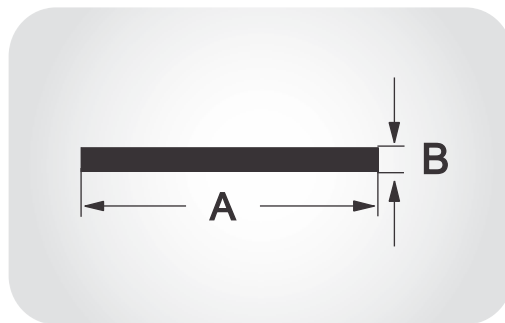

PERFIL	PESO KG/M	MILÍMETROS		POLEGADAS	
		A	B	A	B
BAR-145	0,066	15,88	1,58	5/8	1/16
BAR-193	0,156	19,00	3,00	3/4	1/8
BAR-050	0,246	19,00	4,76	3/4	3/16
BAR-052	0,288	22,22	4,76	7/8	3/16
BAR-016	0,224	25,40	3,18	1	1/8
BAR-053	0,332	25,40	4,76	1	3/16
BAR-091	0,451	25,40	6,35	1	1/4
BAR-022	0,324	38,10	3,18	1.1/2	1/8
BAR-096	0,673	38,10	6,35	1.1/2	1/4
BAR-061	0,651	50,80	4,76	2	3/16

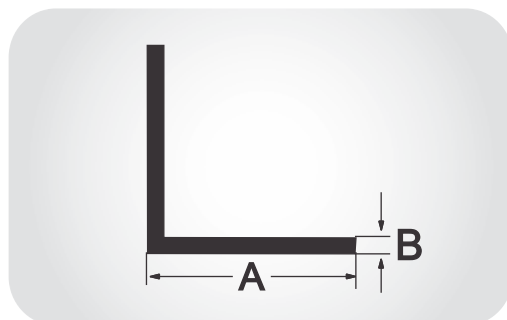

PERFIL	PESO KG/M	MILÍMETROS		POLEGADAS	
		A	B	A	B
L-1002	0,074	12,70	1,00	1/2	
L-1405	0,078	15,87	1,00	5/8	
L-405	0,132	15,87	1,50	5/8	1/16
L-1009	0,106	19,05	1,00	3/4	
L-009	0,152	19,05	1,50	3/4	1/16
L-012	0,328	22,20	3,00	7/8	1/8
L-1013	0,192	25,40	1,00	1	
L-013	0,211	25,40	1,50	1	1/16
L-014	0,398	25,40	3,00	1	1/8
L-019	0,750	31,75	4,76	1.1/4	3/16
L-022	0,631	38,10	3,18	1.1/2	1/8
L-025	0,871	50,80	3,18	2	1/8

TUBO QUADRADO E RETANGULAR

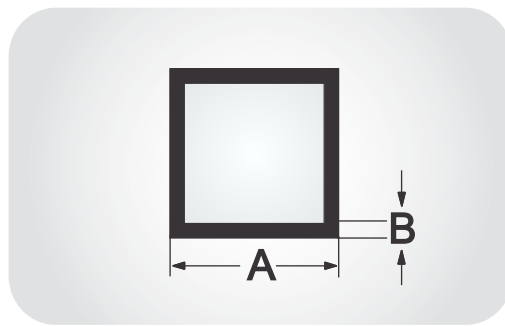

PERFIL	PESO KG/M	MILÍMETROS		POLEGADAS	
		A	B	A	B
TUB-4051	0,200	19,05	1,00	3/4	
TUB-4003	0,297	19,05	1,58	3/4	1/16
TUB-4061	0,307	25,40	1,00	1	
TUB-4008	0,425	25,40	1,58	1	1/16
TUB-4053	0,640	38,10	1,58	1.1/2	1/16
TUB-4021	0,660	50,80	1,40	2	
TUB-4020	1,215	50,80	2,00	2	
TUB-4011	0,526	31,75	1,58	1.1/4	1/16
TUB-4054	2,850	100	100	4	4

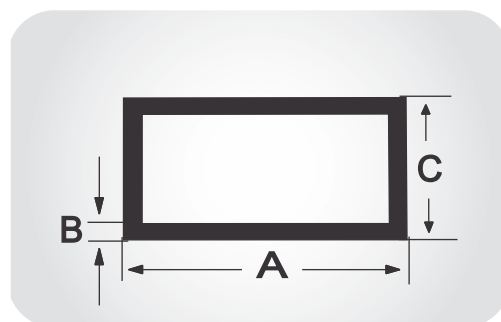

PERFIL	PESO KG/M	MILÍMETROS			POLEGADAS		
		A	B	C	A	B	C
TUB-074	0,261	25,40	1,20	12,70	1		1/2
TUB-4545	0,465	38,10	1,20	25,40	1.1/2		1
TUB-4576	0,365	50,80	0,90	25,40	2		1
TUB-4536	0,567	50,80	1,58	12,70	2	1/16	1/2
TUB-4569	0,723	50,80	1,58	25,40	2	1/16	1
TUB-4513	0,995	50,80	2,00	38,10	2		1.1/2
TUB-4591	0,755	76,20	1,30	25,40	3		1
TUB-4517	1,298	76,20	2,00	38,10	3		1.1/2
TUB-4599R	1,733	101,60	1,58	50,80	4	1/16	2
TUB-4599	1,500	101,60	1,80	50,80	4		2

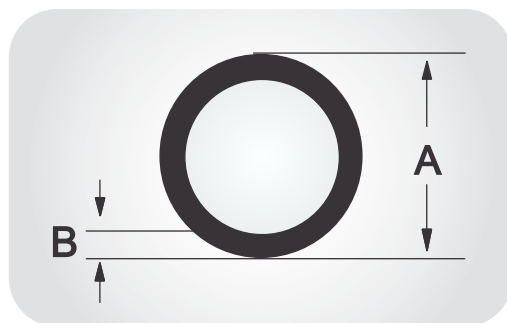

PERFIL	PESO KG/M	MILÍMETROS		POLEGADAS	
		A	B	A	B
TUB-009	0,132	12,70	1,20	1/2	
TUB-018	0,170	15,87	1,20	5/8	
TUB-027	0,182	19,05	1,00	3/4	
TUB-028	0,254	19,05	1,58	3/4	1/16
TUB-038	0,260	22,22	1,58	7/8	1/16
TUB-046	0,340	25,40	1,50	1	1/16
TUB-058	0,393	31,75	1,58	1.1/4	1/16
TUB-061	0,800	31,75	3,18	1.1/4	1/8
TUB-675	0,556	38,10	1,58	1.1/2	1/16
TUB-081	0,612	44,45	1,58	1.3/4	1/16
TUB-508	0,468	50,80	1,00	2	
TUB-610	0,684	50,80	1,00	2	
TUB-309	0,800	63,50	1,45	2.1/2	
TUB-311	1010,0	76,20	1,58	3	1/16

PERFIL "U"

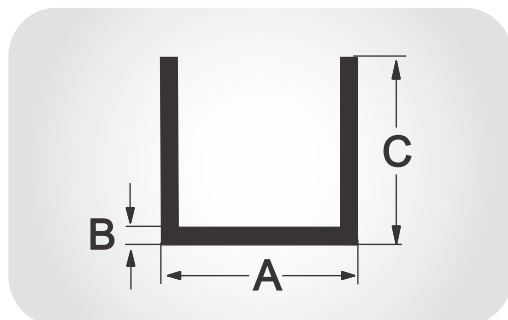

PERFIL	PESO KG/M	MILÍMETROS			POLEGADAS		
		A	B	C	A	B	C
U-036	0,100	9,53	1,40	9,53	3/8		3/8
BX-118	0,097	10,80	0,90	15,00			
BX-114	0,183	11,20	1,00	25,00			1
BX-101	0,114	11,00	1,00	20,00			
BX-102	0,127	13,80	1,00	20,00			
PU-104	0,152	13,80	1,10	24,80			1
U-555	0,251	14,00	1,50	25,00		1/16	1
BX-123	0,436	14,40	1,50	48,00		1/16	
U-509	0,150	15,87	1,20	15,87	5/8		5/8

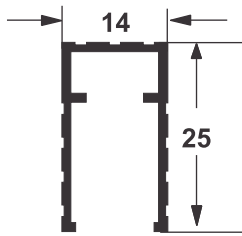

U - 652
0,183 Kg/m



U-653
0,211 Kg/m

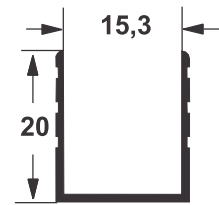

U - 654
0,139 Kg/m

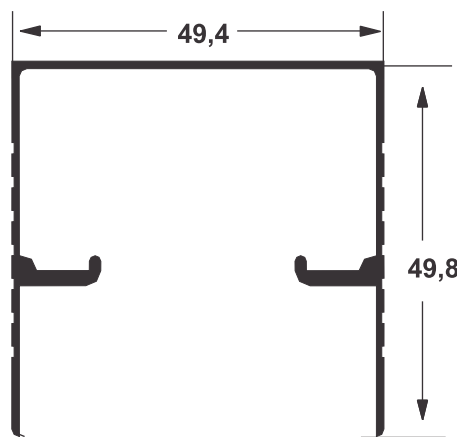

U-655
0,587 Kg/m

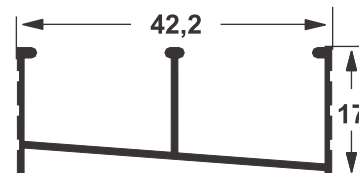

E - 256
0,235 Kg/m

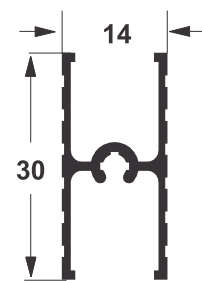

I -154 - 0,232 Kg/m
I -154L - 0,217 Kg/m

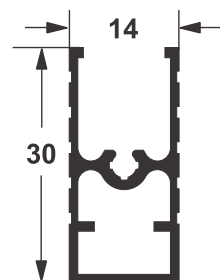

A - 087
0,288 Kg/m

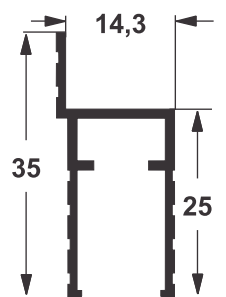

Y - 310
0,217Kg/m

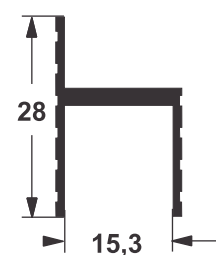

Y - 311
0,216 Kg/m

BOX FRIZADO BX

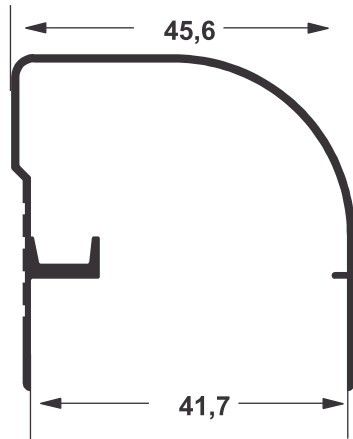

BX - 005
0,455 Kg/m

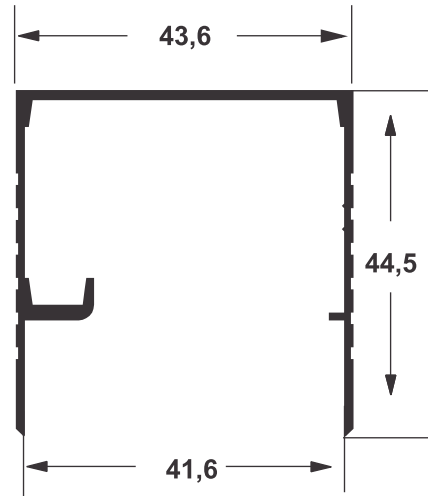

BX - 006
0,409 Kg/m

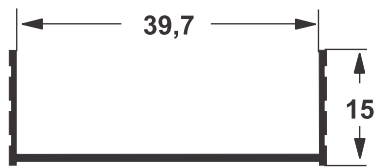

BX - 001
0,167 Kg/m

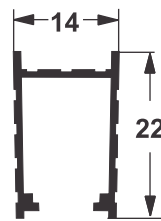

BX - 002
0,151 Kg/m

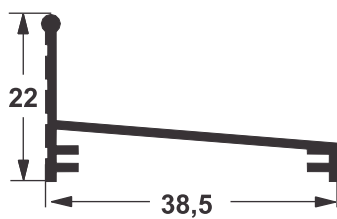

BX - 003
0,209 Kg/m

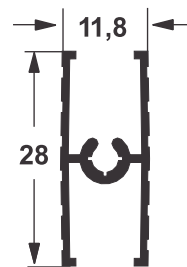

BX - 004
0,195 Kg/m

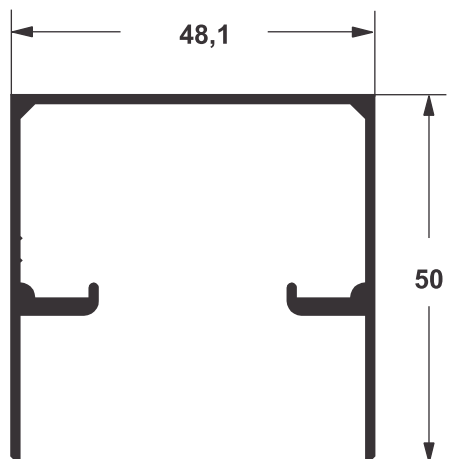

U - 397
0,642 Kg/m



U - 399
0,225 Kg/m

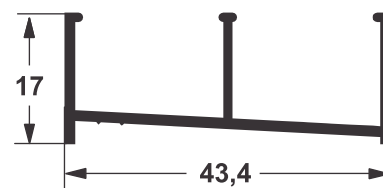

E - 117
0,232 Kg/m

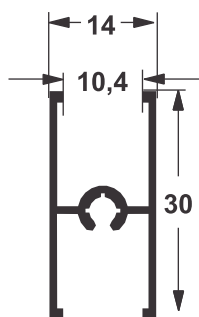

I - 083
0,227 Kg/m

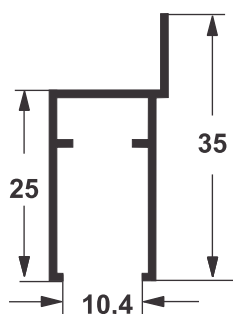

Y - 106
0,260 Kg/m

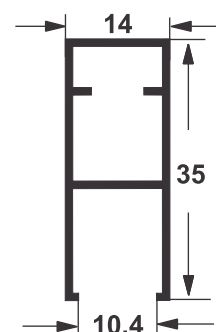

A - 022
0,279 Kg/m

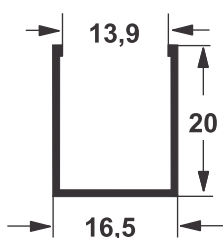

EX - 398
0,139 Kg/m

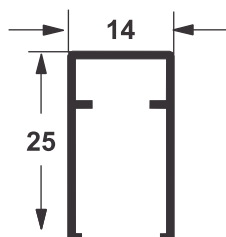

U - 396
0,180 Kg/m

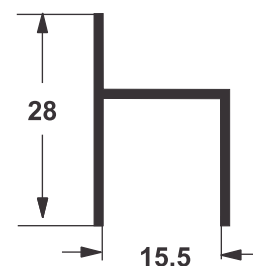

Y - 107
0,188 Kg/m

TEMPERADO 8MM

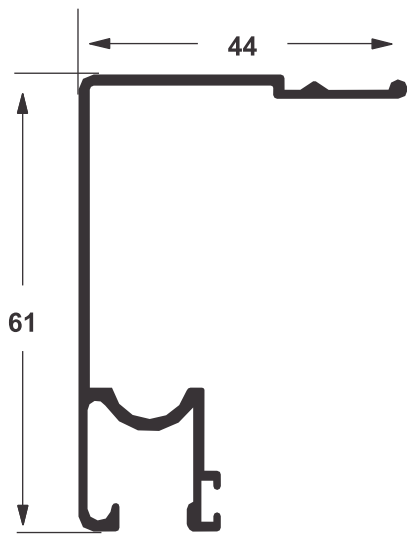

EX - 713 L
0,589 Kg/m



EX - 714
0,242 Kg/m

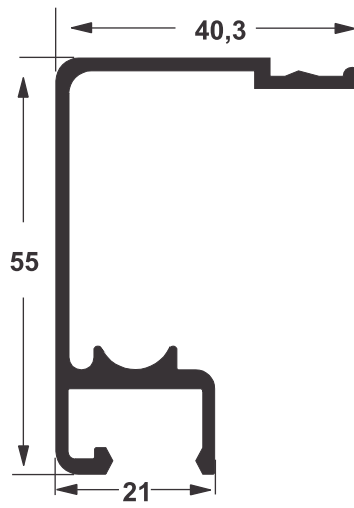

BX - 864
0,777 Kg/m

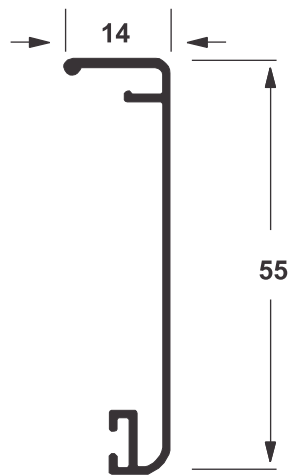

BX - 122
0,245 Kg/m



BX - 865
0,294 Kg/m

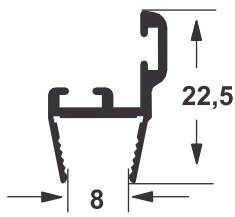

BX - 103
0,201 Kg/m

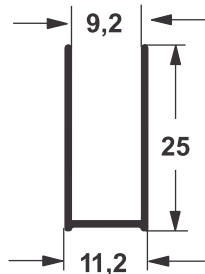

BX - 114
0,183 Kg/m

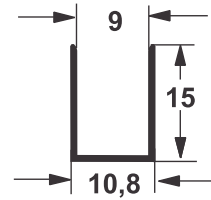

BX - 118
0,097 Kg/m

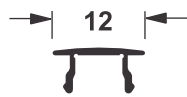

BX - 110
0,063 Kg/m

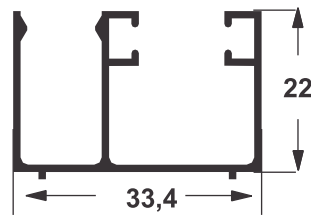

EX - 306 L
0,315 Kg/m

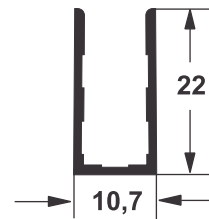

BX - 115
0,158 Kg/m

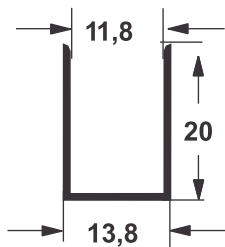

BX - 102
0,127 Kg/m

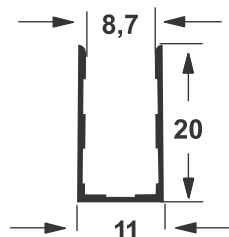

BX - 101
0,114 Kg/m

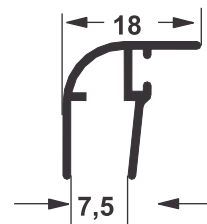

BX - 105
0,142 Kg/m

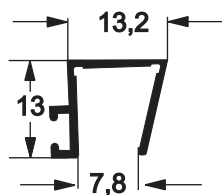

EX-1090
0,120 Kg/m

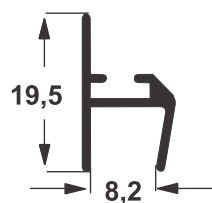

BX - 104
0,127 Kg/m

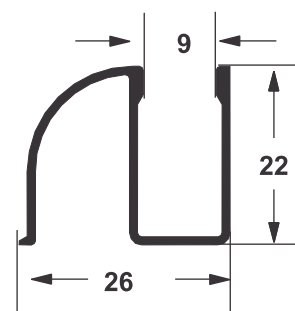

BX - 109
0,263 Kg/m

KIT BOX TEMPERADO 8MM

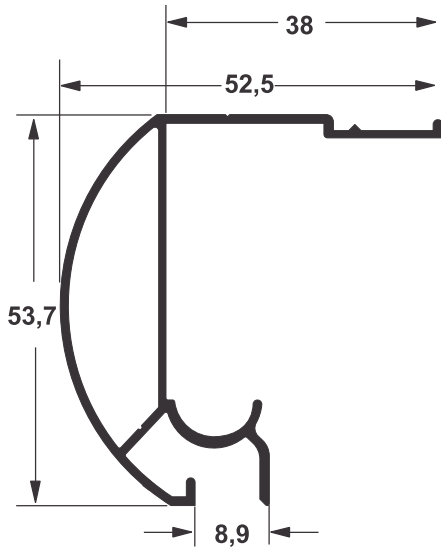

BX - 117
0,624 Kg/m

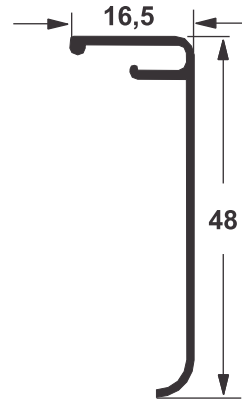

BX - 108
0,190 Kg/m

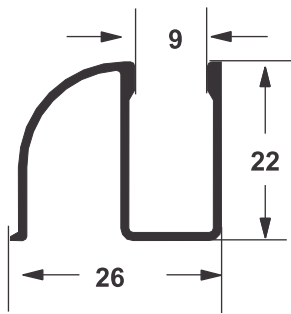

BX - 109
0,263 Kg/m

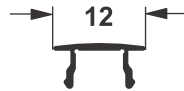

BX - 110
0,063 Kg/m

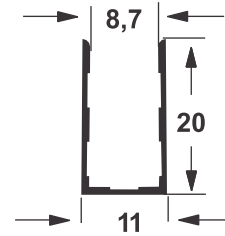

BX - 101
0,114 Kg/m

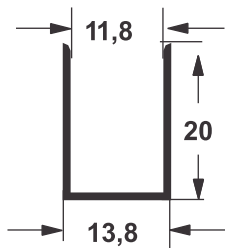

BX - 102
0,127 Kg/m

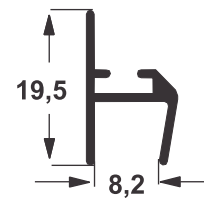

BX - 104
0,127 Kg/m

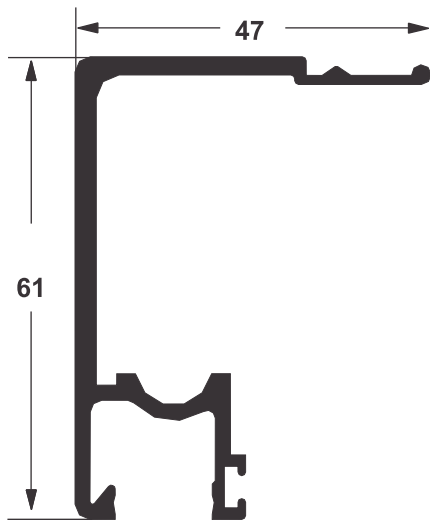

EX - 713
0,968 Kg/m



EX - 714
0,242 Kg/m

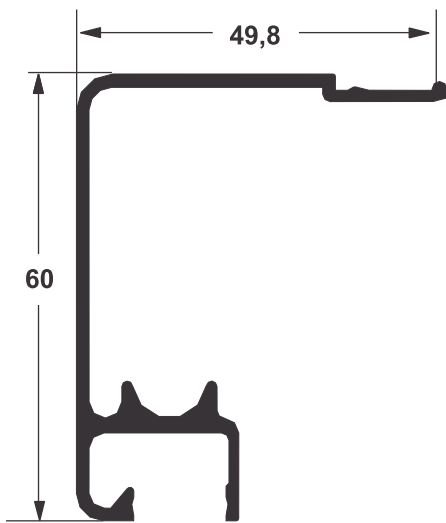

BX - 113
0,794 Kg/m

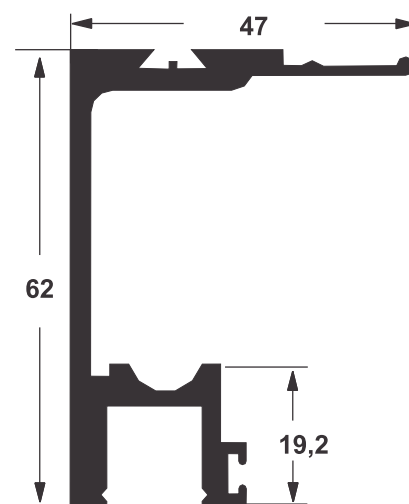

L - 713
1,314 Kg/m

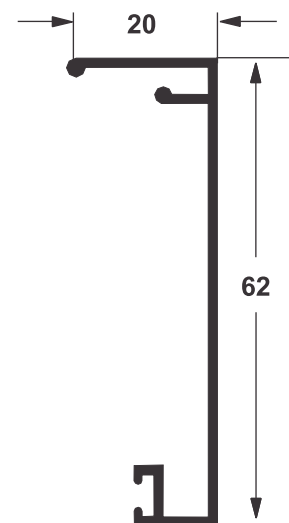

E - 305
0,374 Kg/m

TEMPERADO 10MM

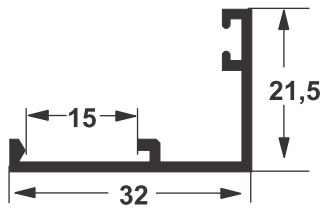

BX - 026
0,214 Kg/m

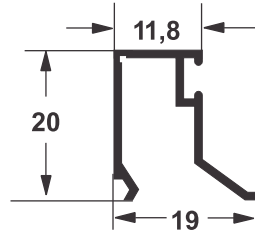

BX - 027
0,166Kg/m

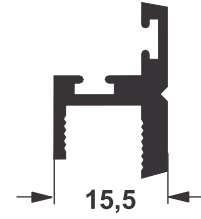

Y - 343
0,317 Kg/m

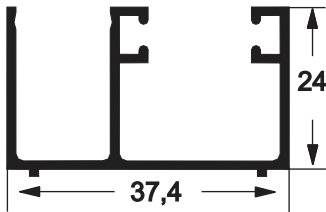

EX-306
0,450 Kg/m

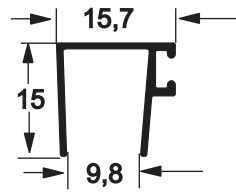

EX-1091
0,140 Kg/m



EX - 491
0,062 Kg/m

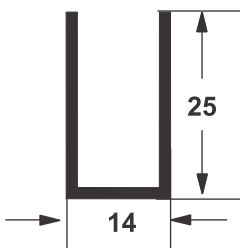

U - 555
0,251 Kg/m

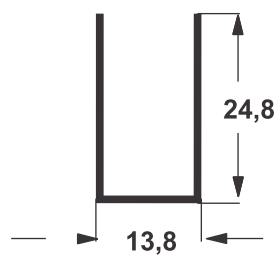

PU - 104
0,152 Kg/m

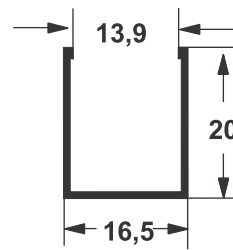

EX - 398
0,141 Kg/m

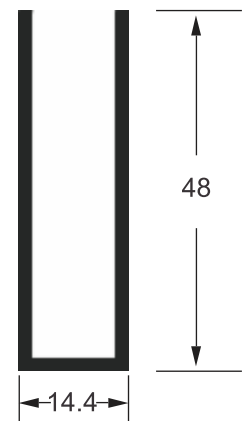

BX-123
0,450 Kg/m

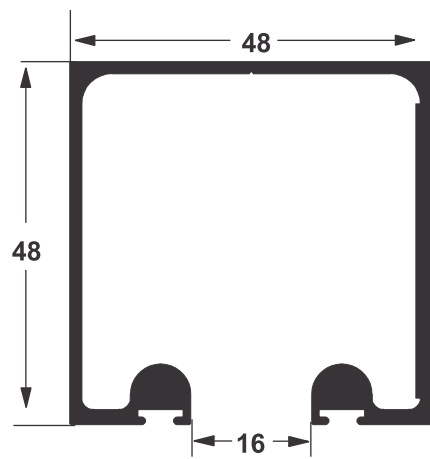

EX - 068
0,982 Kg/m

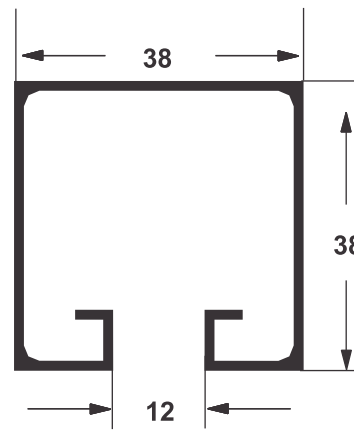

U - 990
0,695 Kg/m

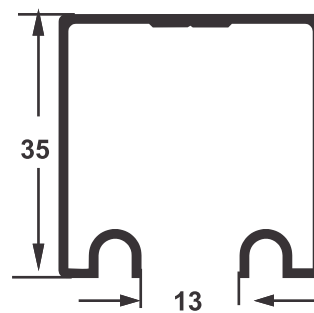

U - 1098
0,492 Kg/m

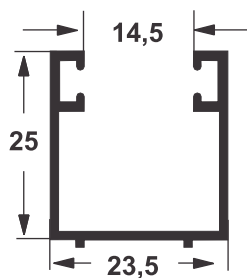

BX - 119
0,249 Kg/m

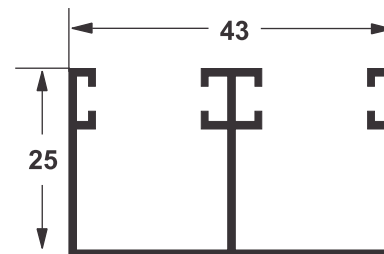

BX - 120
0,387 Kg/m

CONTRA MARCO

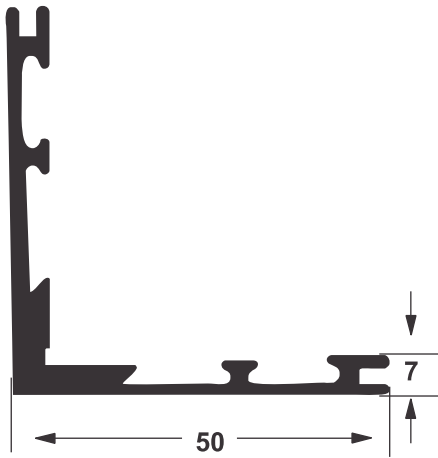

CL - 006
1,057 Kg/m



CL - 011
0,306 Kg/m

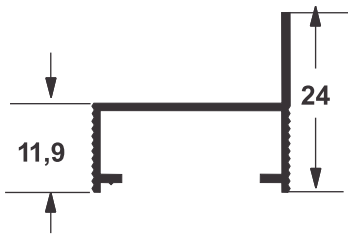

CM - 063
0,195 Kg/m

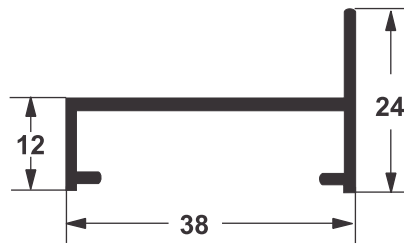

CM - 060
0,239 Kg/m

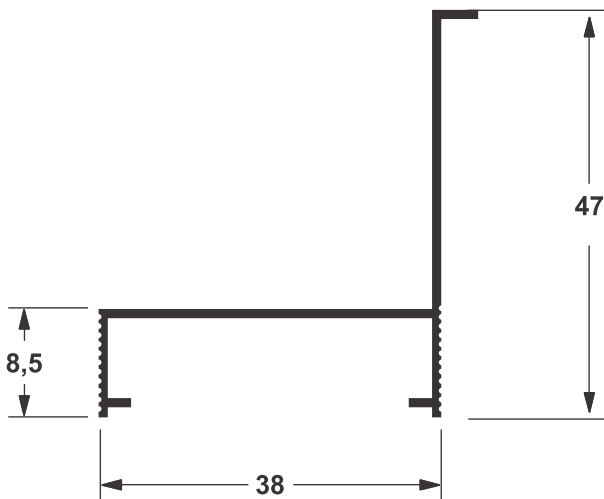

CM - 098
0,390 Kg/m

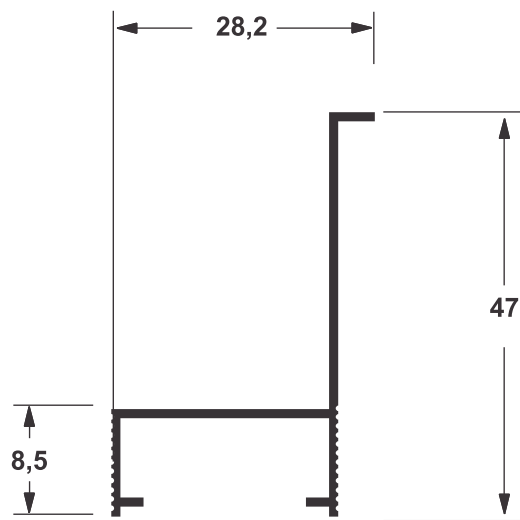

CM - 151
0,309 Kg/m

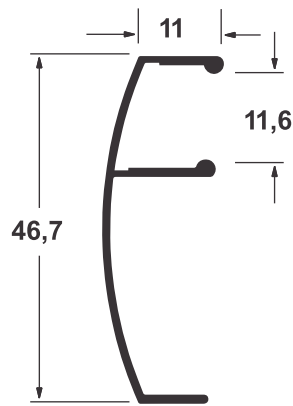

FAL-173
0,235 Kg/m

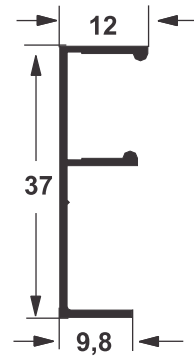

MP-347
0,180 Kg/m

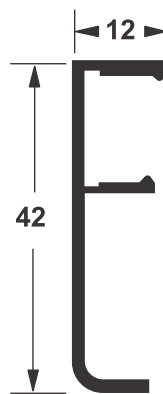

MN - 014
0,214 Kg/m

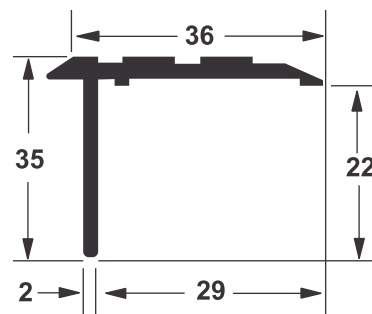

RM - 014
0,364 Kg/m

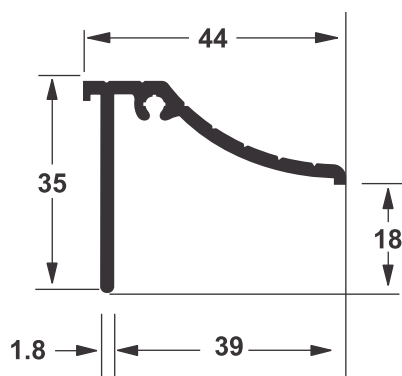

RM - 016
0,431 Kg/m

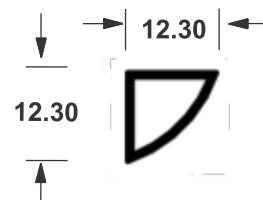

RM - 110
0,115 Kg/m

LINHA 25

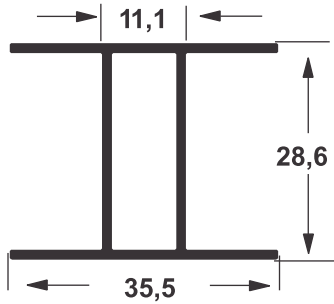

A - 034
0,411 Kg/m

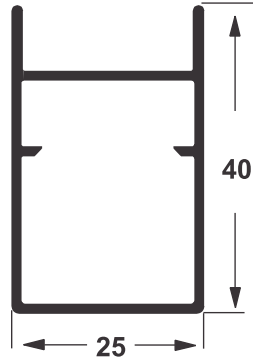

A - 055
0,435 Kg/m

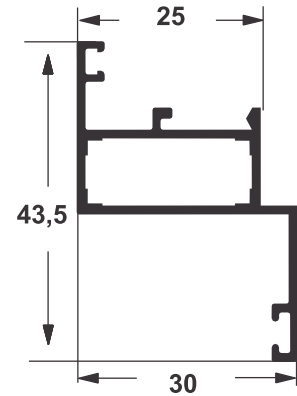

P - 145
0,383 Kg/m

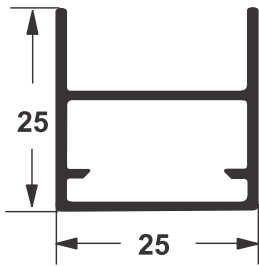

A - 056
0,323 Kg/m

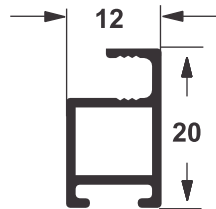

A - 058
0,208 Kg/m

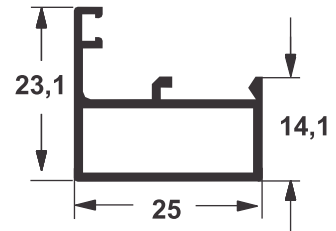

P - 147
0,266 Kg/m

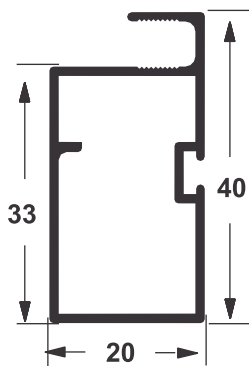

P - 127
0,399 Kg/m

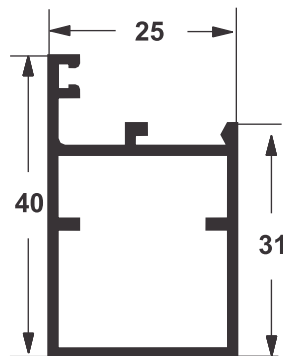

P - 140
0,458 kg/m

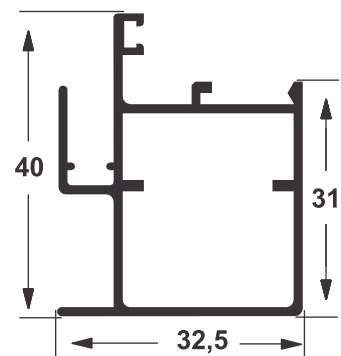

P - 152
0,515 Kg/m

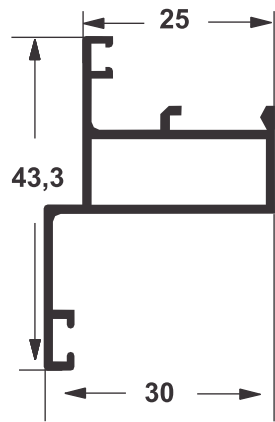

P - 146
0,402 Kg/m

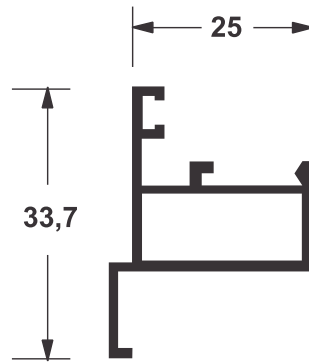

P - 167
0,369 Kg/m

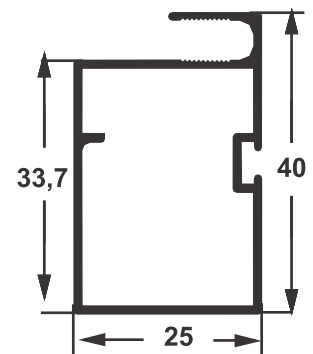

P - 227
0,444 Kg/m

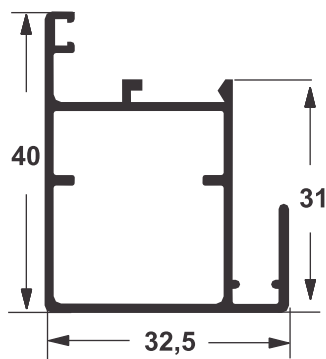

P - 151
0,518 Kg/m

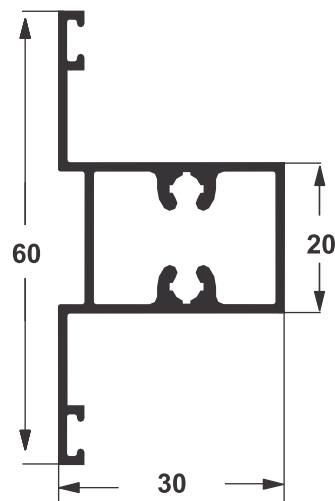

P - 255
0,604 Kg/m

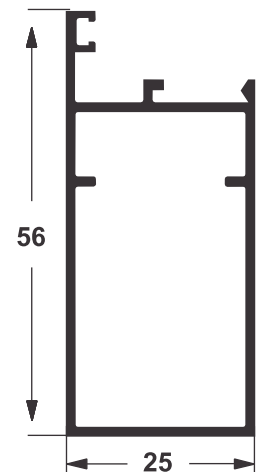

P - 318
0,607 Kg/m

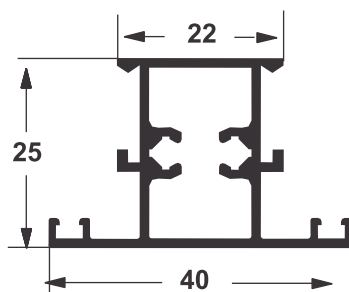

P - 153
0,536 Kg/m

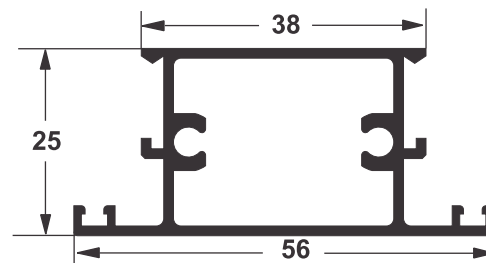

P - 319
0,641 Kg/m

LINHA 25

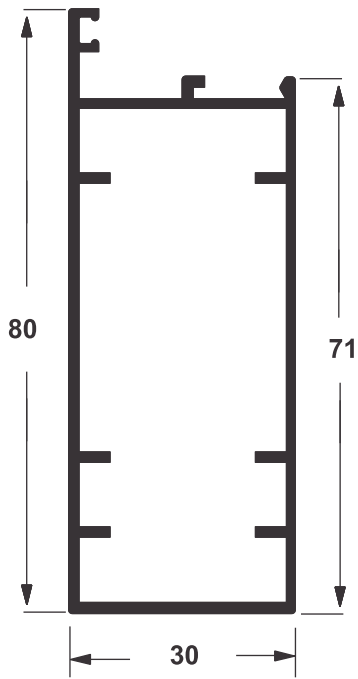

P - 358
0,802 Kg/m

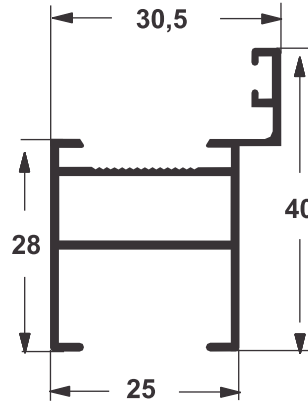

P - 412
0,520 Kg/m

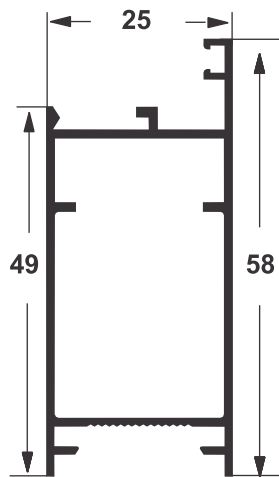

P - 414
0,577 Kg/m

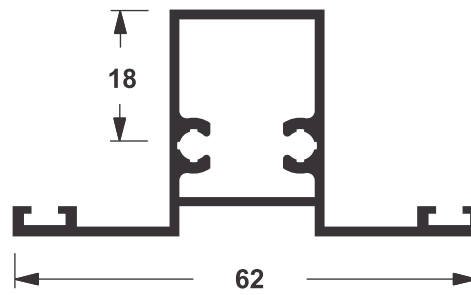

P - 574
0,618 Kg/m

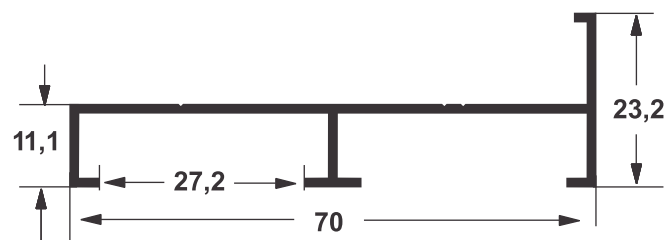

E - 277
0,431 Kg/m

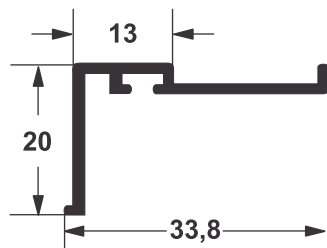

L - 387
0,165 Kg/m

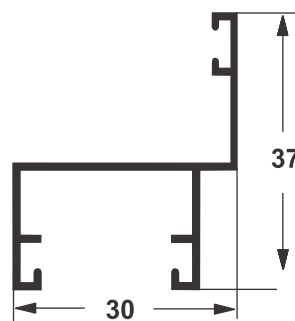

Y - 126
0,298 Kg/m

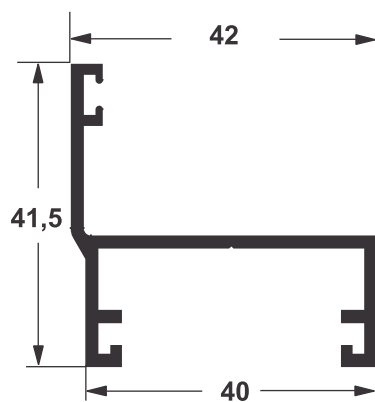

Y - 181
0,553 Kg/m

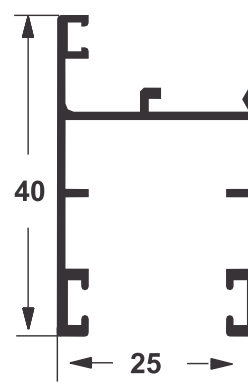

Y - 195
0,409 Kg/m

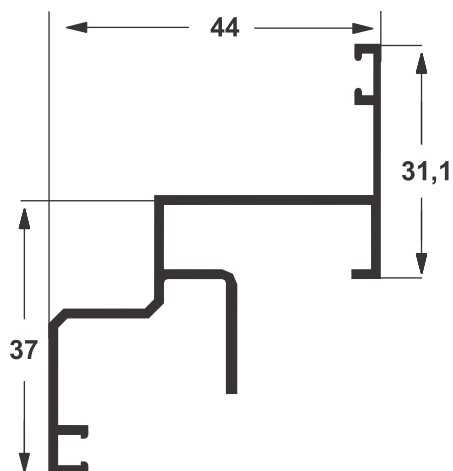

Y - 215
0,494 Kg/m

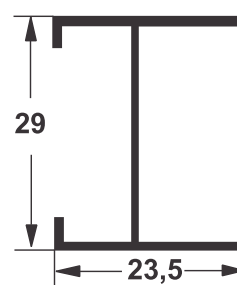

I - 090
0,242 Kg/m

LINHA 25

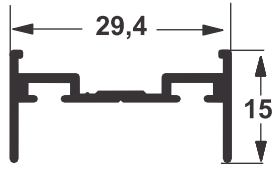

I - 105
0,244 Kg/m

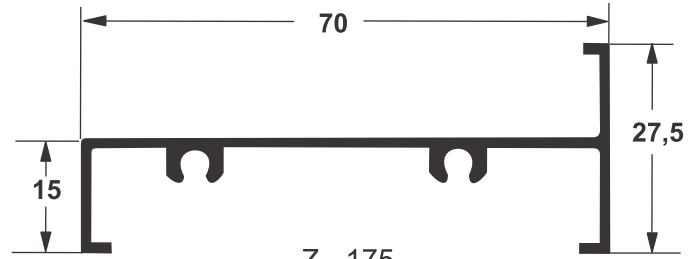

Z - 175
0,510 Kg/m

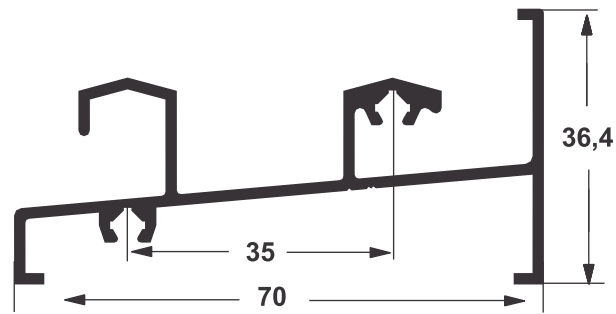

Z - 176
0,773 Kg/m

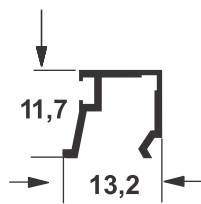

U - 522
0,113 Kg/m

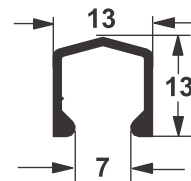

U - 681
0,132 Kg/m

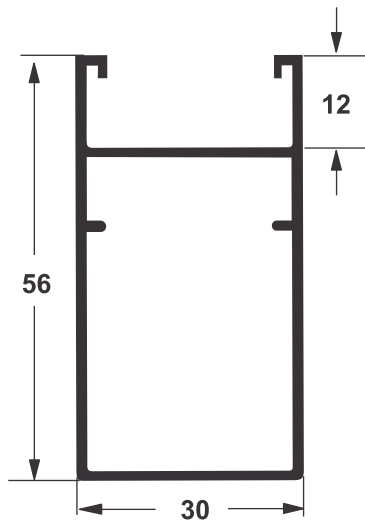

A - 041
0,578 Kg/m

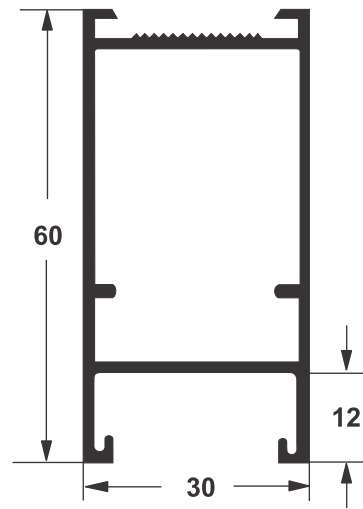

A - 144
0,629 Kg/m

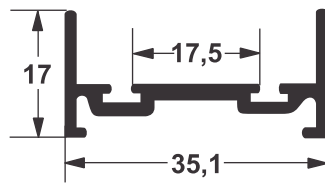

E - 150
0,264 Kg/m

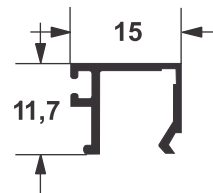

U - 482
0,115 Kg/m

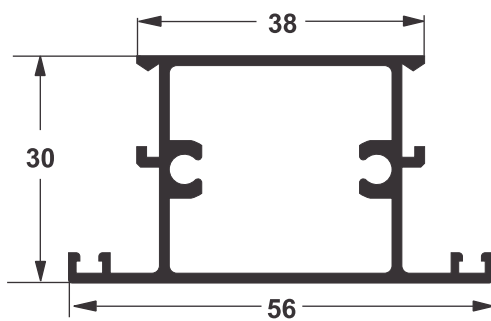

P - 078
0,671 Kg/m

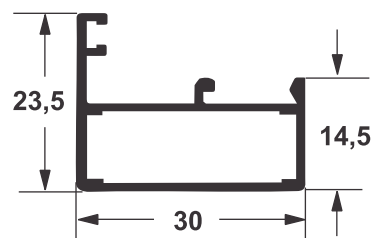

P - 064
0,323 Kg/m

LINHA 30

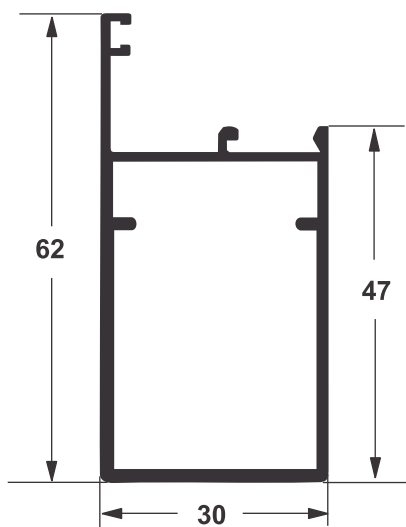

P - 068
0,563 Kg/m

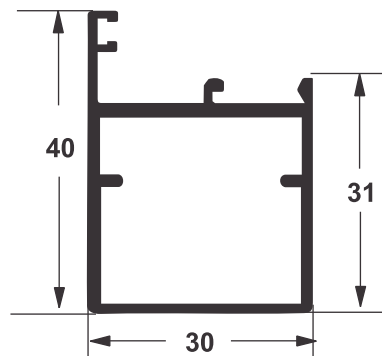

P - 084
0,439 Kg/m

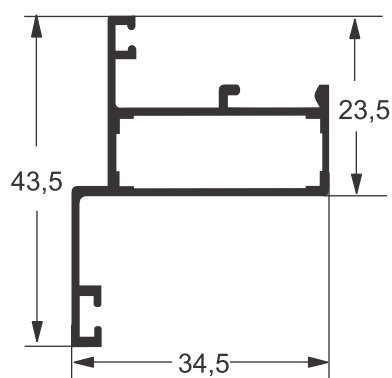

P - 120
0,469 Kg/m

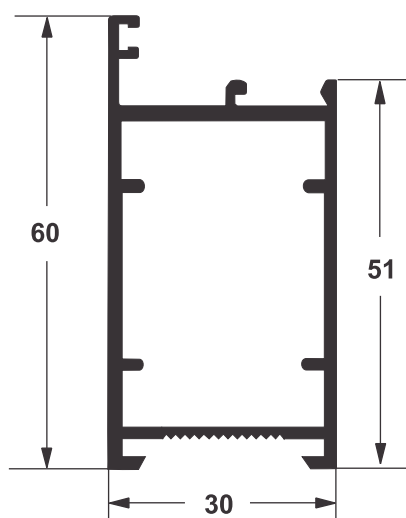

P - 270
0,686 Kg/m

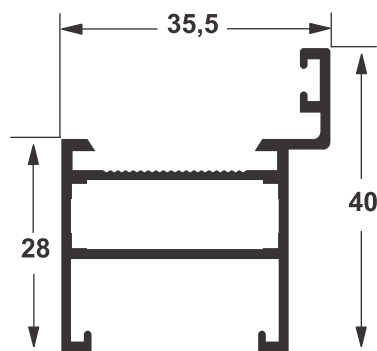

P - 273
0,500 Kg/m

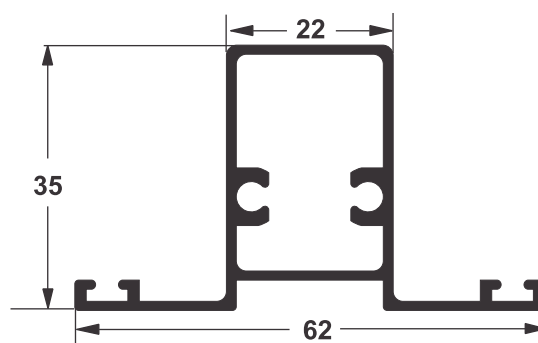

P - 419
0,613 Kg/m

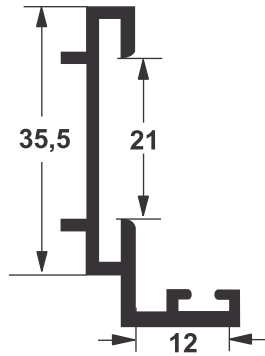

L - 519
0,241 Kg/m

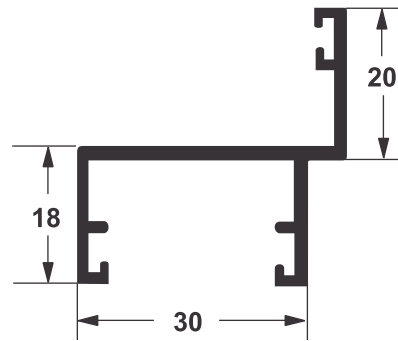

Y - 140
0,363 Kg/m

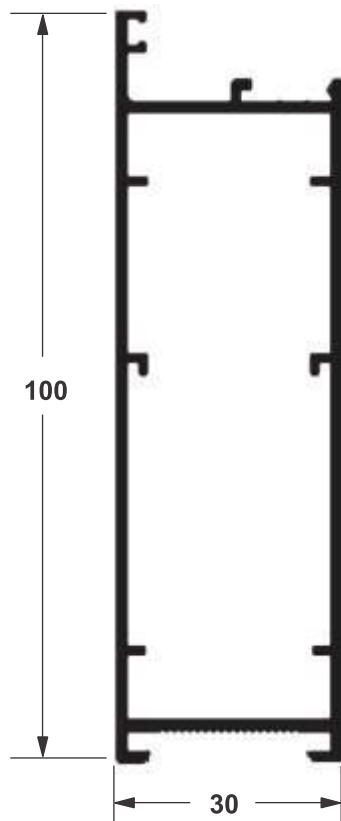

P - 264
1,130 Kg/m

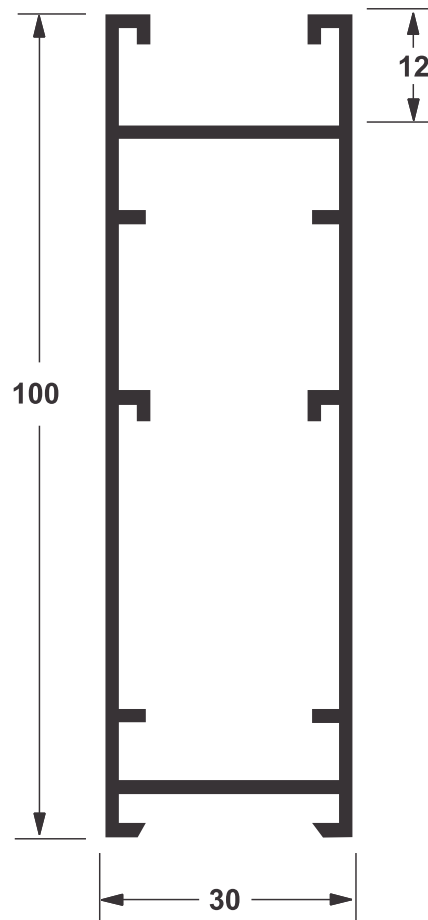

30-001
1,086 Kg/m



LINHA SUPREMA

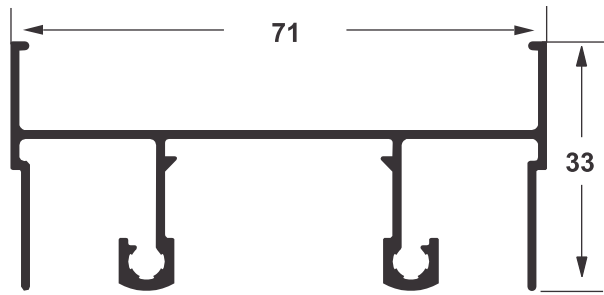

SU - 001
0,701 Kg/m

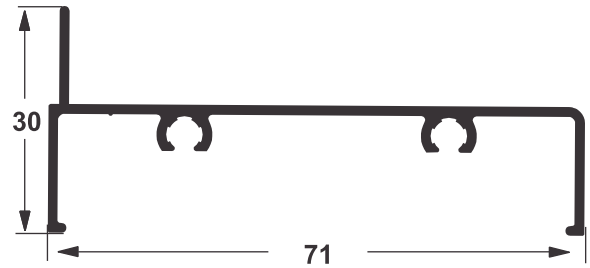

SU - 004
0,484 Kg/m

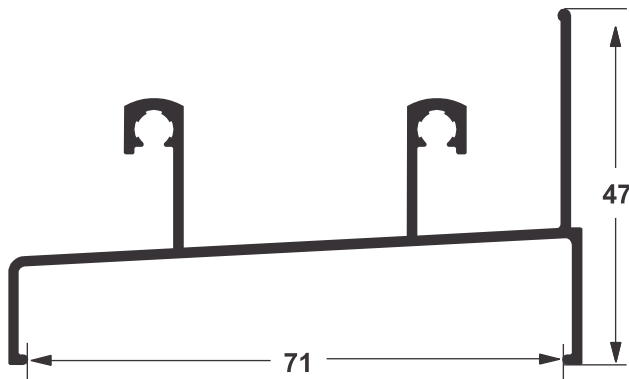

SU - 002
0,682 Kg/m

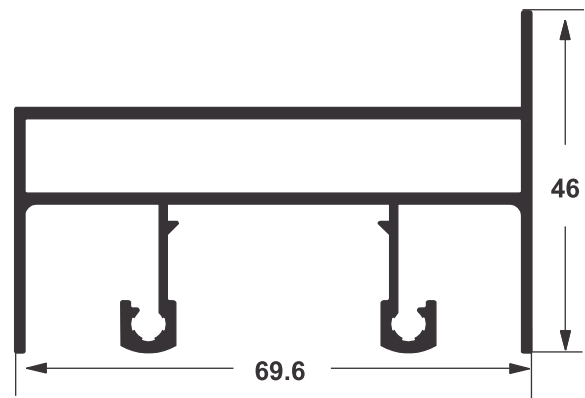

SU - 005
1,002 Kg/m

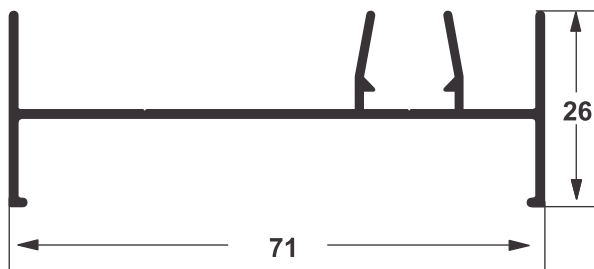

SU - 003
0,533 Kg/m

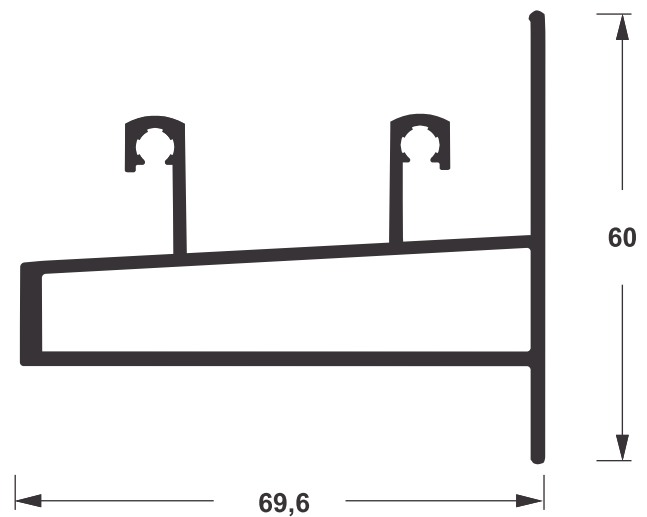

SU - 006
1,008 Kg/m

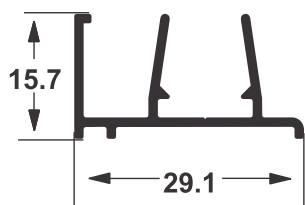

SU - 008
0,233 Kg/m

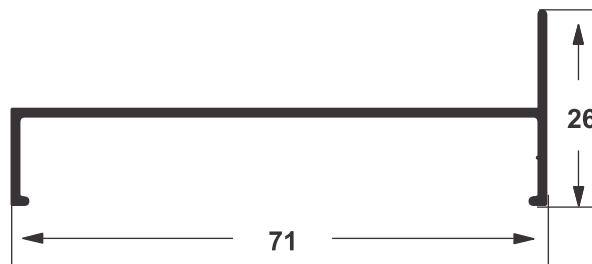

SU- 007
0,413 Kg/m

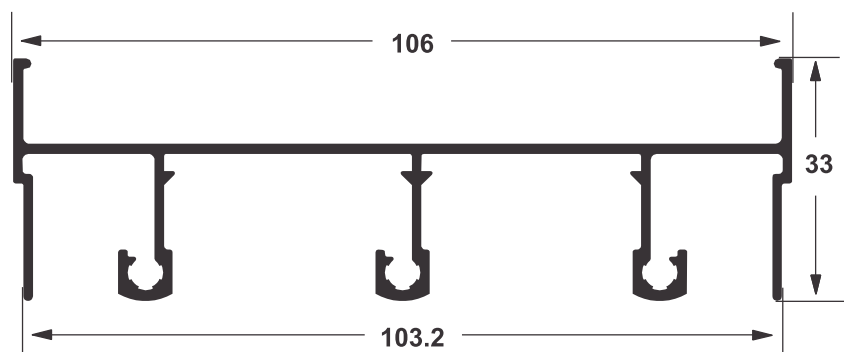

SU - 010
1,021 Kg/m

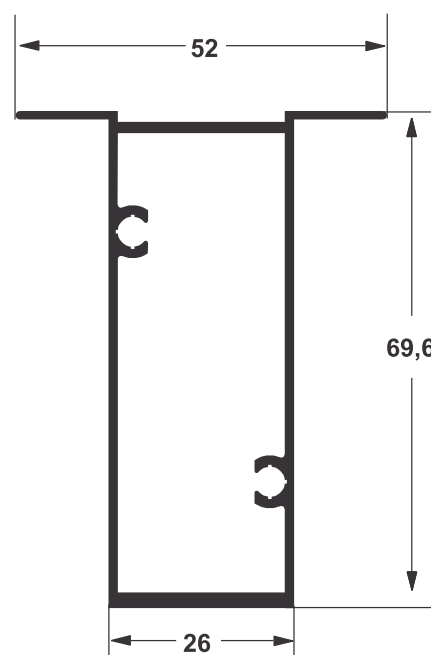

SU - 009
0,967 Kg/m

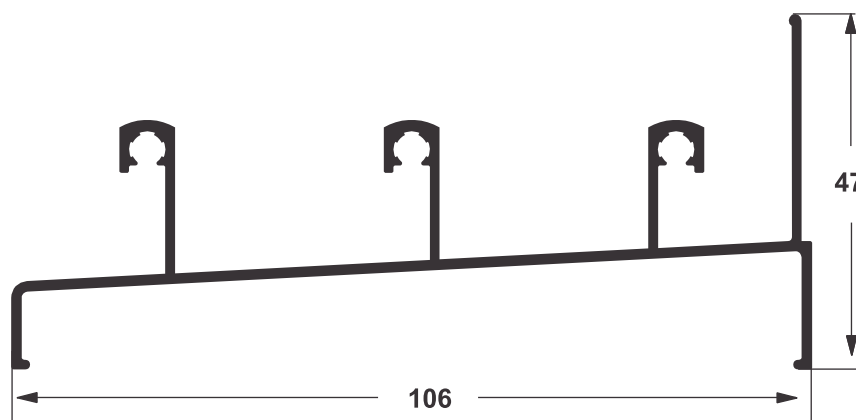

SU - 011
0,989 Kg/m

LINHA SUPREMA

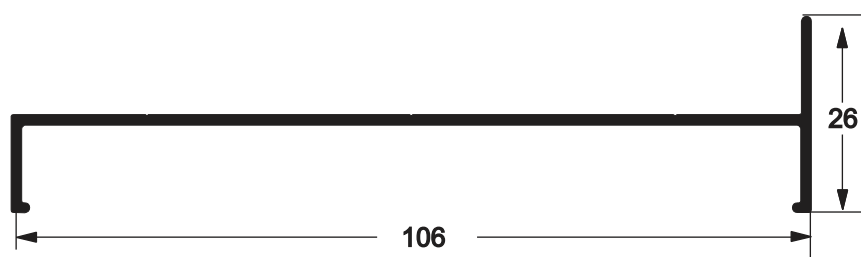

SU - 012
0,536 Kg/m

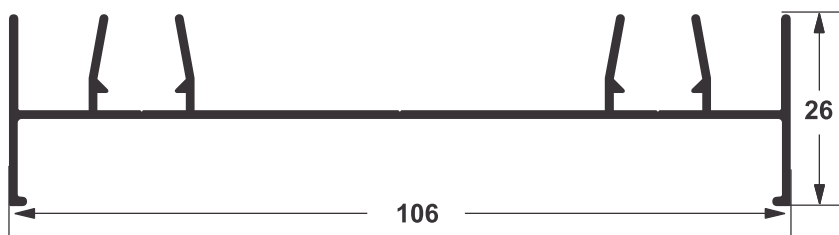

SU - 013
0,710 Kg/m

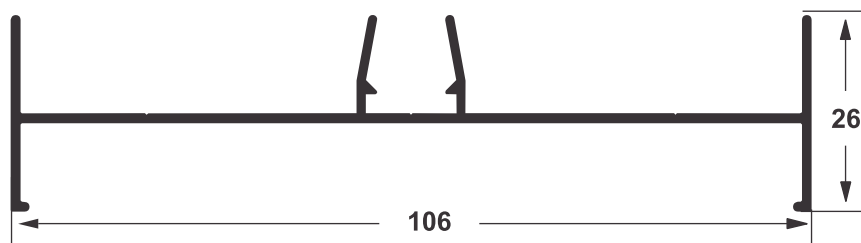

SU - 014
0,587 Kg/m

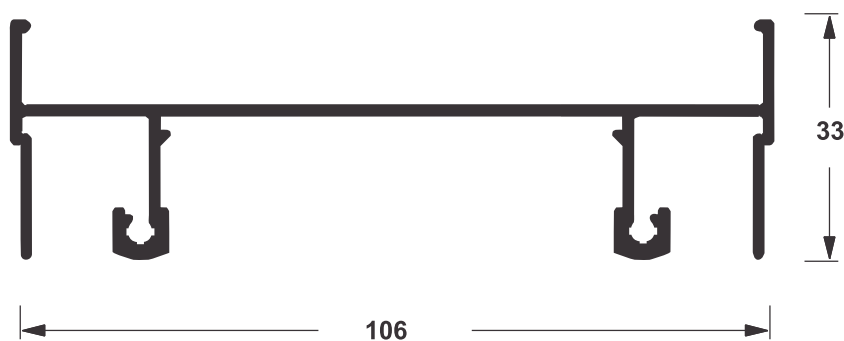

SU - 015
0,587 Kg/m

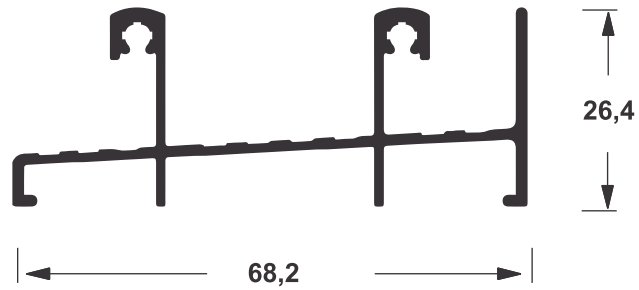

SU - 021
0,694 Kg/m

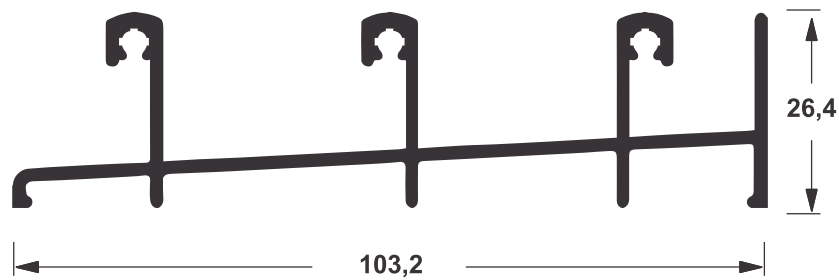

SU - 023
0,752 Kg/m

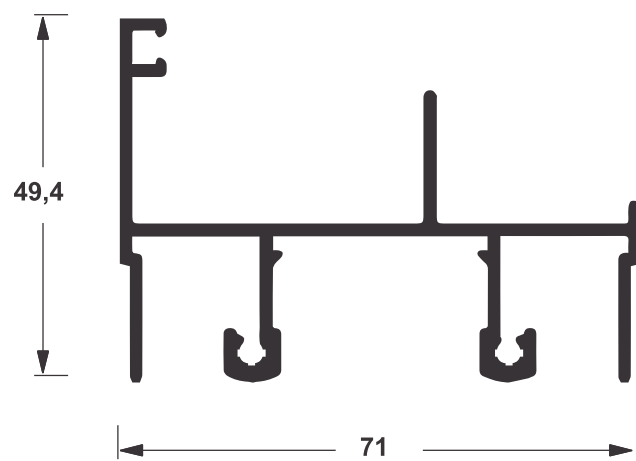

SU - 026
0,903 Kg/m

LINHA SUPREMA

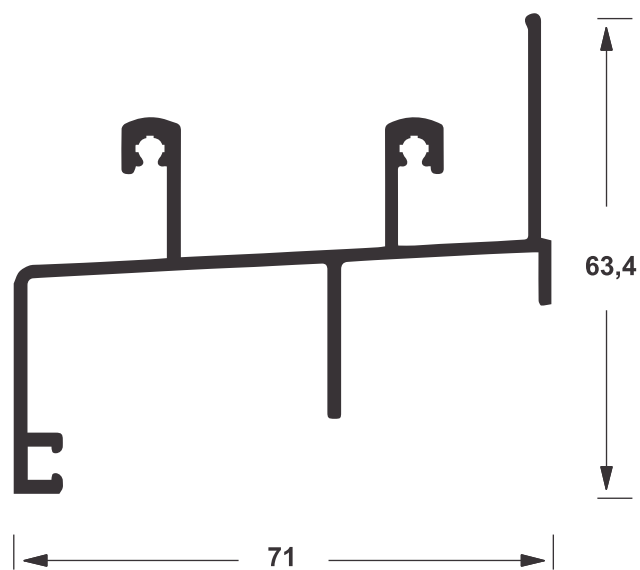

SU - 027
0,824 Kg/m

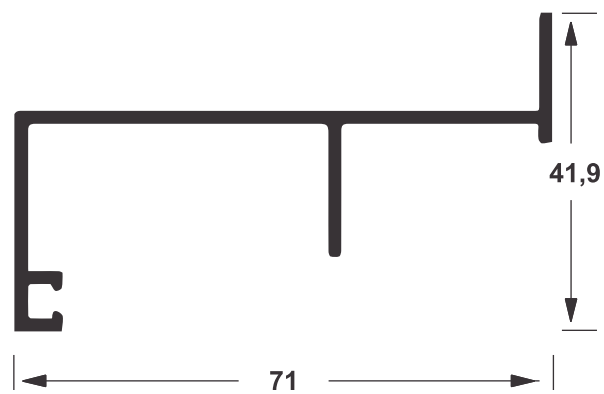

SU - 028
0,516 Kg/m

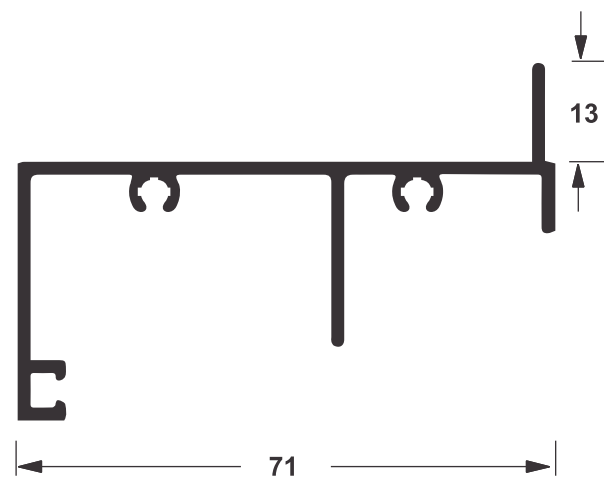

SU - 029
0,541 Kg/m

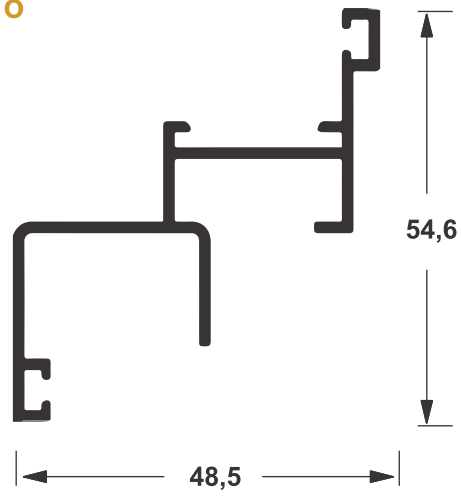

SU - 030
0,530 Kg/m

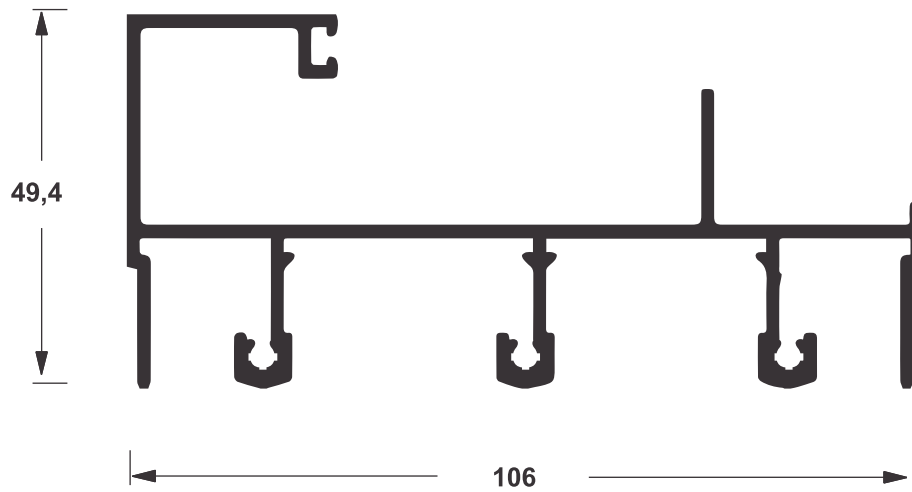

SU - 031
1,317 Kg/m

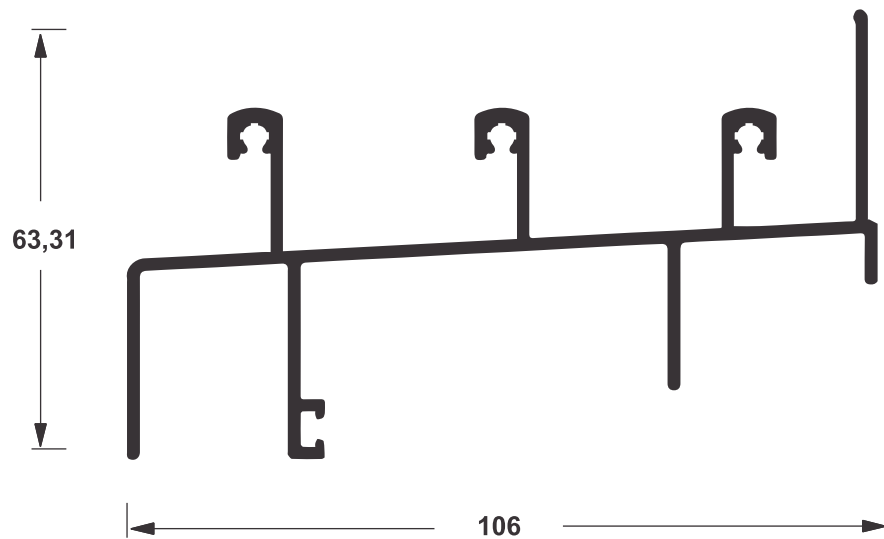

SU - 032
1,109 Kg/m

LINHA SUPREMA

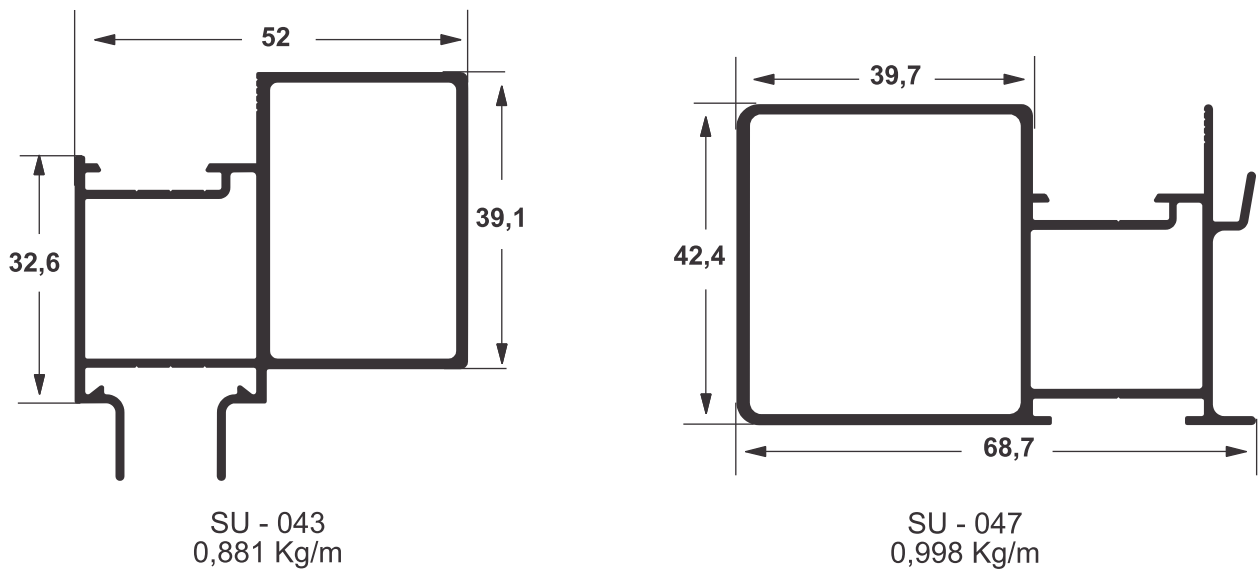
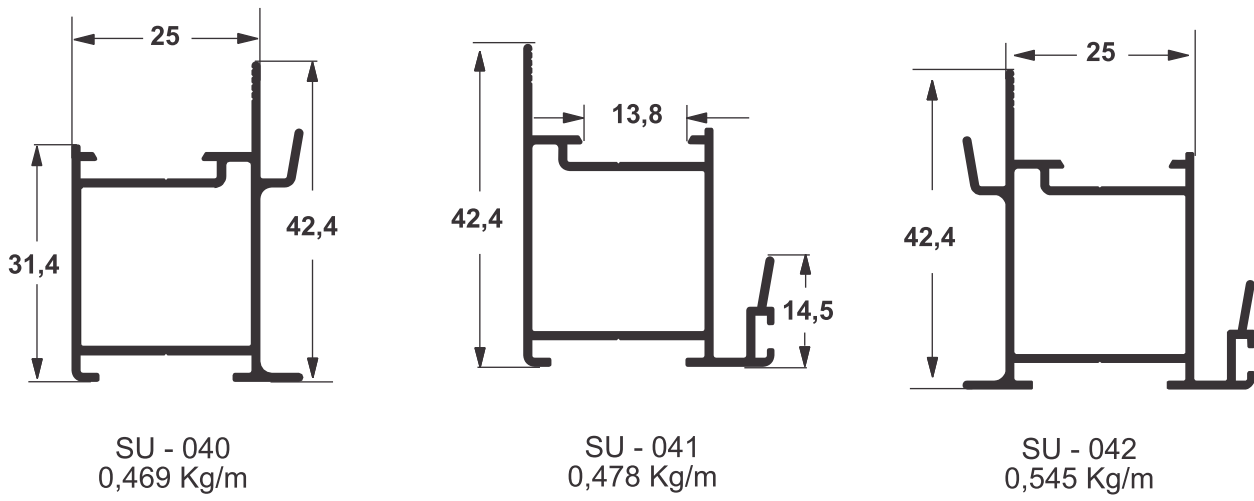
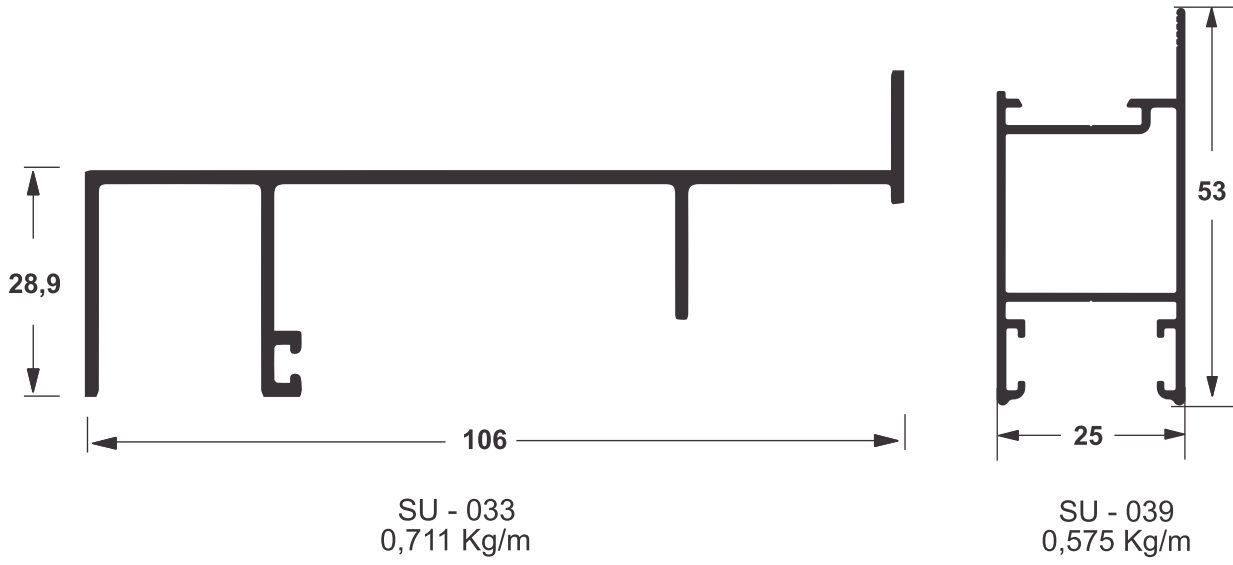

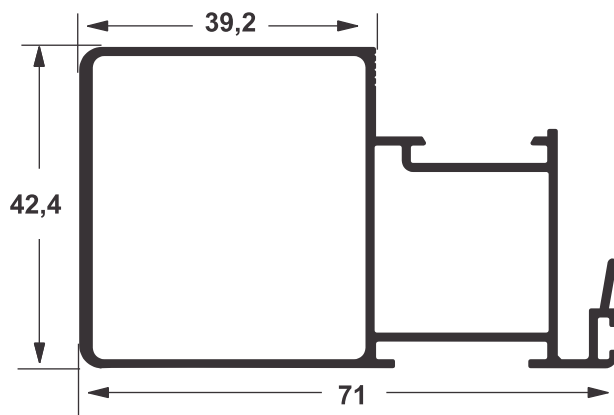

SU - 049
0,913 Kg/m

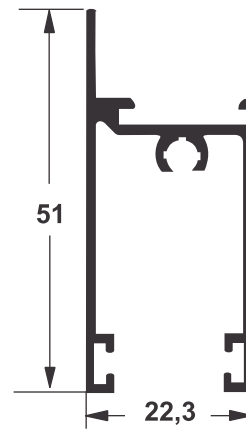

SU - 053
0,489 Kg/m

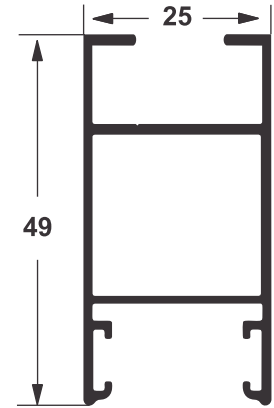

SU - 055
0,517 Kg/m

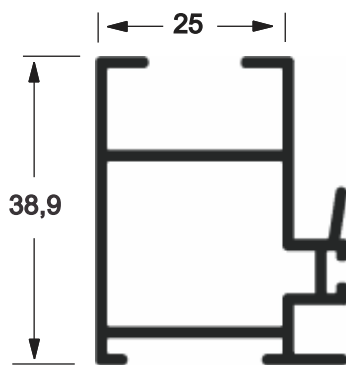

SU - 056
0,560 Kg/m

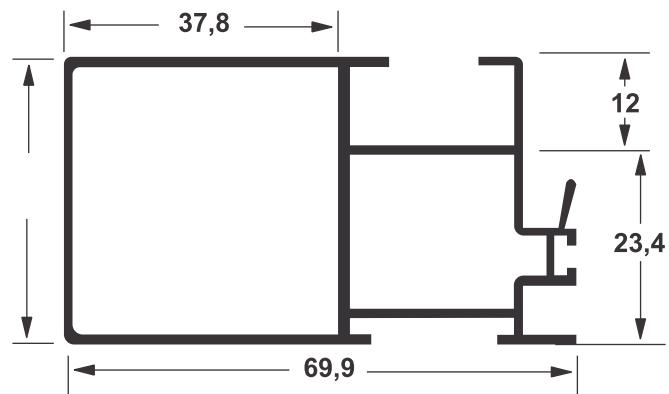

SU - 061
1,060 Kg/m

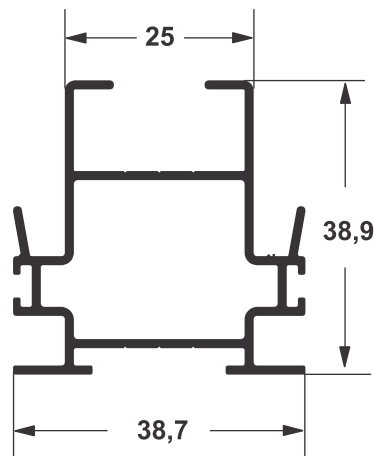

SU - 057
0,650 Kg/m

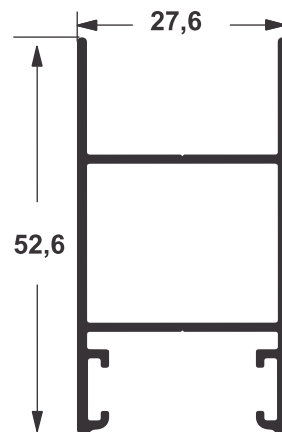

SU - 068
0,551 Kg/m

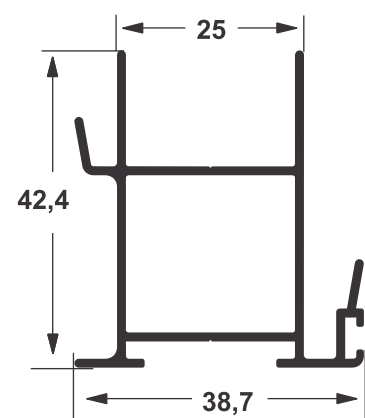

SU - 069
0,539 Kg/m

LINHA SUPREMA

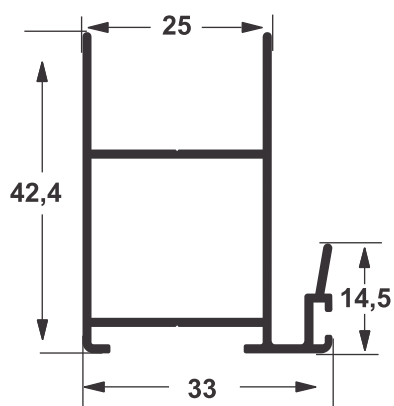

SU - 070
0,485 Kg/m

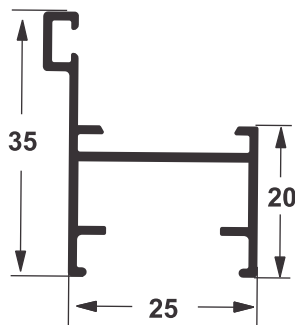

SU - 079
0,342 Kg/m

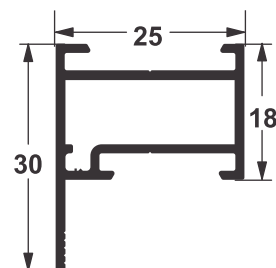

SU - 080
0,343 Kg/m

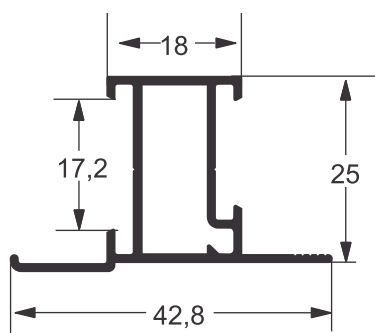

SU - 081
0,340 Kg/m

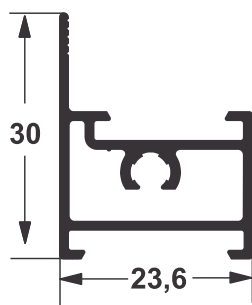

SU - 082
0,386 Kg/m



SU - 083
0,143 Kg/m

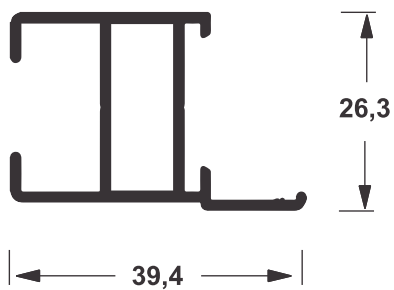

SU - 090
0,379 Kg/m

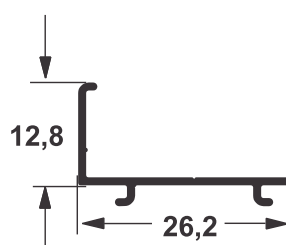

SU - 084
0,126 Kg/m

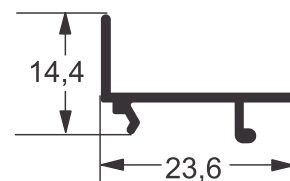

SU - 108
0,151 Kg/m

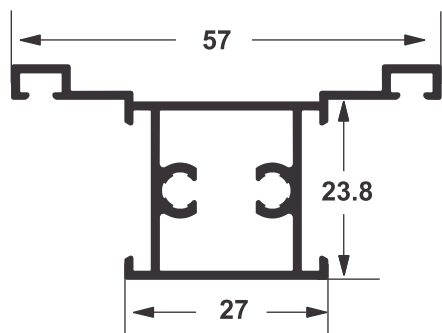

SU - 086
0,628 Kg/m

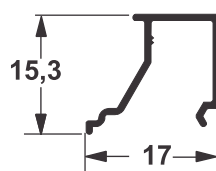

SU - 102
0,104 Kg/m

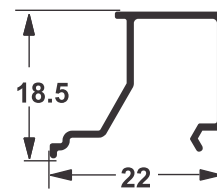

SU - 103
0,137 Kg/m

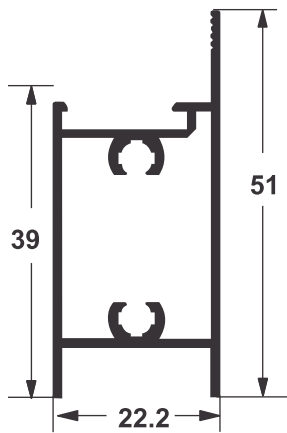

SU - 110
0,501 Kg/m

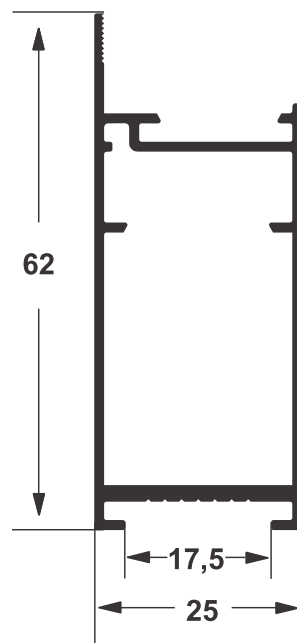

SU - 111
0,618 Kg/m

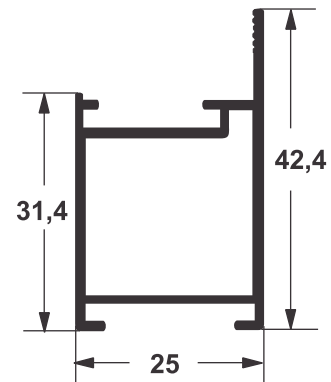

SU - 120
0,401 Kg/m

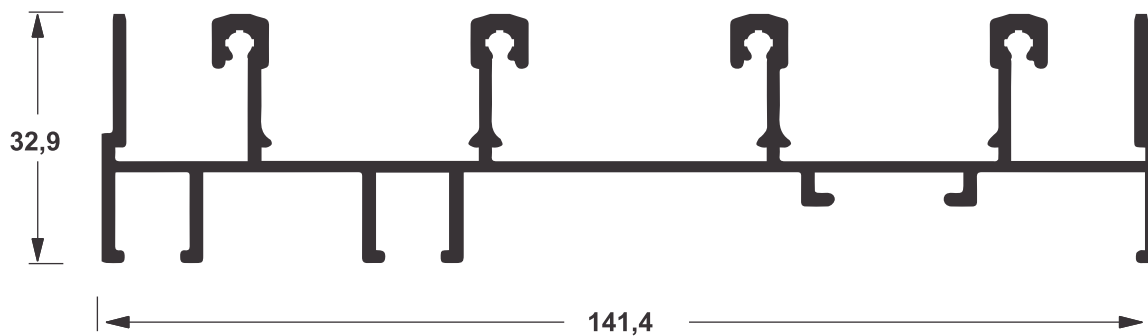

SU - 121
1,460 Kg/m

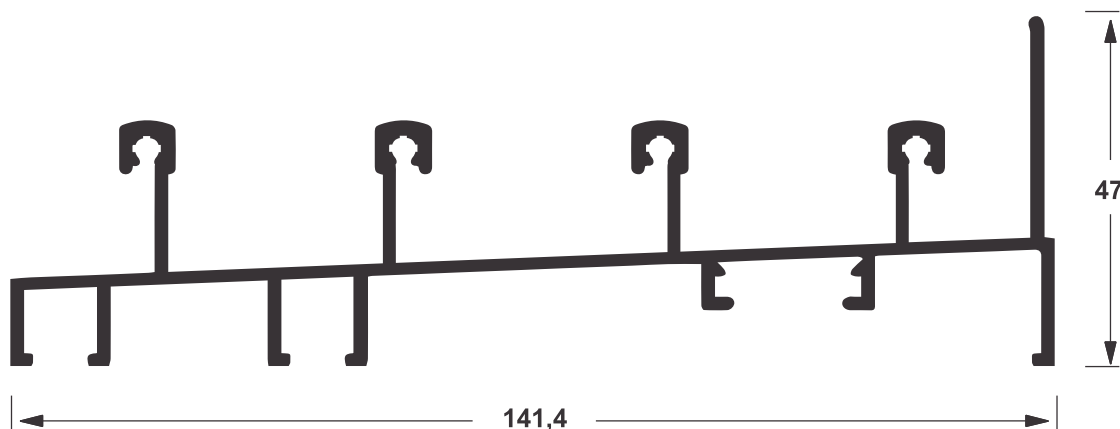

SU - 122
1,471 Kg/m

LINHA SUPREMA

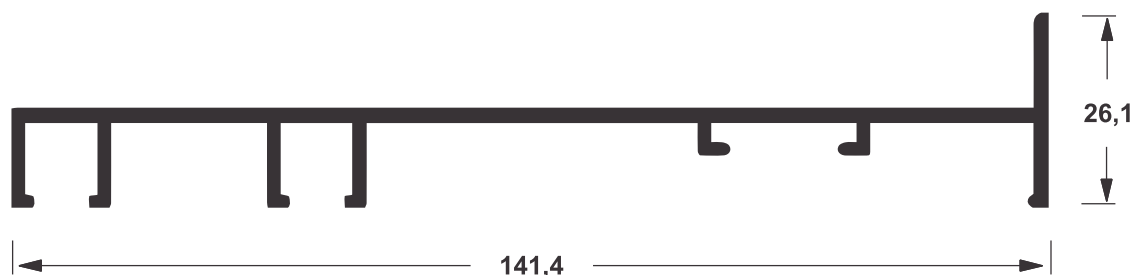

SU - 123
0,996 Kg/m

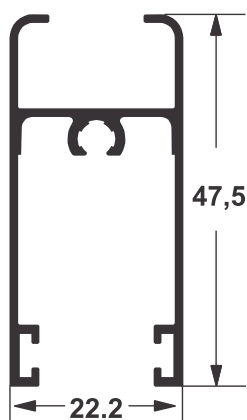

SU - 186
0,467 Kg/m

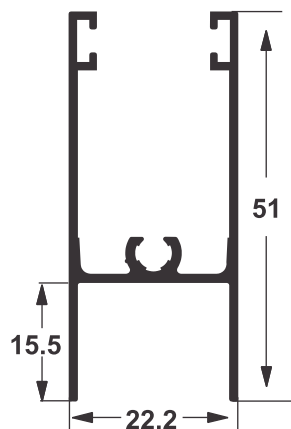

SU - 187
0,485 Kg/m

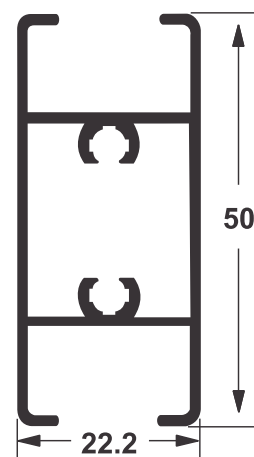

SU - 188
0,575 Kg/m

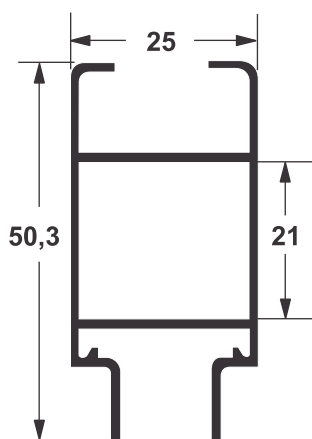

SU - 190
0,502 Kg/m

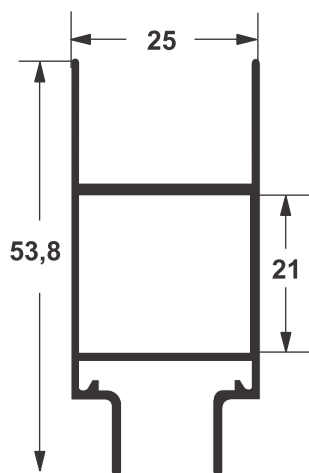

SU - 191
0,455 Kg/m

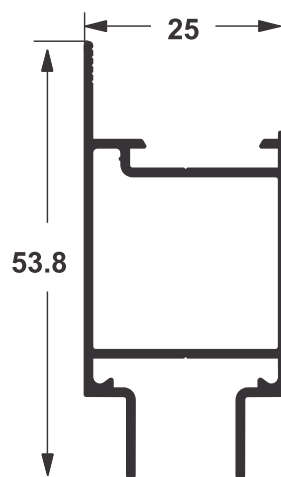

SU - 192
0,492 Kg/m

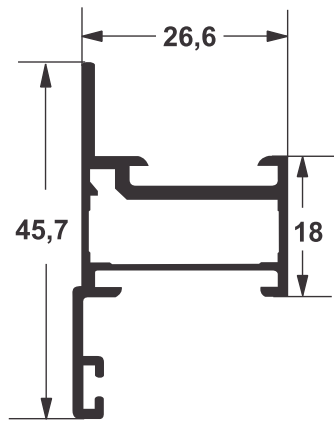

SU - 200
0,398 Kg/m

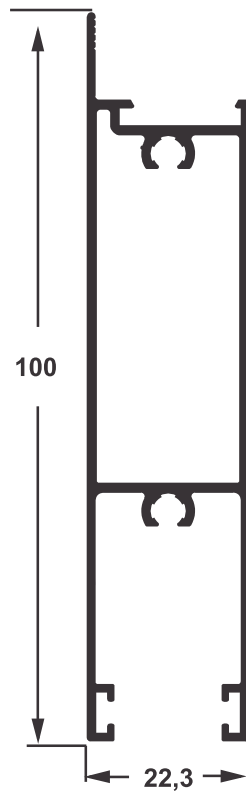

SU - 225
0,999 Kg/m

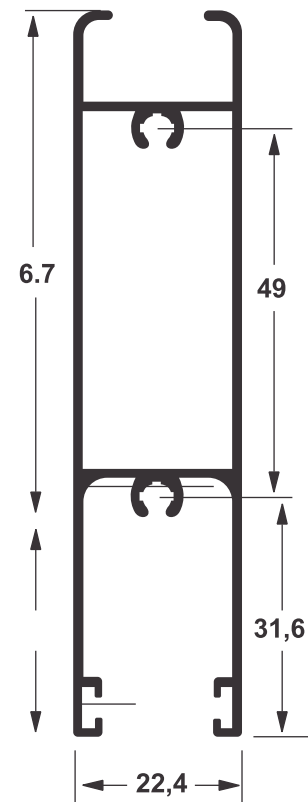

SU - 226
1,014 Kg/m

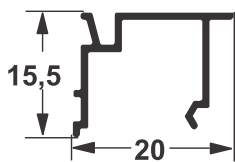

SU - 203
0,137 Kg/m

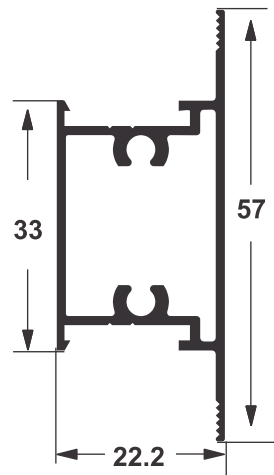

SU - 227
0,548 Kg/m

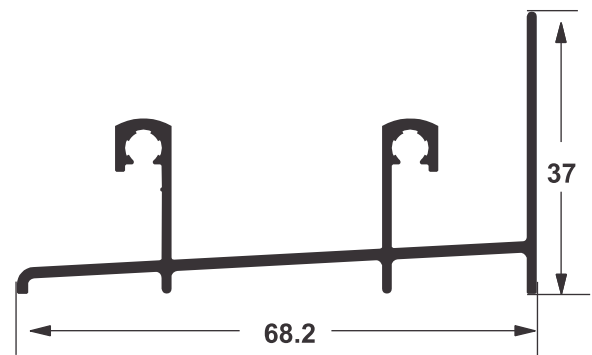

SU - 228
0,666 Kg/m

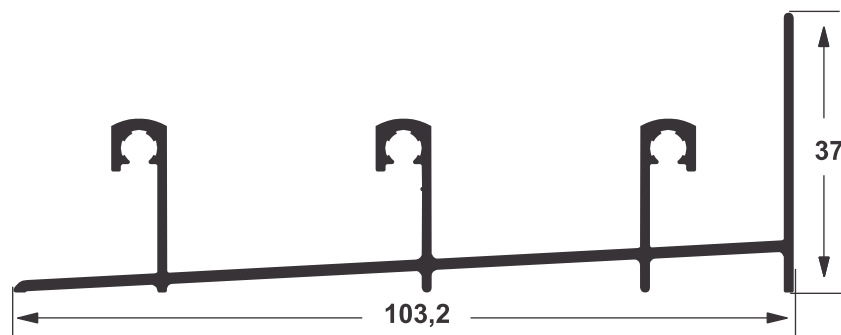

SU - 230
0,899 Kg/m

LINHA SUPREMA

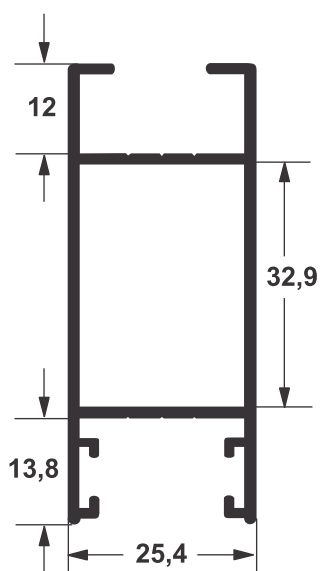

SU - 238
0,624 Kg/m

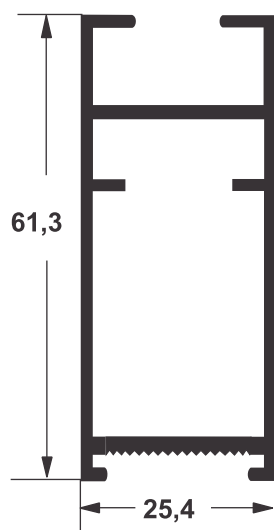

SU - 241
0,567 Kg/m

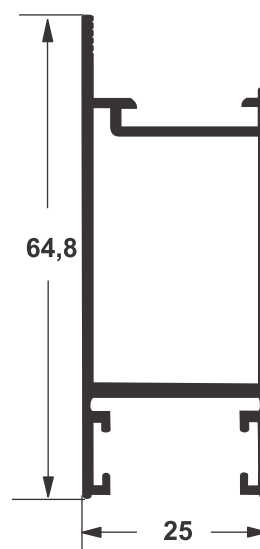

SU - 245
0,597 Kg/m

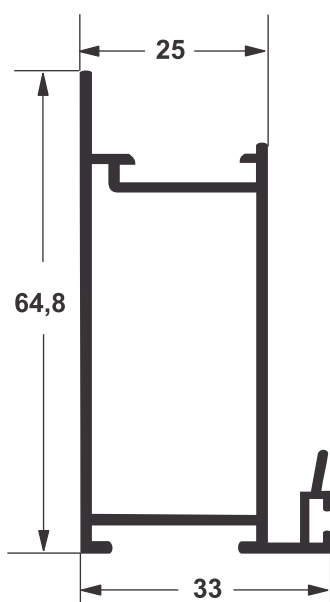

SU - 242
0,660 Kg/m

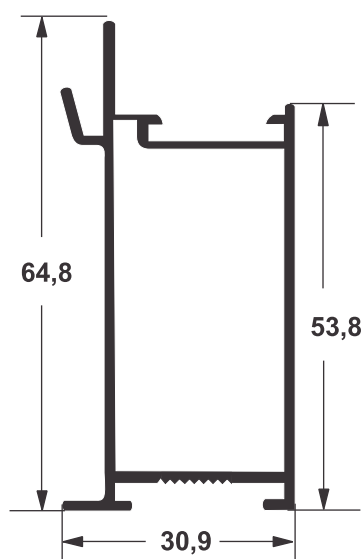

SU - 243
0,618 Kg/m

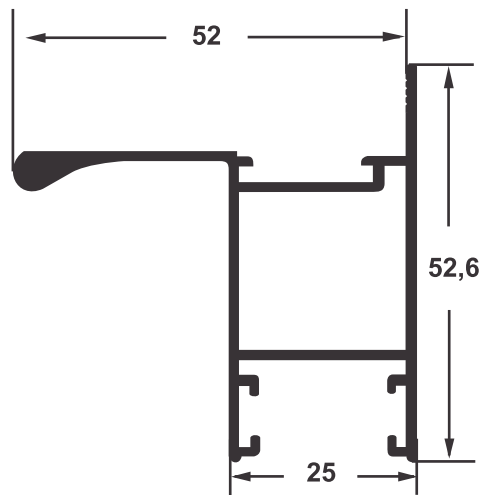

SU - 250
0,623 Kg/m

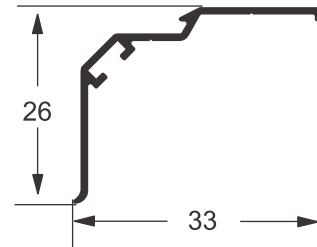

SU - 276
0,155 Kg/m

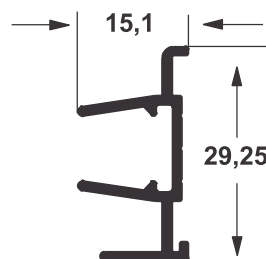

SU - 302
0,225 Kg/m

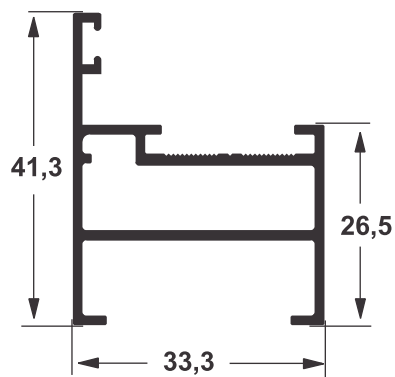

SU - 279
0,522 Kg/m

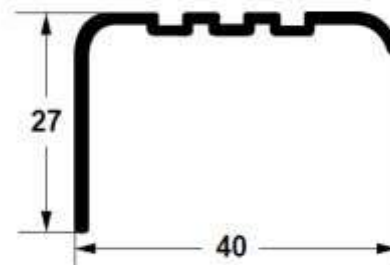

ME - 013
0,217 Kg/m

LINHA GOLD

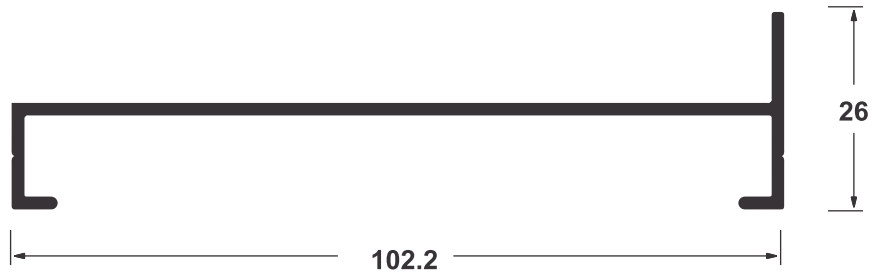

LG - 002
0,632 Kg/m

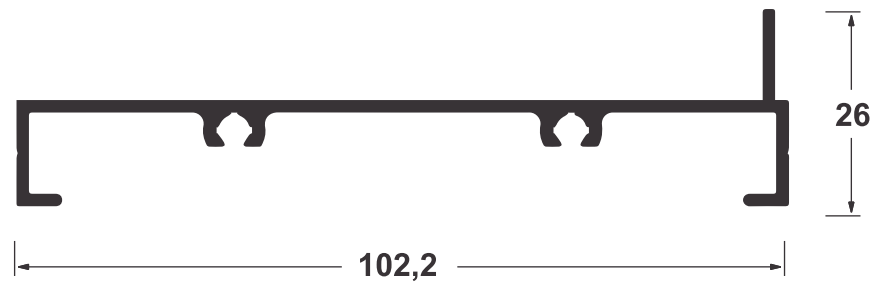

LG - 003
0,754 Kg/m

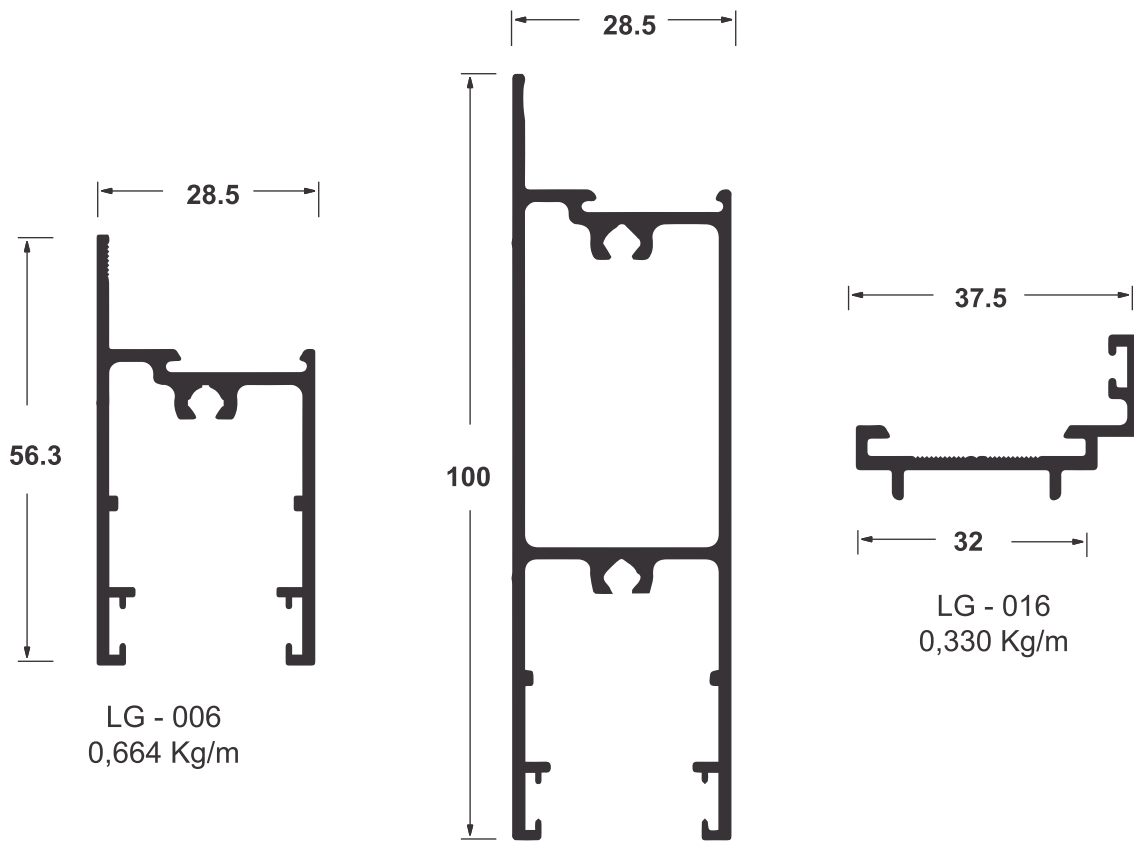

LG - 006
0,664 Kg/m

LG - 007
1,200 Kg/m

LG - 016
0,330 Kg/m

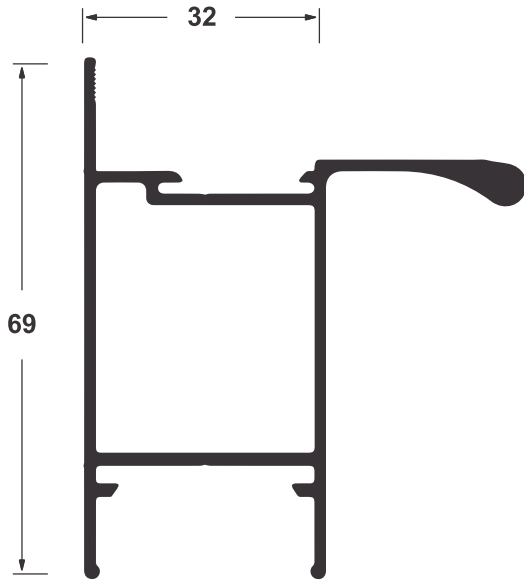

LG - 017
0,995 Kg/m

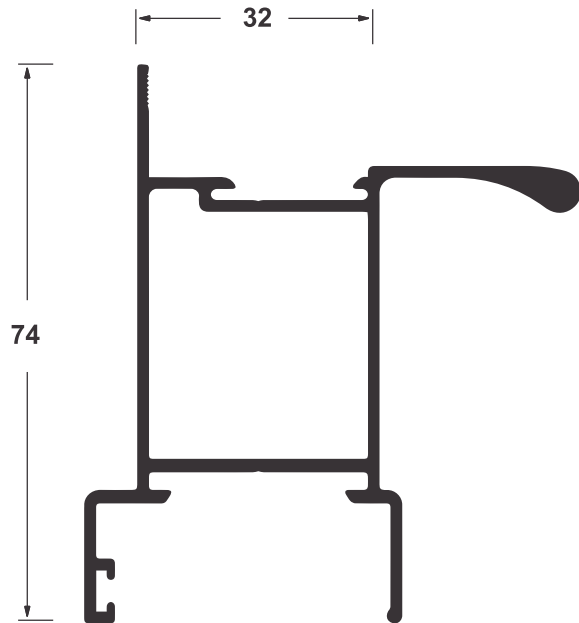

LG - 020
1,119 Kg/m

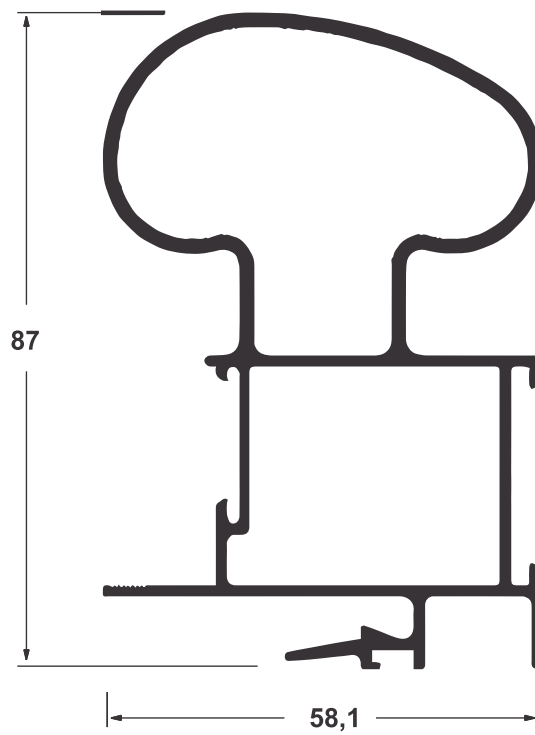

LG - 021
1,782 Kg/m

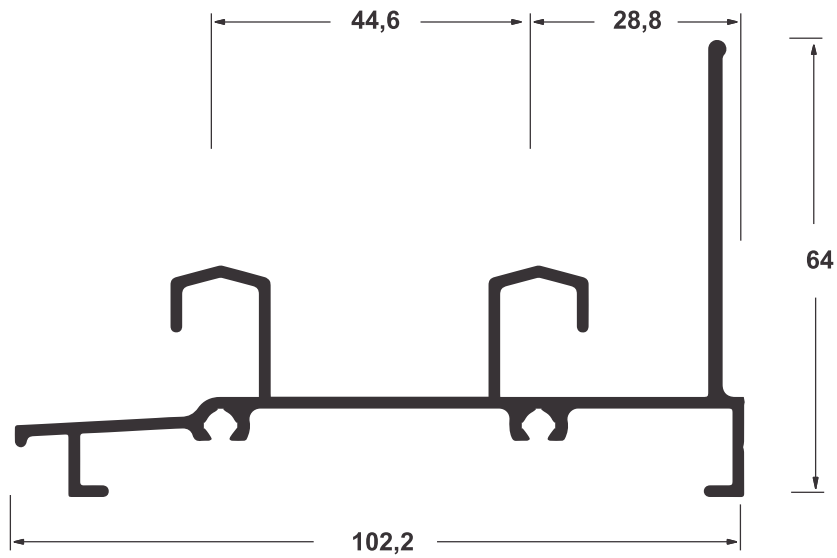

LG - 024
1,143 Kg/m

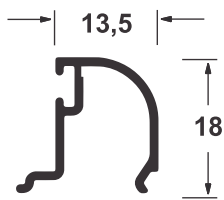

LG - 026
0,150 Kg/m

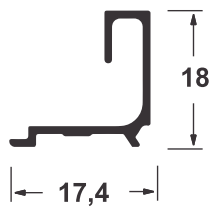

LG - 027
0,144 Kg/m

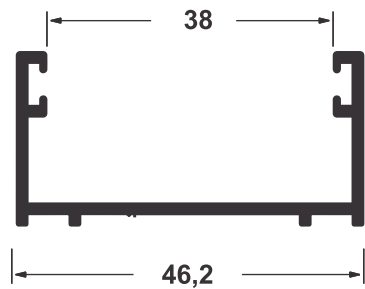

LG - 028
0,464 Kg/m

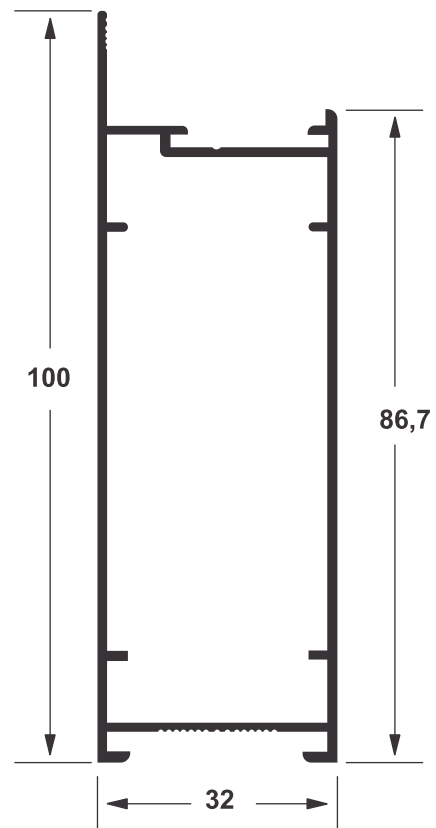

LG - 042
0,959 Kg/m

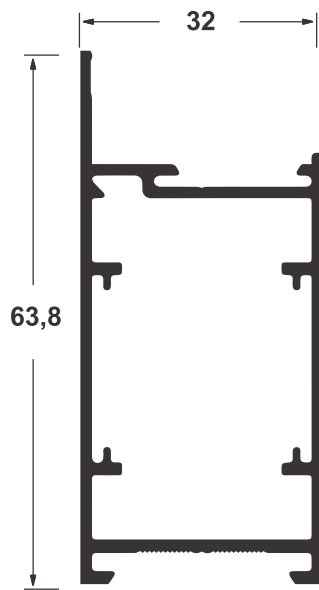

LG - 043
0,933 Kg/m

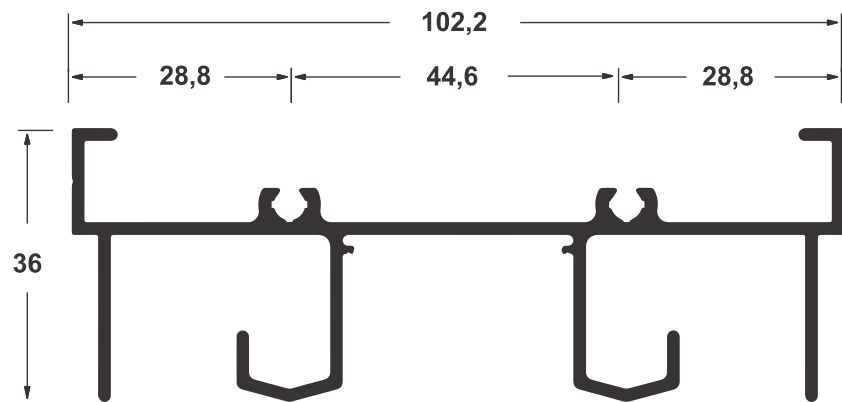

LG - 044
1,230 Kg/m

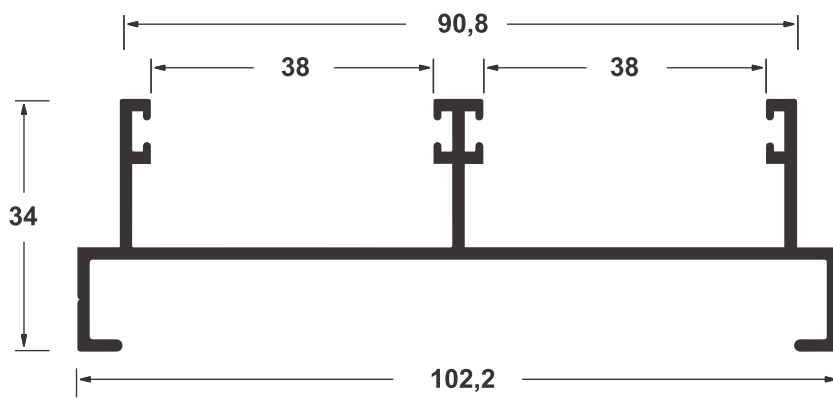

LG - 045
0,651 Kg/m

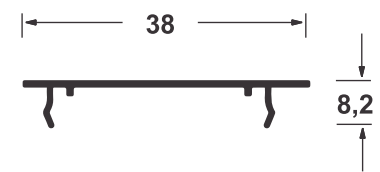

LG - 046
0,204 Kg/m

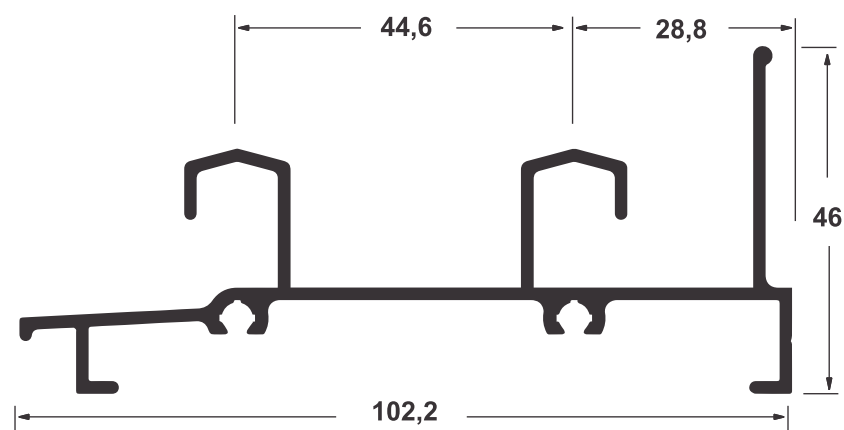

LG - 047
1,165 Kg/m

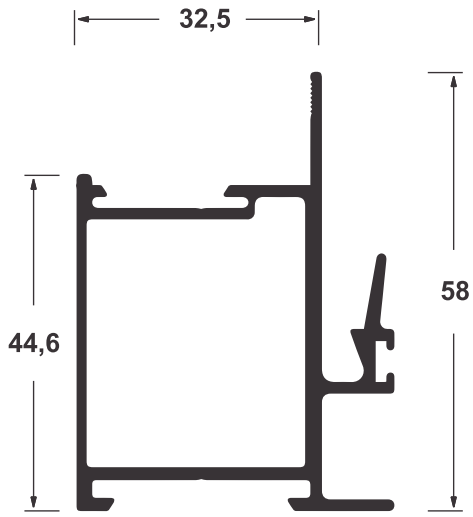

LG - 048
0,959 Kg/m

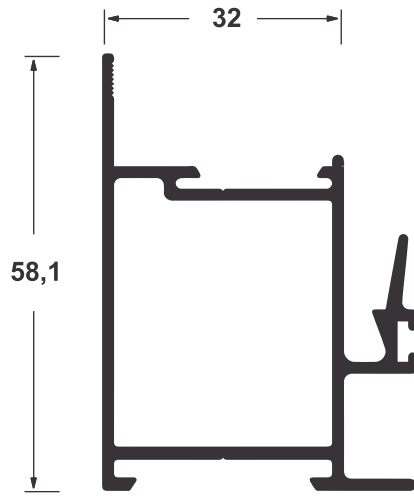

LG - 049
0,937 Kg/m

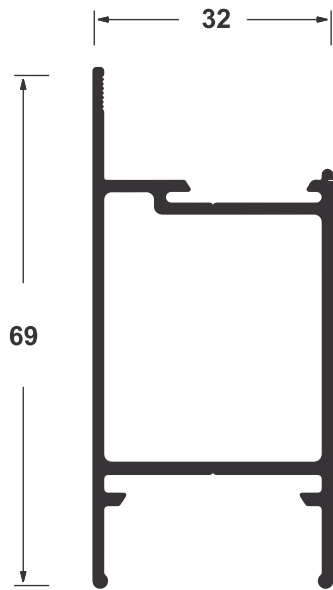

LG - 050
0,787 Kg/m

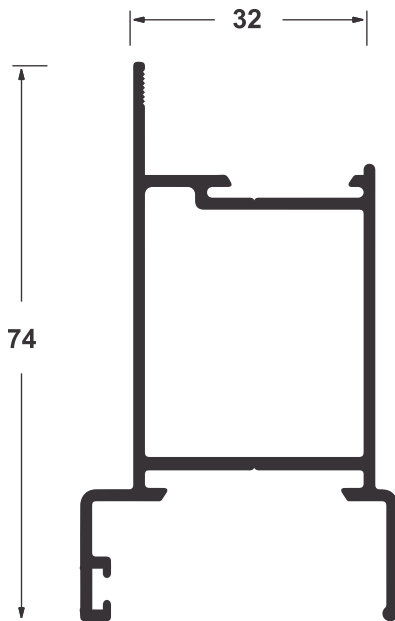

LG - 051
0,900 Kg/m

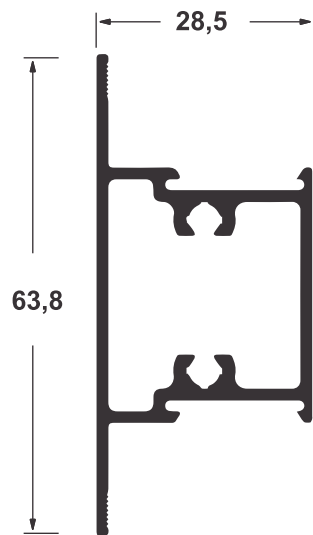

LG - 055
0,757 Kg/m

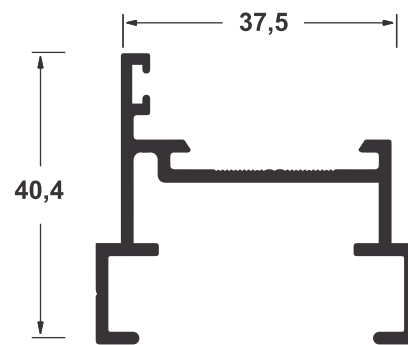

LG - 056
0,652 Kg/m

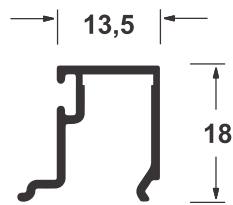

LG - 057
0,164 Kg/m

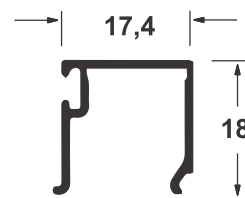

LG - 059
0,174 Kg/m

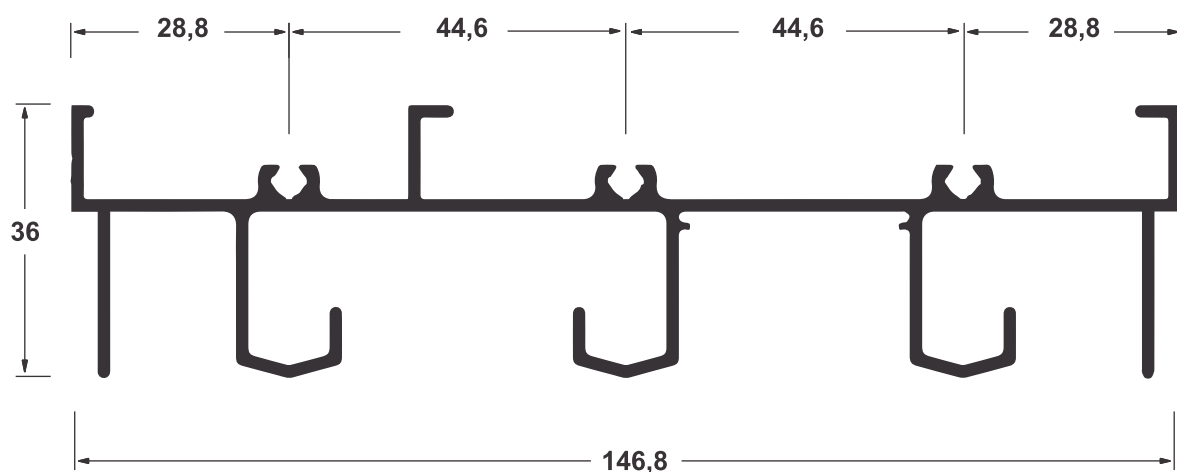

LG- 062
1,780 Kg/m



LINHA GOLD

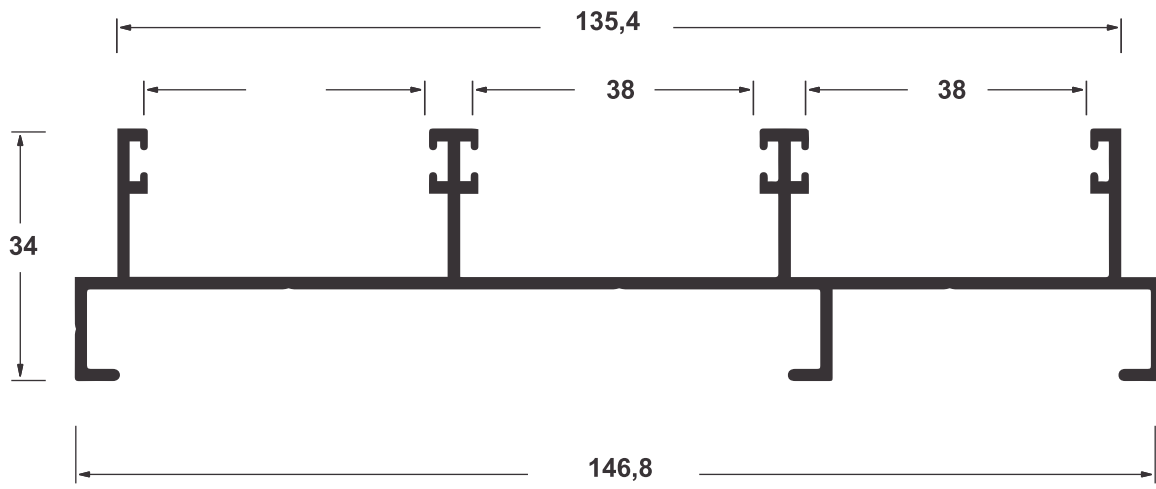

LG - 064
1,282 Kg/m

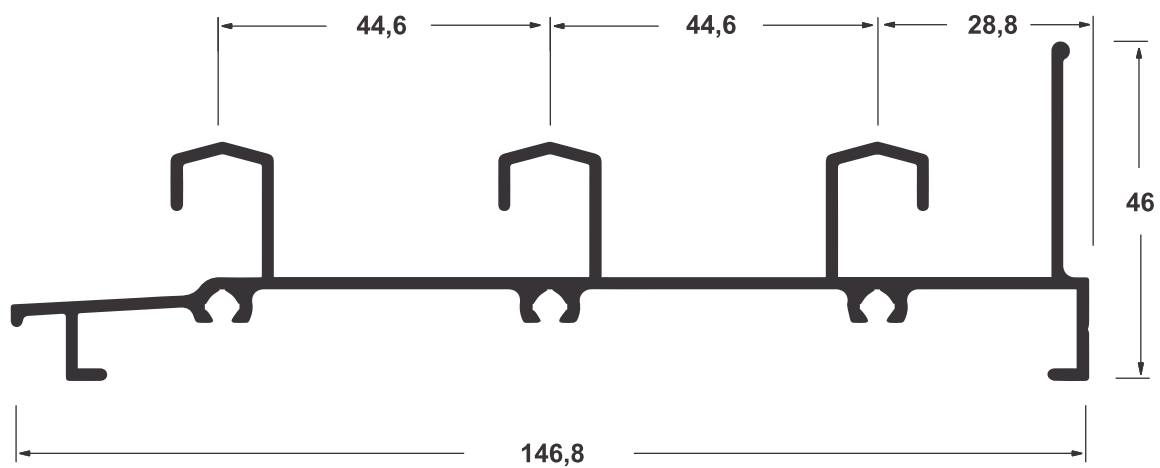

LG - 066
1,455 Kg/m

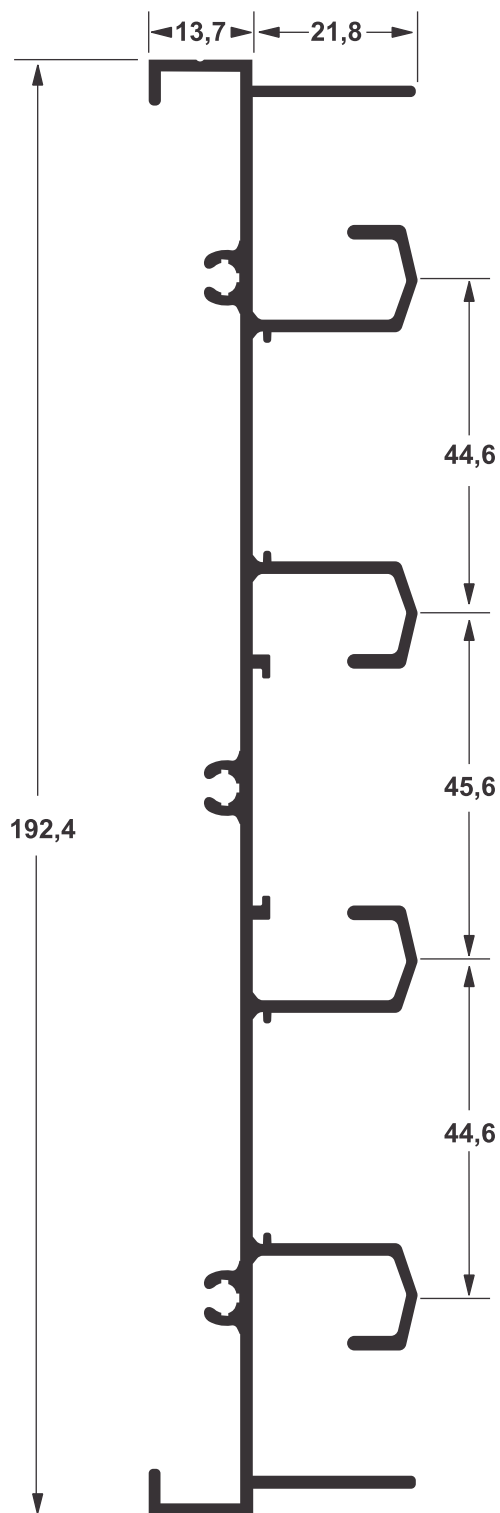

LG - 070
2,075 Kg/m

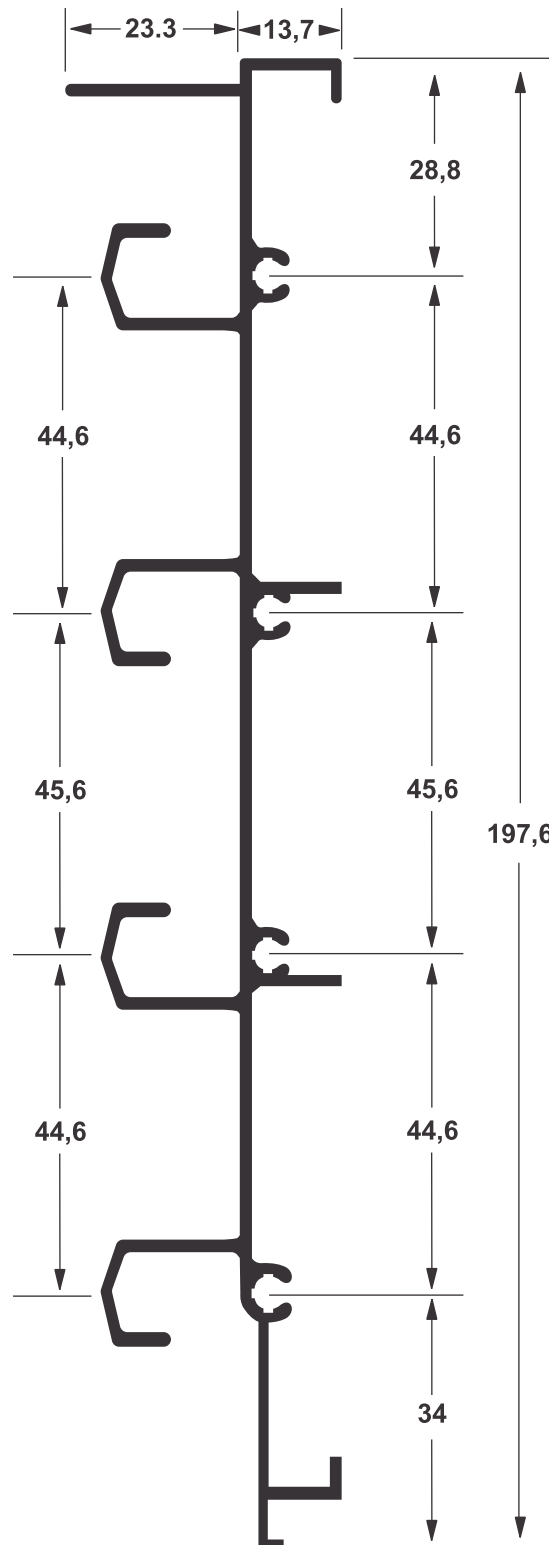

LG - 071
1,962 Kg/m

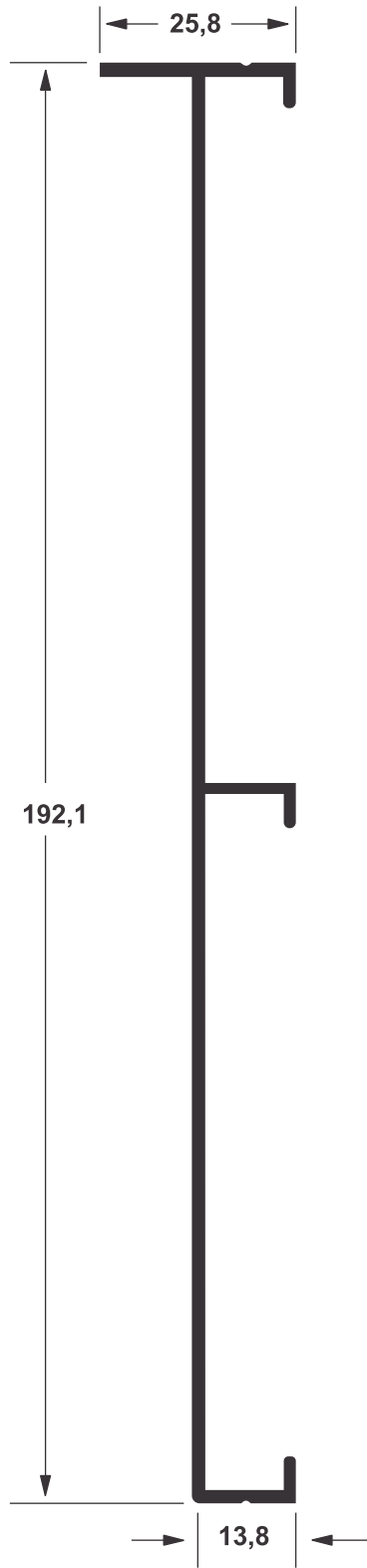

LG - 072
1,098 Kg/m

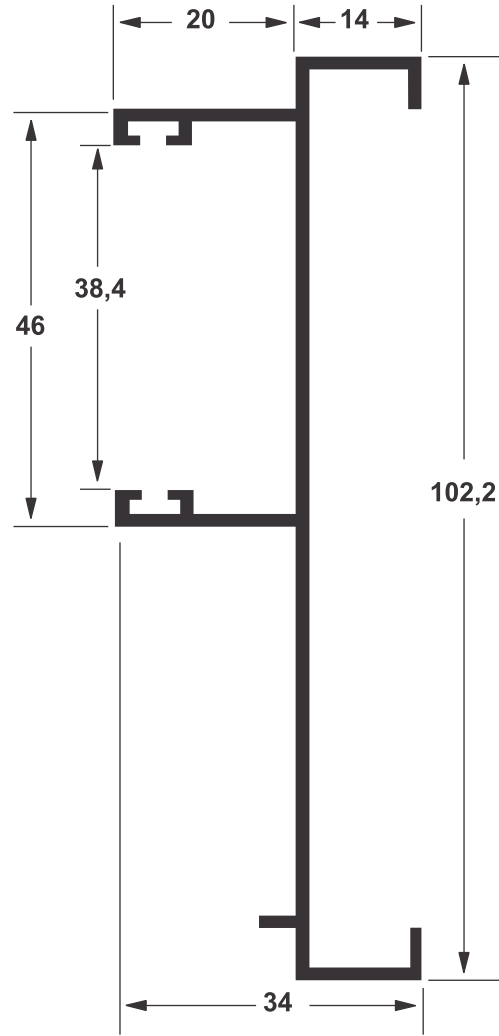

LG - 124
0,773 Kg/m

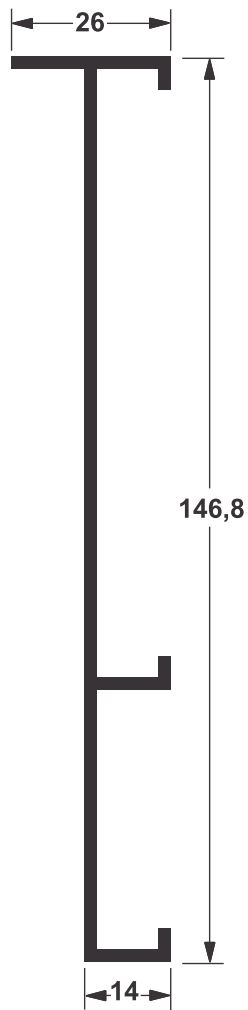

LG - 158
0,876 Kg/m

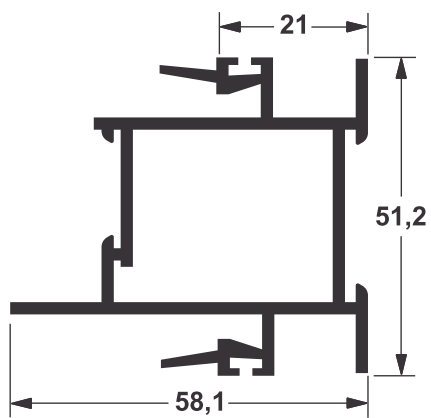

LG - 162
1,074 Kg/m

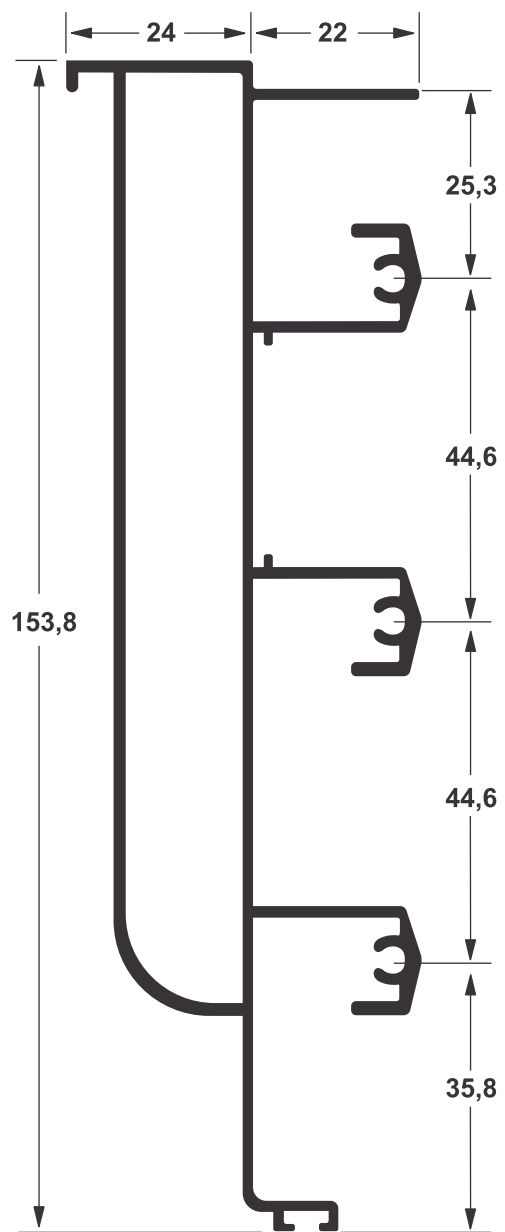

80 - 034
2,141 Kg/m

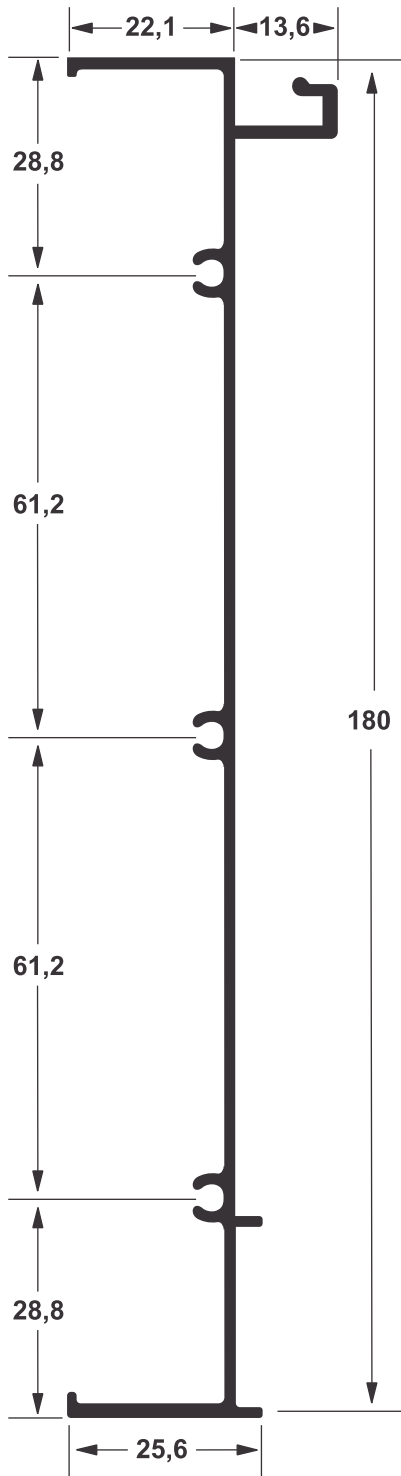

80 - 041
1,370 Kg/m

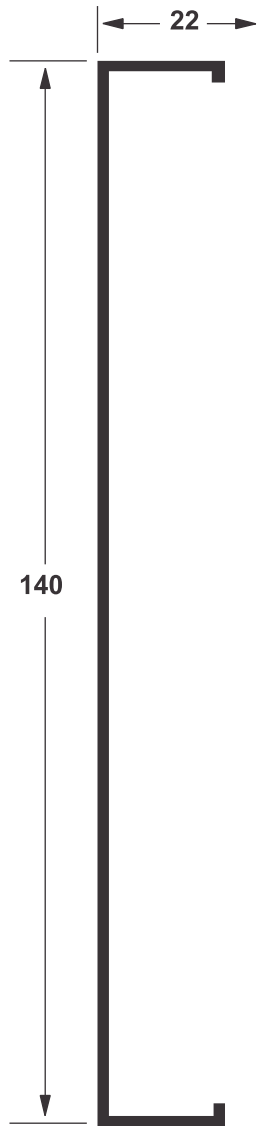

80 - 058
0,751 Kg/m

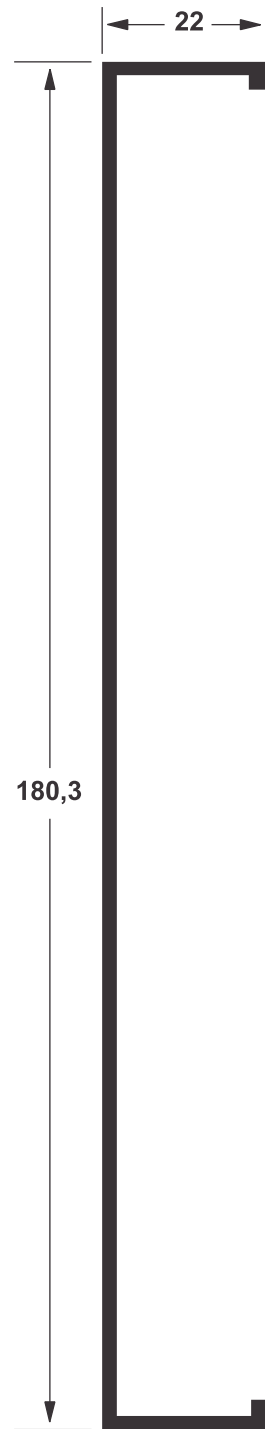

80 - 035
1,090 Kg/m

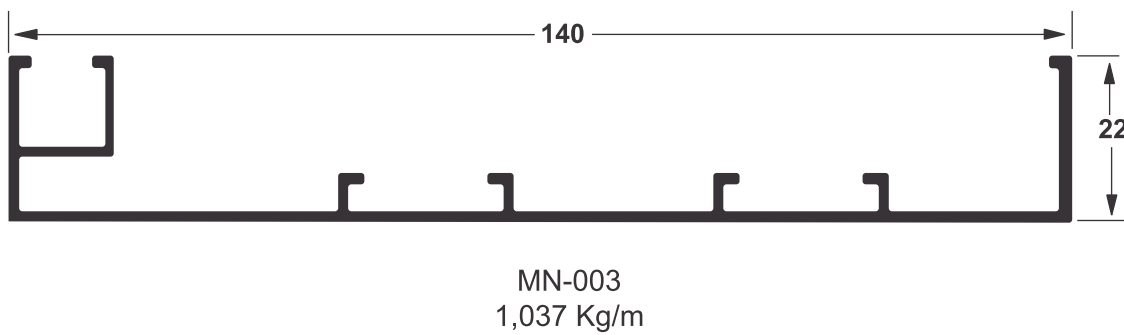
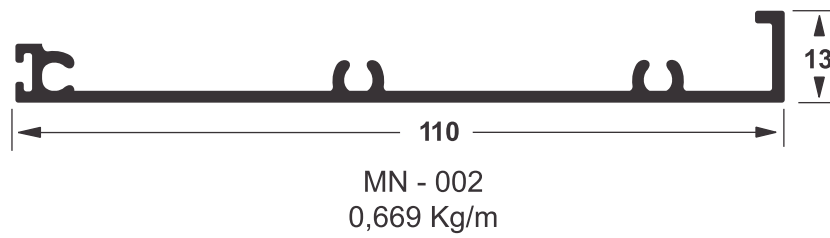
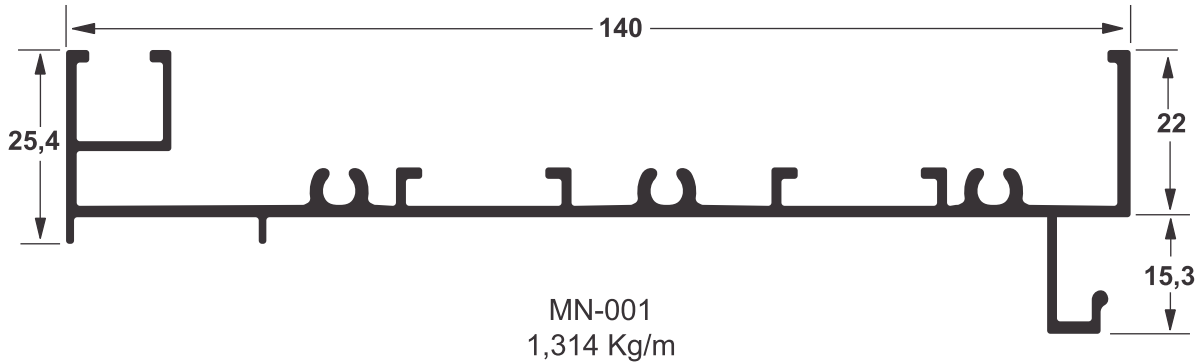

LINHA INTEGRADA

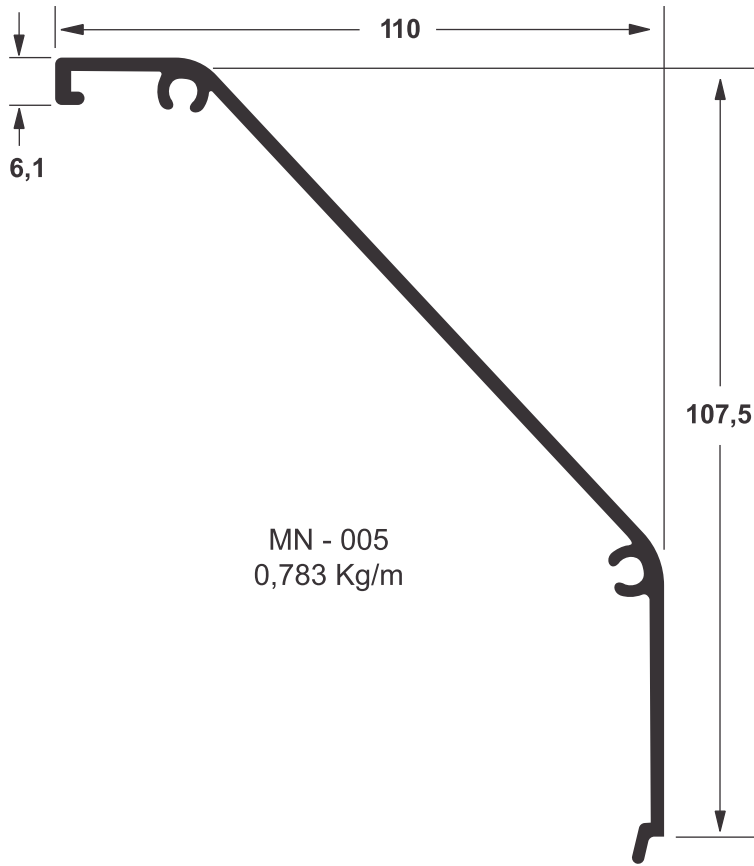

MN - 005
0,783 Kg/m

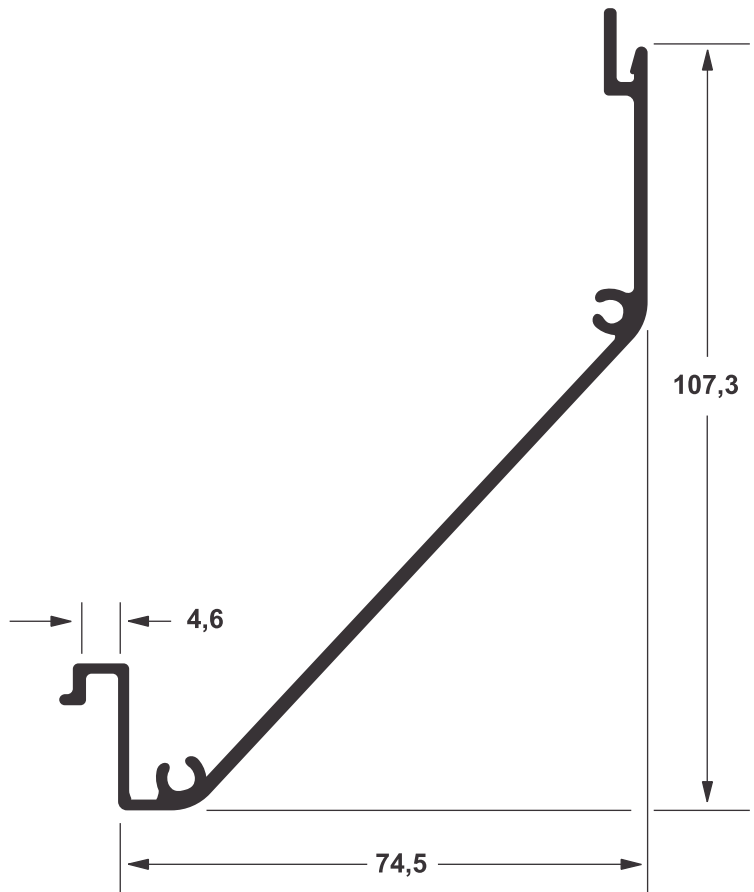

MN - 006
0,878 Kg/m

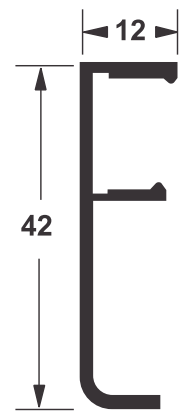

MN - 014
0,214 Kg/m

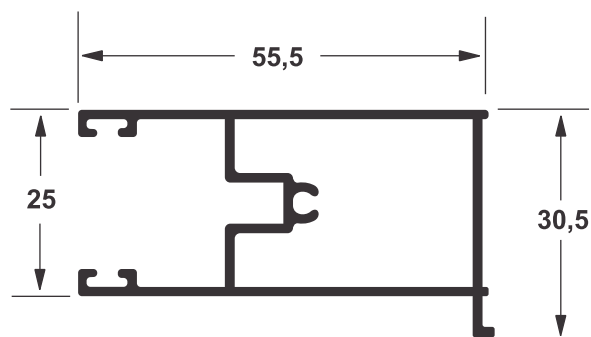

MN - 007
0,707 Kg/m

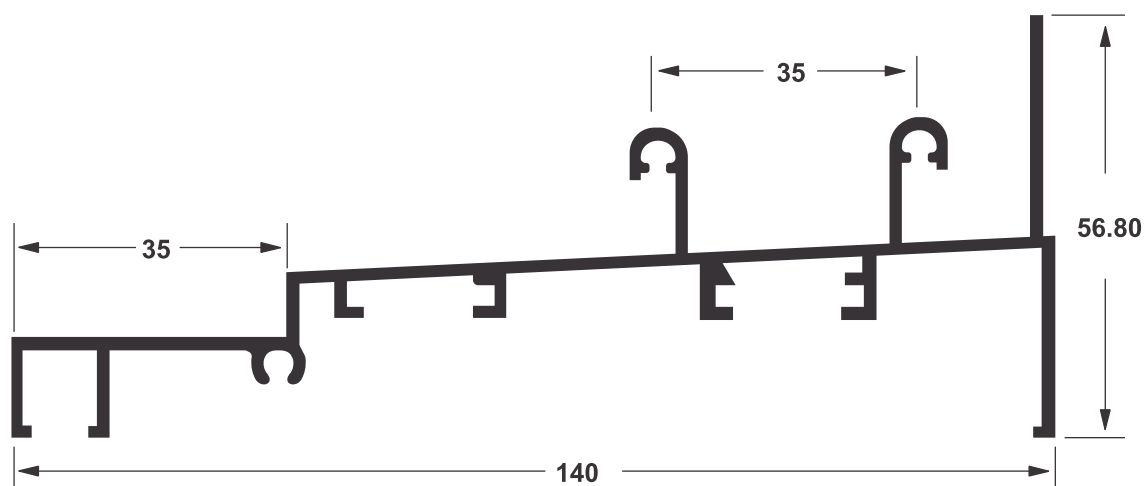

MN - 010
1.420 kg/m

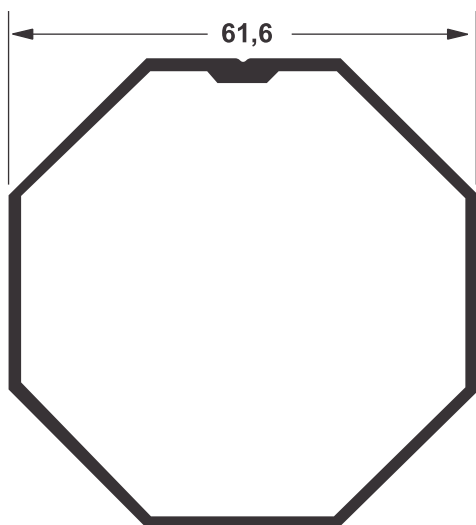

MN - 015
0,790 Kg/m

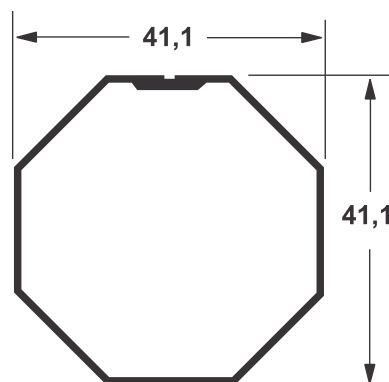

MD 238
0,489 Kg/m

LINHA INTEGRADA

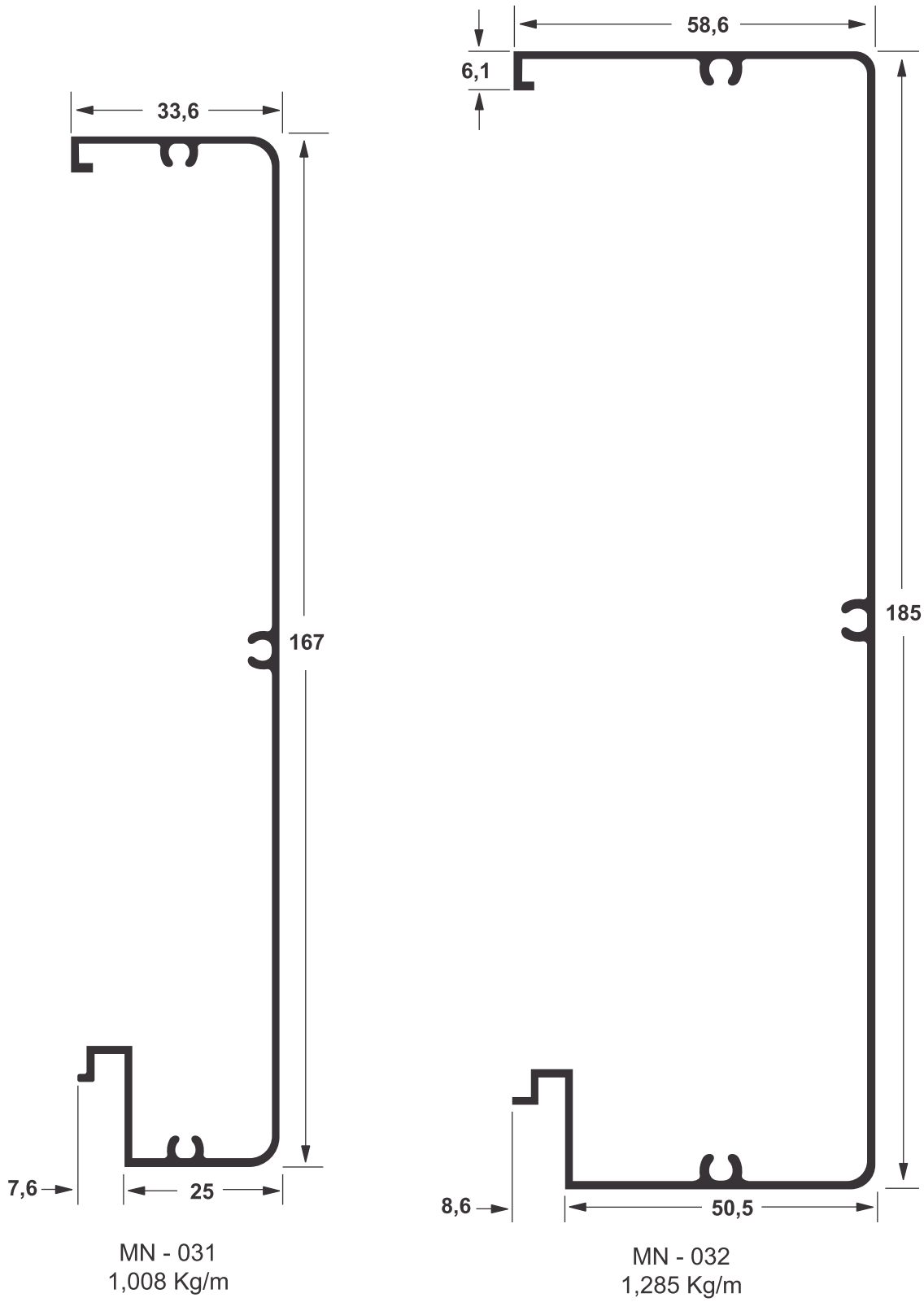

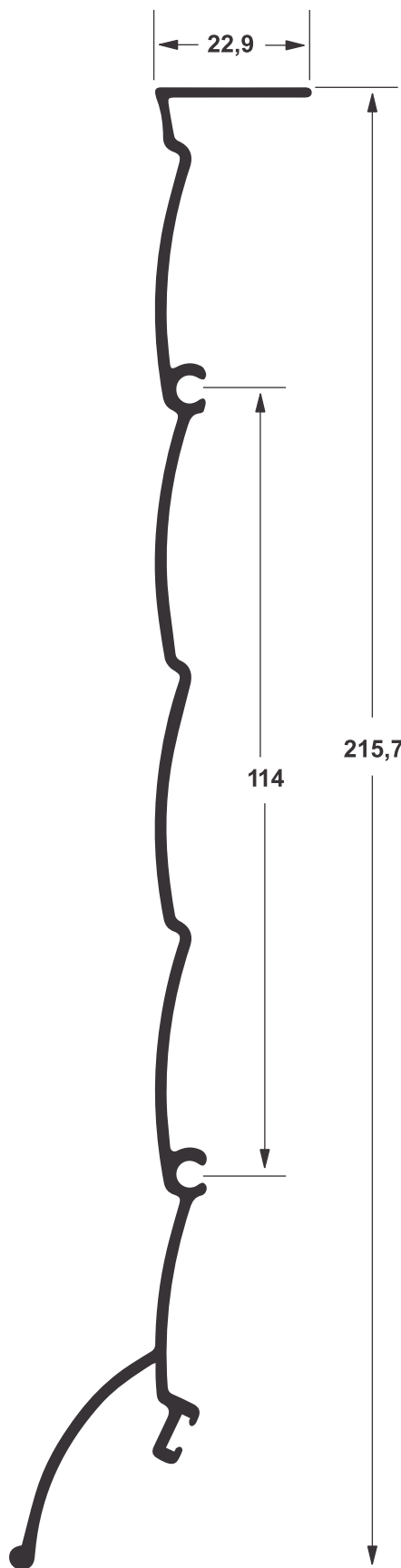

MN - 039
1,356 Kg/m

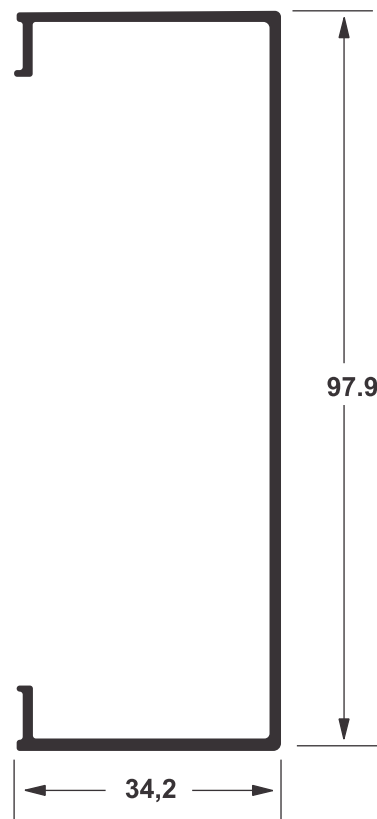

MN - 050
0,734 Kg/m

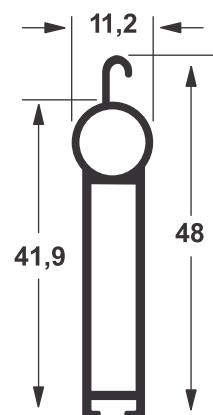

MN - 055
0,382 Kg/m

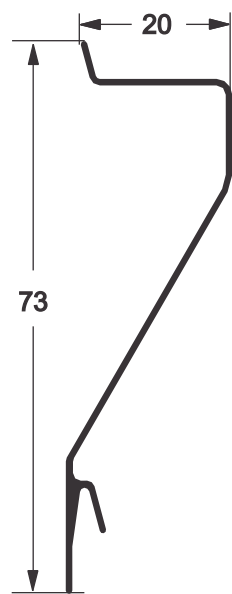

Z - 203
0,241 Kg/m

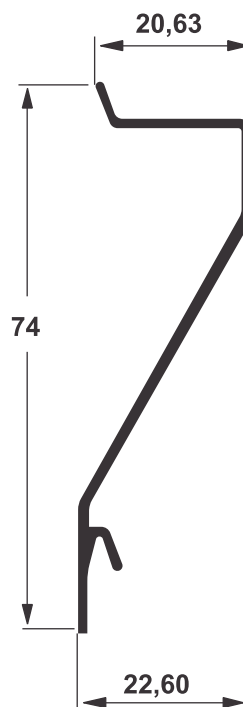

VZ - 006
0,300 Kg/m

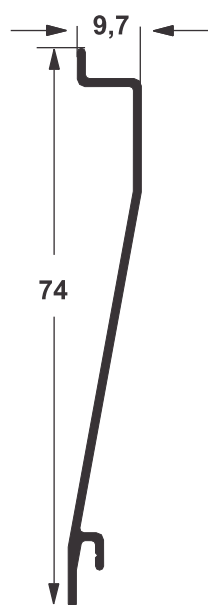

VZ - 024
0,299 Kg/m

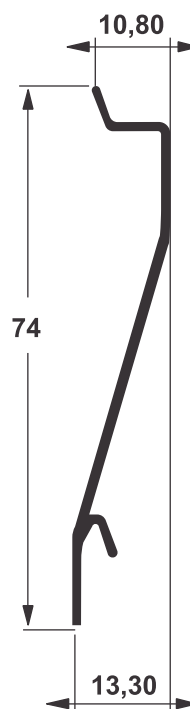

VZ - 051
0,260 Kg/m

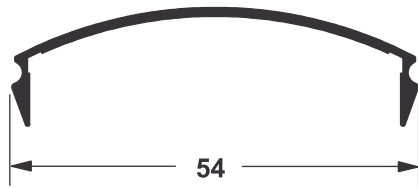

CG - 074
0,233 Kg/m

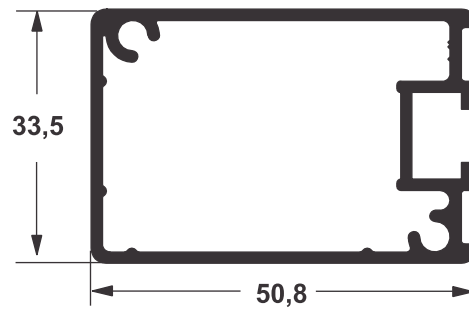

CG - 077
0,834 Kg/m

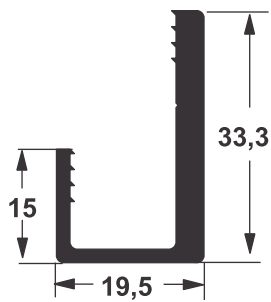

CG - 075
0,496 Kg/m

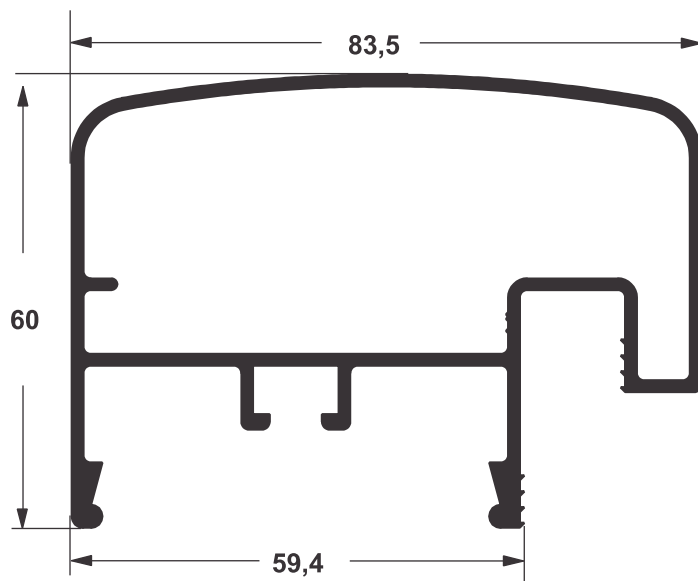

CG - 083
1,463 Kg/m

CORRIMÃO / GUARDA COPO

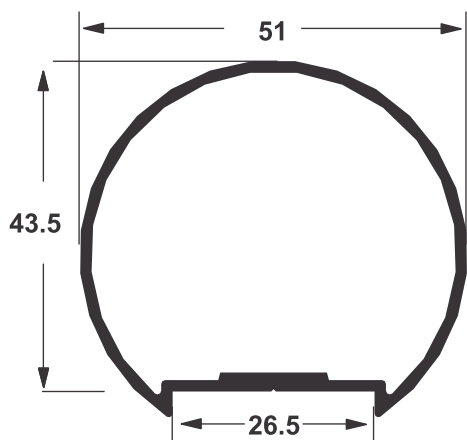

EX - 071
0,775 Kg/m

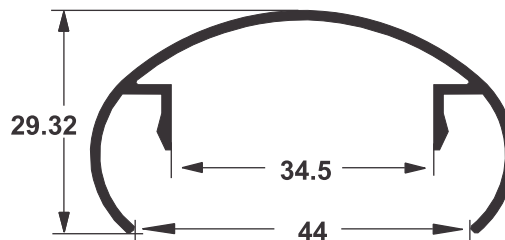

CG - 078
0,423 Kg/m

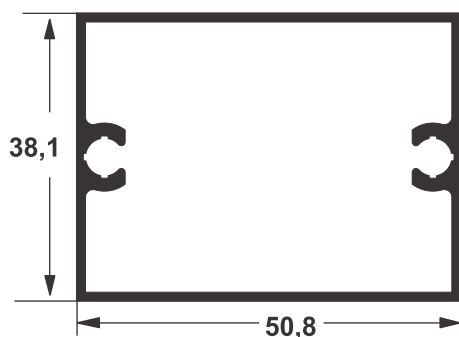

D - 103
0,722 Kg/m

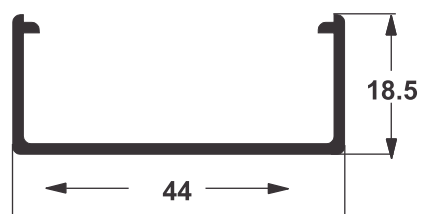

CG - 079
0,304 Kg/m

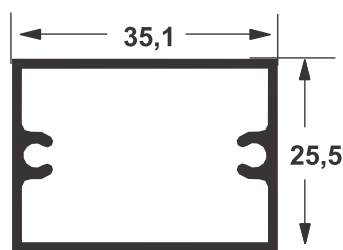

D - 055
0,467 Kg/m

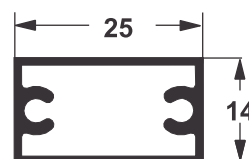

D - 082
0,328 Kg/m

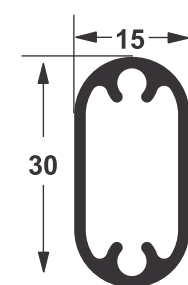

EX - 087
0,355 Kg/m

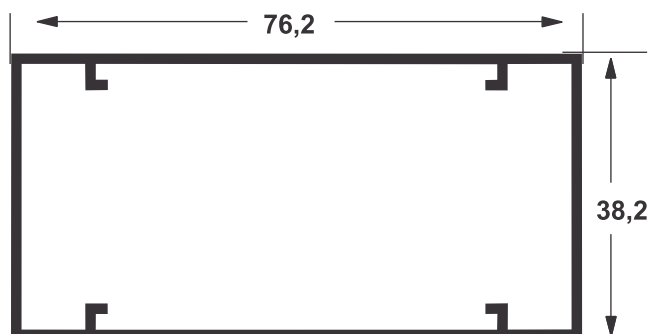

D - 069
0,952 Kg/m

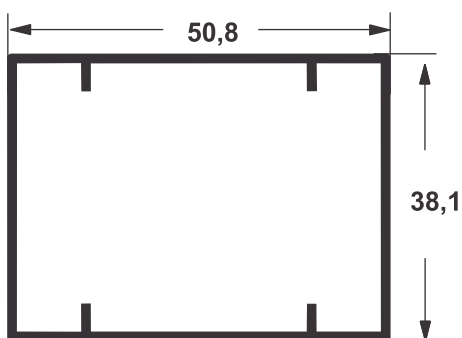

D - 078
0,622 Kg/m

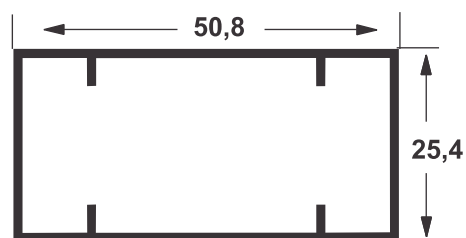

D - 079
0,523 Kg/m

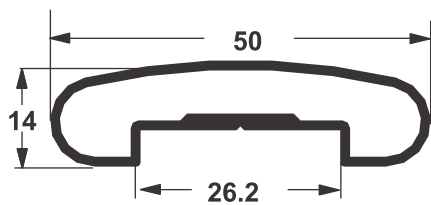

D - 095
0,434 Kg/m

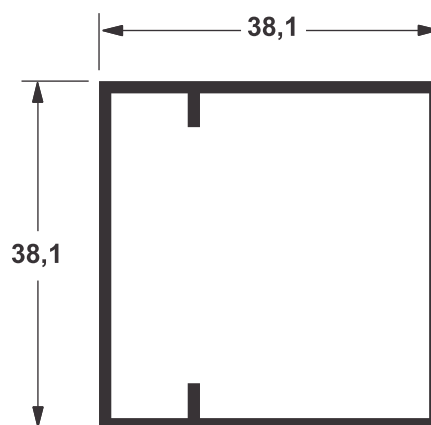

D - 102
0,627 Kg/m

PORTÕES

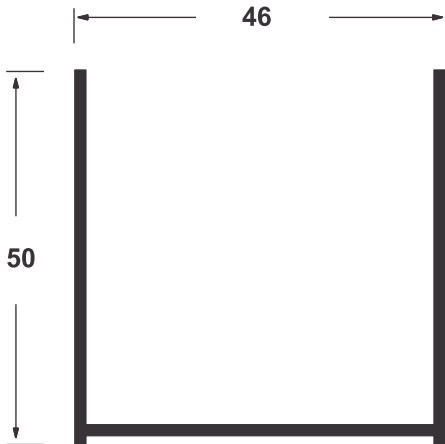

E - 362
0,541 Kg/m

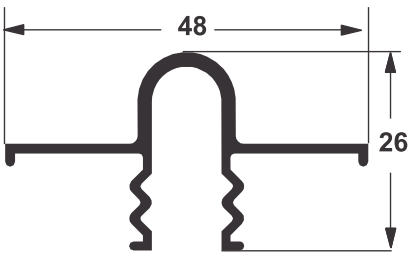

E - 364
0,411 Kg/m

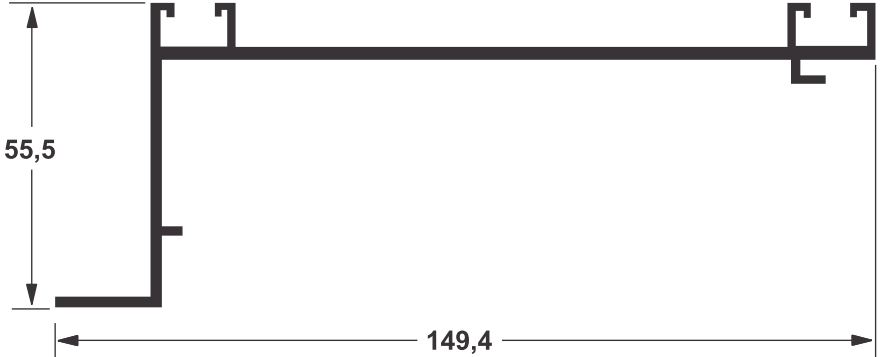

TP - 600
1,390 Kg/m

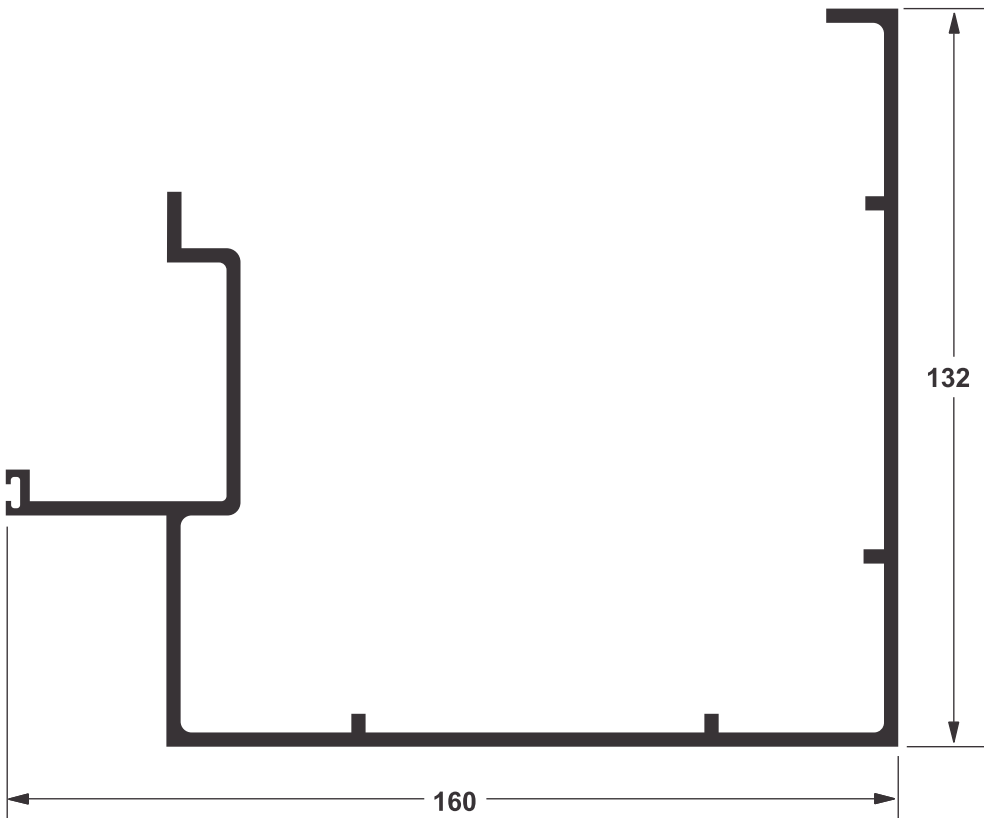

CX - 600
3,074Kg/m

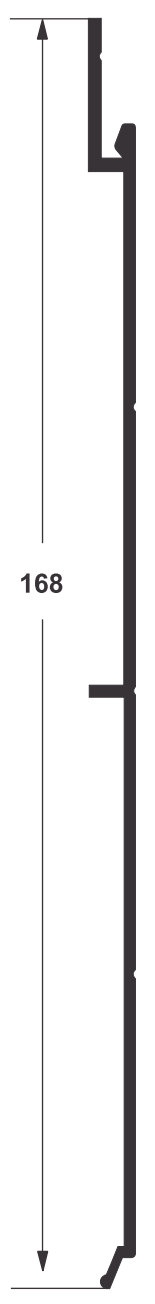

Y - 335
0,828 Kg/m

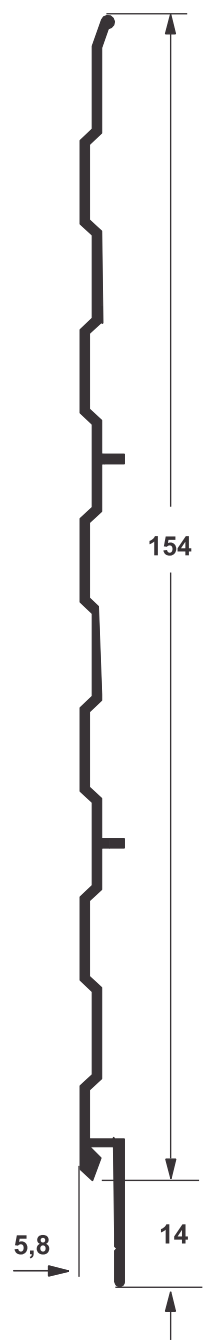

Y - 429
0,700 Kg/m

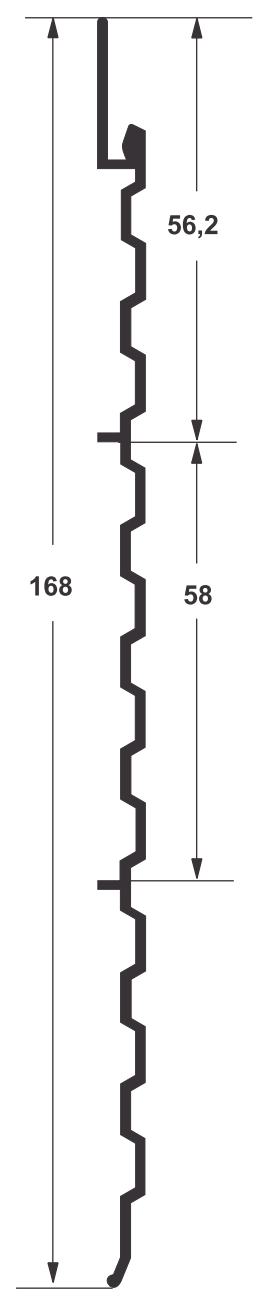

Y - 355
0,712Kg/m

LAMBRIL

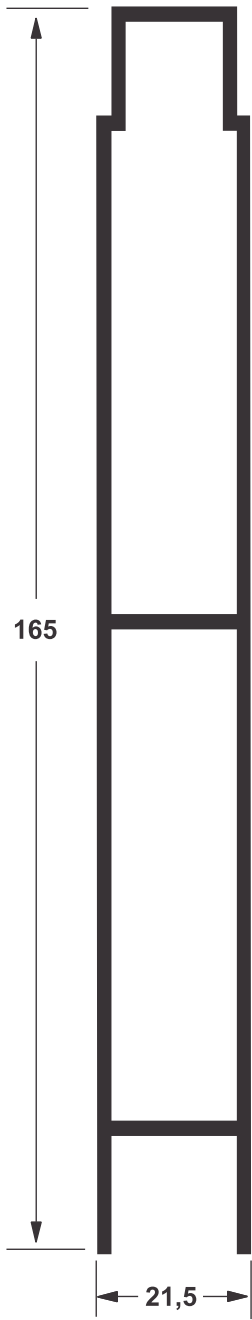

FAL - 1328
1.640 Kg/m

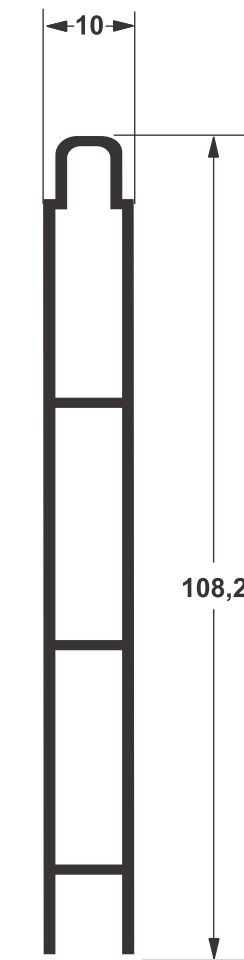

FAL - 220
0,685 kg/m

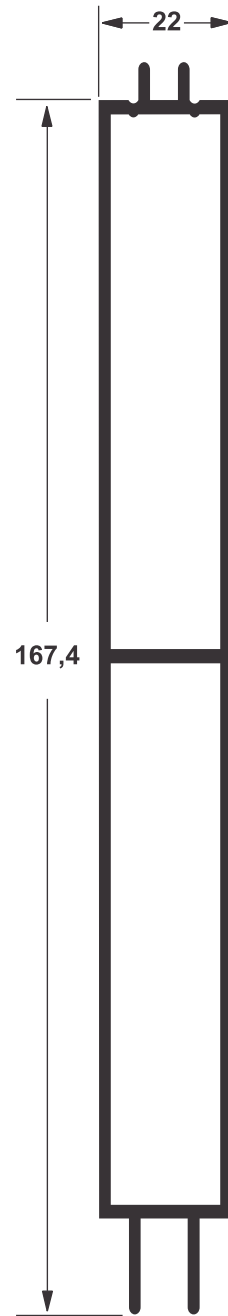

FAL - 1177
1,804 Kg/m

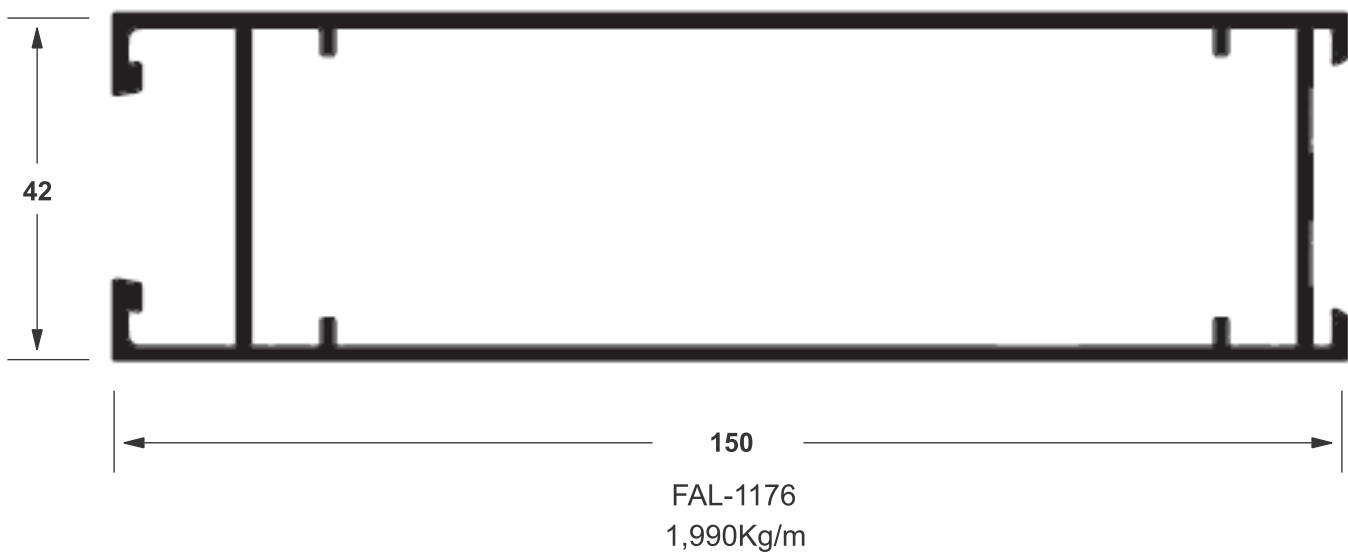
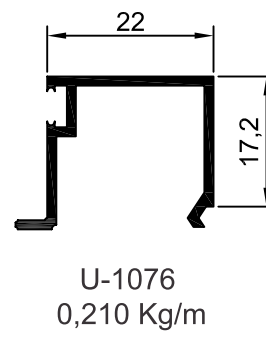
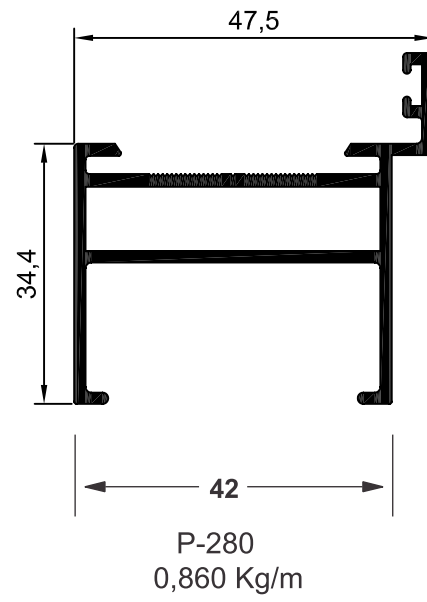
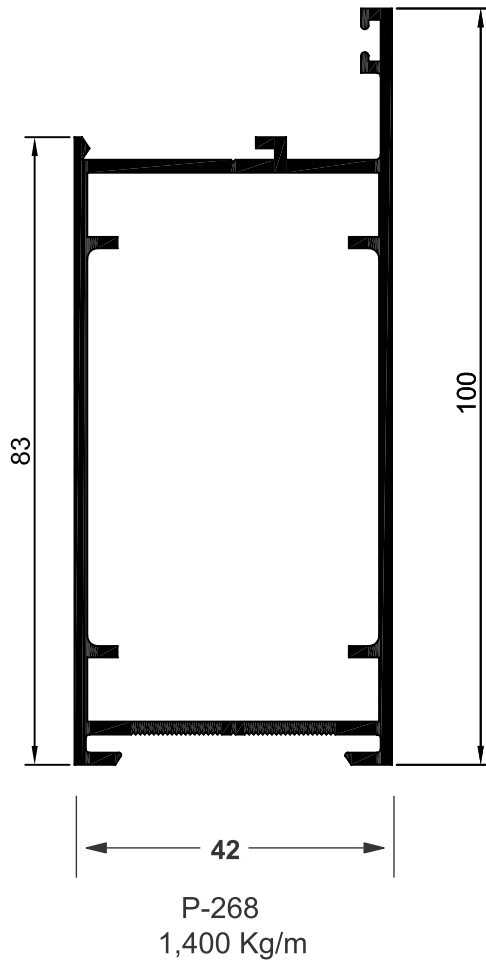

PERFIS DIVERSOS

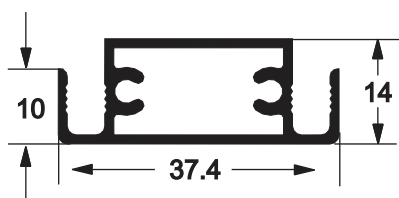

CX-001
0,410 Kg/m

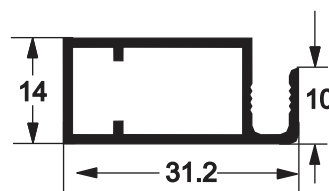

CX-002
0,290 Kg/m

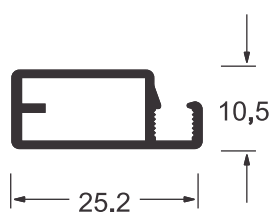

FAL-157
0,195 Kg/m

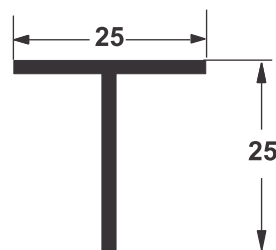

T-123
0,160 Kg/m

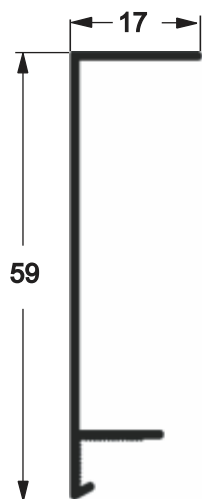

EX-015
0,235 Kg/m